



TENDER DOCUMENT

NEW MANGALORE PORT AUTHORITY

CIVIL ENGINEERING DEPARTMENT

NIT No. CIVIL/CE(C)/EE(C)/05/2023-24

E-Tender Event No.2023_NMPT_751486_1

Tender for

**“SUPPLY AND INSTALLATION OF FLAG MAST
NEAR ENTRANCE GATE AT NMPA”**

THROUGH E-TENDERING MODE

Tender Amount	:	Rs. 11,94,517/-
E.M.D.	:	Rs. 28,200/-
Tender Fee	:	Rs. 560/-(Including GST @ 12%)



TENDER DOCUMENT
NEW MANGALORE PORT AUTHORITY
CIVIL ENGINEERING DEPARTMENT

Tender for
"SUPPLY AND INSTALLATION OF FLAG MAST
NEAR ENTRANCE GATE AT NMPA"

Volume - 1

Table of Contents

i) NOTICE INVITING TENDER	9
ii) INSTRUCTIONS TO TENDERERS	12
A. Instructions for E-Tendering	12
B. Instructions to Tenderers (General).....	16
1. Introduction:	16
2. Applicants:	16
3. Invitation for Bids:.....	17
4. Purchase of Tender Documents:.....	17
5. One Bid per Bidder:	17
6. Cost of Bidding:	17
7. Site visit:	17
8. Content of Bidding Documents:	17
9. Clarification of the Bidding Documents:	18
10. Amendment of Bidding Documents:	18
11. Preparation of bids:	18
12. Minimum Eligibility Criteria:	18
13. Bid Prices:	20
14. Currencies of Bid and Payment:.....	20
15. Bid Validity:.....	20
16. Bid Security / EMD:	20
17. No Alternative Proposals by Bidders:	21
18. Format and Signing of Bid:	21
19. Bid Submission:	21
20. Deadline for Submission of the Bids:.....	23
21. Late Bids:	23
22. Modification and Withdrawal of Bids:.....	24
23. Bid Opening - Technical Bid:	24
24. Bid Opening – Financial Bid:	24
25. Clarification of Bids:.....	24
26. Examination of Bids and Determination of Responsiveness:.....	25
27. Correction of Errors: (Not Applicable).....	25

28.	Evaluation and Comparison of Bids:	25
29.	Alteration of tender documents:	25
30.	Alternative conditions and Proposal:	26
31.	Award of Contract:	26
32.	Notification of Award:.....	26
33.	Release of Bid Security / EMD:	26
34.	Performance Security:.....	26
35.	Fraud and Corrupt Practices:	27
36.	Rejection of Tender:.....	28
37.	Additional Information:.....	28
38.	Compliance of Local Content as per Make in India Policy:	28
	Annexure – 1	28
	Annexure – 2.....	30
	Annexure – 3.....	32
	Annexure – 4.....	33
	Annexure – 5.....	34
	Annexure – 6.....	35
	Annexure – 6A (Not applicable).....	36
	Annexure – 7	37
	Annexure – 8.....	38
	Annexure-9.....	40
	BID SECURITY (BANK GUARANTEE) (NOT APPLICABLE)	40
	Annexure-10	42
	Annexure-11	43
	Annexure 12.....	44
	Annexure-13	46
	SECTION - II.....	47
	iii) FORM OF AGREEMENT	47
	SECTION - III	49
	iv) CONDITIONS OF CONTRACT.....	49
	A. General.....	49
	1. Definitions.....	49

2.	Interpretation.....	51
3.	Language and Law	51
4.	Engineer or his nominee's Decisions	51
5.	Delegation.....	51
6.	Communications	51
7.	Contract Agreement	51
8.	Subcontracting	52
9.	Personnel.....	52
10.	Employer's and Contractor's Risks	52
11.	Employer's Risks	52
12.	Contractor's Risks	53
13.	Insurance	53
14.	Site Investigation Reports.....	54
15.	Queries about the Contract Data	54
16.	Contractor to Construct the Works.....	54
17.	The Works to Be Completed by the Intended Completion Date.....	54
18.	Approval by the Engineer or his nominee	54
19.	Safety	54
20.	Discoveries	54
21.	Possession of the Site.....	54
22.	Access to the Site	55
23.	Instructions.....	55
24.	Disputes	55
25.	Settlement of Disputes.....	55
26.	Replacement of conciliator (deleted)	56
B.	TIME CONTROL	57
27.	Program	57
28.	Revised Program	57
29.	Extension of the Intended Completion Date	57
30.	Delays Ordered by the Engineer or his nominee	57
31.	Management Meetings	58
32.	Early Warning.....	58

C.	QUALITY CONTROL.....	59
33.	Identify Defects	59
34.	Tests.....	59
35.	Defect Liability.....	59
36.	Uncorrected Defects.....	60
D.	COST CONTROL	61
37.	Bill of Quantities.....	61
38.	Changes in the Quantities.....	61
39.	Variations.....	61
40.	Payments for Variations	62
41.	Cash flow forecasts	62
42.	Payment Certificates	62
43.	Payments.....	64
44.	Compensation Events	64
45.	Tax.....	65
46.	Currencies.....	66
47.	Price Adjustment. (Not Applicable).....	66
48.	Retention	66
49.	Liquidated Damages.....	66
50.	Nominated Subcontractors	67
51.	Advance payment (Not Applicable).....	67
52.	Securities.....	67
53.	Removal of Craft or Plant which has sunk (not applicable to this contract).....	68
54.	Cost of Repairs.....	68
E.	FINISHING THE CONTRACT	68
55.	Completion	68
56.	Taking Over	69
57.	Final Account.....	70
58.	Submission of 'As built Drawings'	70
59.	Termination.....	70
60.	Payment upon Termination.....	71

61. Property	72
62. Release from Performance	72
F. SPECIAL CONDITIONS OF CONTRACT	72
63. Labour.....	72
64. Compliance with labour regulations	72
65. Safety, Security and Protection of the Environment	73
66. Insurance of Works and Contractor's Equipment	74
67. War Risks Insurance.....	75
68. Royalty	75
69. Transport of Contractor's Equipment or Temporary Works.....	75
70. Transport of Materials or Plant.....	75
71. Labor Laws & Regulations.....	75
72. Life Saving Appliances and First Aid.....	78
73. Diving Operations (Not Applicable).....	78
74. Bribes.....	78
75. Details to be Confidential	79
76. Contractor's Temporary works, office, etc.	79
77. Water Supply	79
78. Power Supply	80
79. Taxes and Duties.....	80
80. Price Adjustment (not applicable to this contract)	81
81. Noise and Disturbance	81
82. Safety Code	81
83. Port Authority Rules.....	82
84. Execution of work.....	82
85. Customs Duty	83
86. Drawings & Designs.....	84
87. Monsoon Period	85
88. Progress Report.....	85
89. Completion Documents (not applicable).....	86
90. Submission of statutory documents	87
G. SALIENT FEATURES OF SOME MAJOR LAWS APPLICABLE TO	

ESTABLISHMENTS ENGAGED IN CONSTRUCTION WORK.....

v) CONTRACT DATA90

vi) FORM OF SECURITIES94

Annexure A.....95

Annexure B (NA)97

Annexure – C (NA)99

APPENDIX 1 TO GENERAL CONDITIONS OF CONTRACT (NA)..... 101

NEW MANGALORE PORT AUTHORITY
PANAMBUR, MANGALORE -575010
CIVIL ENGINEERING DEPARTMENT
NIT No: CIVIL/CE(C)/EE(C)/05/2023-24 Date: 02-05-2023
TENDER ID: 2023_NMPT_751486_1

i) NOTICE INVITING TENDER

(Through E-Procurement only)

E-Tenders are invited by New Mangalore Port Authority, Panambur, Mangalore-575010 through <https://www.eprocure.gov.in/eprocure/app> of CPP portal from the Contractor fulfilling the Minimum Eligibility Criteria stipulated in this notice in two cover bidding procedure for the work of "Supply and Installation of flag mast near entrance gate at NMPA"

a) The tenderers must have experience of having successfully completed *similar works during last 7 (seven) years ending last day of month previous to the one in which applications are invited shall be either of the following:-

At least Three similar completed works costing not less than the amount equal to Rs.4.80 lakhs each

or

At least Two similar completed works costing not less than the amount equal to Rs.6.00 lakhs each

or

At least One similar completed work costing not less than the amount equal to Rs.9.60 lakhs

Note1:*Similar work(s) means Supply and Erection of High Mast Tower or Flag Mast.

Note2: Documentary evidence for successful completion of the work shall be furnished along with work order and work completion certificate.

b) Average Financial turnover of the tenderer over the last three financial years 2019-20, 2020-21 and 2021-22 shall be at least Rs.3.60 lakhs.

The financial capacity of bidders would be evaluated considering the works in hand at NMPA. The port would award the work not exceeding the remaining financial capacity of the bidder. The financial capacity to be 3.33times of the average financial turnover of last three years of the bidder minus works in hand at NMPA. The bidder must fill the Annexure-6.

In case the average turnover is Rs.3.00 crores, the financial capacity of the contractor will considered as (3x3.333) Rs.10.00crores.

The turnover means sales/ contract receipts excluding taxes other income shall not

be considered for calculation of turnover.

Pertinent information is given in the following table:

i)	Estimated Amount put to Tender	Rs.11,94,517/-
ii)	Earnest Money Deposit (EMD)	Rs.28,200/- (Rupees Twenty Eight Thousand Two Hundred Only.) The EMD shall be in the form of Insurance Surety Bonds, Account Payee Demand draft, Fixed Deposit Receipt, Bankers Cheque or shall be paid by RTGS in favour of F.A. & C.A.O., NMPA. Scanned copy should be uploaded along with bid. The benefit of Exemption of EMD to all Micro and small enterprises (MSE) will allowed. Shall upload with their offer, the proof of their being MSE registered with district industries center (DIC) or Khadhi and village industries commission or Khadhi and Industries board (KVIV) or Coir board or National Small Industries Corporation (NSIC) or Directorate of handicrafts and handlooms or Udyam Registration Certificate or any other body specified by Ministry of MSME.
iii)	Cost of Tender (Tender fee)	Rs. 560/- (Rupees Five Hundred Sixty Only) Payment of Tender fee by NEFT in favour of F.A. & C.A.O., NMPA. Scanned copy should be uploaded along with bid. The benefit of Exemption of Tender fee to Micro and small enterprises (MSE) will allowed. Shall upload with their offer, the proof of their being MSE registered with district industries center (DIC) or Khadhi and village industries commission or Khadhi and Industries board (KVIV) or Coir board or National Small Industries Corporation (NSIC) or Directorate of handicrafts and handlooms or Udyam Registration Certificate or any other body specified by Ministry of MSME.
iv)	Document download start date and time	02-05-2023 at 15.00 HRS
v)	Seek clarification start date and time	NA
vi)	Seek clarification end date and	NA

	time	
vii)	Bid submission start date and time	16-05-2023 at 10.00 HRS
vii)	Bid submission closing date and time	23-05-2023 at 15.00 HRS
ix)	Date & time of opening of Cover -I : Technical Part - II : Financial	24-05-2023at 15.30 HRS Shall be communicated separately.
x)	Completion period	3 (Three) Months (including monsoon)
xi)	Validity of Tender	120 days from the date of closing of online submission of e-tender.

Tenderer shall have to pay the prescribed cost of tender i.e., Rs.560/-(Rupees Five Hundred Sixty Only) by NEFT in favour of F.A. & C.A.O., NMPA.

NMPA Bank Details.

1. Name of the Bank: State Bank of India, Panambur, Mangalore - 575 010.
2. Bank A/C No. 10205649448
3. IFSC Code: SBIN0002249
4. MICR Code: 575002011

Contact Nos. 0824-2887306 and 0824-2407149

Email id: yogindra.s@nmpt.gov.in / chiefengineer@nmpt.gov.in

Amendments / further information etc. pertaining to the tender, if any shall be uploaded only on websites <https://www.eprocure.gov.in/eprocure/app> of CPP portal, may have to be referred by the prospective Tenderer from time to time.

-sd-

Executive Engineer (Civil)

NEW MANGALORE PORT AUTHORITY

PANAMBUR, MANGALORE -575010

NIT No: CIVIL/CE(C)/EE(C)/05/2023-24

E-Tender event No. 2023_NMPT_751486_1

ii) INSTRUCTIONS TO TENDERERS

A. Instructions for E-Tendering

INSTRUCTION TO E-TENDERING

1. SPECIAL INSTRUCTIONS TO THE BIDDERS FOR THE E-SUBMISSION OF THE BIDS ONLINE THROUGH THIS E-PROCUREMENT PORTAL

This is an e-procurement event of NMPA. The e-procurement service provider is <https://www.eprocure.gov.in/eprocure/app> of CPP portal. You are requested to read the terms & conditions of this tender before submitting your online tender. Tenderers who do not comply with the conditions with documentary proof (wherever required) will not qualify in the Tender.

1. Bidder should do Online Enrolment in the Portal using the option Click Here to Enroll available in the Home Page. Then the Digital Signature enrollment has to be done with the e-token, after logging into the portal.
2. Bidder then logs into the portal giving user id / password chosen during enrollment.
3. The e-token that is registered should be used by the bidder and should not be misused by others.
4. DSC once mapped to an account cannot be remapped to any other account. It can only be inactivated.
5. The Bidders can update well in advance, the documents such as certificates, purchase order details etc., under My Documents option and these can be selected as per tender requirements and then attached along with bid documents during bid submission. This will ensure lesser upload of bid documents.
6. After downloading / getting the tender schedules, the Bidder should go through them carefully and then submit the documents as per the tender document; otherwise, the bid will be rejected.
7. The BOQ template must not be modified/replaced by the bidder and the same should be uploaded after filling the relevant columns, else the bidder is liable to be rejected for that tender. Bidders are allowed to enter the Bidder Name and Values only.
8. If there are any clarifications, this may be obtained online through the e-Procurement Portal, or through the contact details given in the tender document. Bidder should take into account of the corrigendum published before submitting the

bids online on the portal or on www.newmangaloreport.gov.in

Bidder, in advance, should prepare the bid documents to be submitted as indicated in the tender schedule and they should be in PDF formats.

9. Bidder should arrange for the EMD and tender fee as specified in the tender. The benefit of Exemption of EMD to all Micro and small enterprises (MSE) will be allowed. Bidder shall upload with their offer, the proof of their being MSE registered with district industries center (DIC) or Khadi and village industries commission or Khadi and Industries board (KVIV) or Coir board or National Small Industries Corporation (NSIC) or Directorate of handicrafts and handlooms or Udyam Registration Certificate or any other body specified by Ministry of MSME will be considered. The bidder should read the terms and conditions and accept the same to proceed further to submit the bids.
10. The bidder has to submit the tender document(s) online well in advance before the prescribed time to avoid any delay or problem during the bid submission process.
11. There is no limit on the size of the file uploaded at the server end. However, the upload is decided on the Memory available at the Client System as well as the Network bandwidth available at the client side at that point of time. In order to reduce the file size, bidders are suggested to scan the documents in 75-100 DPI so that the clarity is maintained and the size of the file gets reduced. This will help in quick uploading even at very low bandwidth speeds.
12. It is important to note that, the bidder has to click on the Freeze Bid Button, to ensure that, he/she completes the Bid Submission Process. Bids, which are not frozen, are considered as Incomplete/Invalid bids and are not considered for evaluation purposes.
13. The Tender Inviting Authority (TIA) will not be held responsible for any sort of delay or the difficulties faced during the submission of bids online by the bidders due to local issues.
14. The bidder may submit the bid documents online mode only, through this portal. Offline documents will not be handled through this system.
15. At the time of freezing the bid, the e-Procurement system will give a successful bid updating message after uploading all the bid documents submitted and then a bid summary will be shown with the bid no., date & time of submission of the bid with all other relevant details. The documents submitted by the bidders will be digitally signed using the e-token of the bidder and then submitted.
16. After the bid submission, the bid summary has to be printed and kept as an acknowledgement as a token of the submission of the bid. The bid

summary will act as a proof of bid submission for a tender floated and will also act as an entry point to participate in the bid opening event.

17. Successful bid submission from the system means, the bids as uploaded by the bidder is received and stored in the system. System does not certify for its correctness.
18. The bidder should see that the bid documents submitted should be free from virus and if the documents could not be opened, due to virus, during tender opening, the bid is liable to be rejected.
19. The time that is displayed from the server clock at the top of the tender Portal, will be valid for all actions of requesting bid submission, bid opening etc., in the e-Procurement portal. The Time followed in this portal is as per Indian Standard Time (IST) which is GMT+5:30. The bidders should adhere to this time during bid submission.
20. The bidders are requested to submit the bids through online e-Procurement system to the Tender Inviting Authority (TIA) well before the bid submission end date and time (as per Server System Clock).
21. Tender form Fee and EMD shall be submitted with the Part I- Technical BID. BID submitted without fees, as mentioned above will not be considered for evaluation and shall be rejected summarily the benefit of Exemption of EMD and tender fee to all Micro and small enterprises (MSE) registered with district industries center (DIC) or Khadhi and village industries commission or Khadhi and Industries board (KVIV) or Coir board or National Small Industries Corporation (NSIC) or Directorate of handicrafts and handlooms or any other body specified by Ministry of MSME, will be considered. The bidder shall upload with their offer, the proof of their being MSE.
22. The bidder/tenderer/contractor shall file the applicable returns with Tax departments in time and submit the same as documentary proof. The GST applicable shall be shown as a separate line items in the Tax invoices to avail in put credit to Port.

2. Cover - I Details (Technical)

The following documents shall be uploaded online only.

1. Scanned copy of NEFT Payment details for cost of tender / documentary evidence for exemption of tender fee.
2. Scanned copy of RTGS/NEFT Payment details for EMD/ documentary evidence for exemption of EMD.
3. Scanned copy of documents as per Annexure 1 to 13 of section I(iii) of volume-I (Original power of attorney i.e. Annexure 2 to be submitted by post or by hand

immediately after the closing date for submission of online e-tender).

4. Scanned copy of valid PAN card, ESI, PF and GST Registration certificate.
5. List of Ongoing works in hand at NMPA should be indicated in the prescribed form.
6. Scanned copy of Form of Tender as per Section VI(iii) of volume -III
7. Technical bid document – Cover I (Volume I to Volume III) along with amendments and clarifications.

3. Cover – II Detail (Finance)

PRICE BID (Bill of Quantities)

Price should be quoted in the BOQ template available in the portal. The BOQ template must not be modified/replaced by the bidder and the same should be uploaded after filling the relevant columns, else the bidder is liable to be rejected for that tender. Bidders are allowed to enter the Bidder Name and Values only.

Any indication of 'Quoted price' in the online technical bid documents shall lead to rejection of the bid outright.

The price bid submitted through e-portal mode only will be taken up for the purpose for evaluation.

4. Opening of bids

- A. Part I Techno-Commercial bid will be opened electronically on specified date and time as given in the NIT. Bidder(s) can witness electronic opening of bid.
- B. Part II Price bid will be opened electronically of only those bidder(s) whose Part I Techno-Commercial Bid is found to be Techno-Commercially acceptable by NMPA. Such bidder(s) will be intimated, the date of opening of Part II Price bid, through valid email confirmed by them.

Note: The tenderers are advised to offer their best possible rates. There would generally be no negotiations hence most competitive prices may be quoted while submitting the price bid. However in case the lowest rate appears to be reasonable taking into account the prevailing market conditions, the work may be awarded to the lowest bidder and if the rate is still considered high, action as per prevailing instructions / guidelines shall be taken. All entries in the tender should be entered in online Technical & Commercial Formats without any ambiguity.

5. Evaluation process:

A proposal shall be considered responsive if –

- a. It is received by the proposed Due Date and Time.
- b. It is Digitally Signed.
- c. It contains the information and documents as required in the Tender Document.
- d. It contains information in formats specified in the Tender Document.
- e. It mentions the validity period as set out in the document.

- f. It provides the information in reasonable detail. The Port Authority reserves the right to determine whether the information has been provided in reasonable detail.
- g. There are no significant inconsistencies between the proposal and the supporting documents.
- h. The Technical qualification conforms to as specified in the qualification criteria.
- i. A Tender that is substantially responsive is one that conforms to the preceding requirements without material deviation or reservation. A material deviation or reservation is one (1) which affects in any substantial way, the scope, quality, or performance of the Tenderer or (2) which limits in any substantial way, inconsistent with the Tender document, or (3) whose rectification would affect unfairly the competitive position of other Qualified Applicant presenting substantially responsive bids.
- j. The Port Authority reserves the right to reject any tender which in its opinion is non-responsive and no request for alteration, modification, substitution or withdrawal shall be entertained by the Port Authority in respect of such Tenders.
- k. The Port Authority would have the right to review the Technical Qualification and seek clarifications wherever necessary.
- l. Since the tender involves selection based on pre-qualification criteria and technical specification, the Chief Engineer will examine and seek clarification if any and list out the firms, which are found technically suitable and Cover-II Price Bid of such tenderers only will be opened and EMD will be returned to the unsuccessful tenderers
- m. The date and time will be intimated to tenderers whose offers are found suitable and Cover – II of such tenderers will be opened on the specified date and time
- n. The cost of stamping Agreement must be borne by the successful Tenderer
- o. The Fax/E-Mail offers will be treated as defective, invalid and rejected. Only detailed complete offers received through online prior to closing time and date of the tenders will be taken as valid.

B. Instructions to Tenderers (General)

1. Introduction:

This work essentially comprises of "Supply and Installation of flag mast near entrance gate at NMPA"

2. Applicants:

Contractors who wish to bid for the tender for the contract work should apply for the tender document. The successful bidder will be expected to complete the works by

the intended completion date specified in the Contract document.

3. Invitation for Bids:

The online Invitation for Bids is open to all eligible bidders meeting the eligibility criteria. The bidders may submit bids for the works detailed in the NIT through e-tender mode only.

4. Purchase of Tender Documents:

Tender document can be downloaded from NMPA website www.newmangaloreport.gov.in, www.tender.gov.in & <https://www.eprocure.gov.in/eprocure/app> of CPP portal

5. One Bid per Bidder:

Each bidder shall submit only one bid for one package. Bidder who submits or participates in more than one Bid will cause all the proposals with the Bidder’s participation to be disqualified.

6. Cost of Bidding:

The bidder shall bear all costs associated with the preparation and submission of his Bid, and the Employer will in no case be responsible and liable for those costs.

7. Site visit:

The Bidder, at the Bidder’s own responsibility and risk is encouraged to visit and examine the work site and its surroundings and obtain all information that may be necessary for preparing the Bid and entering into a contract for construction of the Works. The costs of visiting the site shall be at the Bidders’ own expense.

8. Content of Bidding Documents:

Tender Document will consist of:

Volume I	Section I	Notice Inviting Tenders Instructions to Tenderers Annexure (1 to 13)
	Section II	Form of Agreement
	Section III	Conditions of Contract: Part A - E: General Conditions Conditions of Contract : Part F: Special Conditions Contract Data Form of Securities (A & B) Appendix – I and Appendix - II
Volume II	Section IV	Technical Specifications
	Section V	Drawings

Volume III	Section VI	Preamble
		Bill of Quantities
		For of tender
	Section VII	Schedules (A & B)

Any indication of "Quoted price" in the technical bid, shall lead to rejection of the bid outright. For evaluation purpose the uploaded offer documents will be treated as authentic and final. No hard copy shall be submitted, upload the entire document on the CPP portal only.

9. Clarification of the Bidding Documents:

The Tenderers are advised to examine the Tender Document carefully and if there be or appear to be any ambiguity or discrepancy in the documents, or any clarifications needed on the Tender Documents; these shall be referred to the Chief Engineer (Civil) in writing, so as to reach at least three days before start date of submission of bid. It is to be noted that queries asked after due date will not be answered. Employer's clarifications shall be furnished in the CPP e-portal or shall be issued a corrigendum in the web site after closing date of online pre-bid meeting without identifying the source.

A provision is made in the CPP e-portal for online pre-bid meeting during the date mentioned in the NIT. The bidders can ask queries if any during the period of pre-bid meeting through online. The queries of the bidders shall be answered online or a separate consolidated list of queries and clarifications shall be uploaded in web sites after closing date of online pre-bid meeting.

10. Amendment of Bidding Documents:

Any modification of the tender documents as a result of any ambiguity shall be shall be made exclusively through the issue of an Addendum. Any addendum thus issued shall be part of the tender documents and will be uploaded in CPP e-portal and Port website to all the bidders. Prospective

Bidders shall acknowledge receipt of each addendum to the Employer. Such addenda will be numbered and it shall be submitted by the Tenderers as part of Part I of their bid. The Addendum can also be downloaded from NMPA official website from 'Ongoing Project link'. The responsibility of downloading such addendum / amendment from NMPA website and CPP e-portal fully lies with the bidder.

11. Preparation of bids:

All documents relating to the bid shall be in the English language.

12. Minimum Eligibility Criteria:

a) The tenderers must have experience of having successfully completed *similar works

during last 7 (seven) years ending last day of month previous to the one in which applications are invited shall be either of the following:-

At least Three similar completed works costing not less than the amount equal to Rs.4.80 lakhs each

or

At least Two similar completed works costing not less than the amount equal to Rs.6.00 lakhs each

or

At least One similar completed work costing not less than the amount equal to Rs.9.60 lakhs

Note1:*Similar work(s) means Supply and Erection of High Mast Tower or Flag Mast.

Note2: Documentary evidence for successful completion of the work shall be furnished along with work order and work completion certificate

- b) Average Financial turnover of the tenderer over the last three financial years 2019-20, 2020-21 and 2021-22 shall be at least Rs.3.60 lakhs.

The financial capacity of bidders would be evaluated considering the works in hand at NMPA. The port would award the work not exceeding the remaining financial capacity of the bidder. The financial capacity to be 3.33 times of the average financial turnover of last three years of the bidder minus works in hand at NMPA. The bidder must fill the Annexure-6.

In case the average turnover is Rs.3.00 crores, the financial capacity of the contractor will be considered as (3x3.333) Rs.10.00 crores.

The turnover means sales / contract receipts excluding taxes other income shall not be considered for calculation of turnover.

Copy of the work order, Client's satisfactory work completion Certificate, along with any other documentary proof certifying the year of completion, brief description of the project and project completion cost shall be submitted in support of the assignments performed and claimed by the tenderer to fulfill the eligibility criteria for qualification Experience of the tenderer / contractor for completed works, executed in private organization shall be considered only if the Tax Deduct the Source Certificate with respect to referred work, issued by Competent Authority is enclosed by the tenderer along with the tender

A statement duly certified by the Chartered accountant showing the average annual Financial Turnover over the last 3 financial years shall be submitted.

Even though the bidders meet the above qualifying criteria, they are subject to be disqualified if they have:

- i) made misleading or false representations in the forms, statements and attachments submitted in proof of the qualification requirements; and/or
- ii) record of poor performance such as abandoning the works, not properly completing the contract, inordinate delays in completion, litigation history, or financial failures etc.,

13. Bid Prices:

The contract shall be for the whole works as described in based on the priced Bill of Quantities submitted through CPP e-portal by the Bidder .The Bidder shall fill in the percentage of Excess or Less in the Bill of Quantities through CPP e-portal. Items for which no rate or price is entered will not be paid for by the Employer when executed and shall be deemed covered by the other rates and prices in the Bill of Quantities.

14. Currencies of Bid and Payment:

The Unit rates and the prices shall be quoted by the bidder entirely in Indian Rupees

15. Bid Validity:

Bids shall remain valid for a period not less than one hundred twenty days (120 days) after the last date for online bid submission. A bid valid for a shorter period shall be rejected by the Employer as non-responsive.

In exceptional circumstances, prior to expiry of the original bid validity period, the Employer may request that the bidders may extend the period of validity for a specified additional period. The request and the bidders' responses shall be made in writing or by cable. A bidder agreeing to the request will not be permitted to modify his bid and also shall submit an extension for EMD, if it is in the form of Bank Guarantee

16. Bid Security / EMD:

- i. The EMD shall be in the form of Insurance Surety Bonds, Account Payee Demand draft, Fixed Deposit Receipt, Bankers Cheque or shall be paid by RTGS/NEFT in favour of Financial Adviser & Chief Accounts Officer, New Mangalore Port Authority, Mangalore
 - 1. Name of the Bank: State Bank of India, Panambur, Mangalore - 10.
 - 2. Bank A/C No. 10205649448
 - 3. IFSC Code: SBIN0002249
 - 4. MICR Code: 575002011
- ii. The Techno Commercial Bid shall be accompanied by the RTGS/NEFT deposit details towards Earnest Money Deposit of Rs.28200/- (Rupees TwentyEight Thousand Two Hundred Only) as stipulated in the tender. The tender without EMD shall be treated invalid. The benefit of Exemption of EMD and tender fee to all Micro and small enterprises (MSE) registered with district industries center (DIC) or Khadhi and village industries commission or Khadhi and Industries board (KVIV) or Coir board or National Small Industries Corporation (NSIC) or Directorate of

- handicrafts and handlooms or any other body specified by Ministry of MSME, will be considered. The bidder shall upload with their offer, the proof of their being MSE.
- iii. In the event of Bidder withdrawing his Bid before the expiry of tender validity period of 120 days from the last date for online bid submission, the tender shall be cancelled and EMD shall be forfeited.
 - iv. The Earnest Money Deposit of unsuccessful bidder shall be returned without interest as early as possible by RTGS/NEFT on conclusion of contract. The Earnest Money Deposit of the successful bidder shall be refunded (without interest) after he has signed the agreement and furnished required performance security.
 - v. The Bid Security of a successful bidder will be forfeited in the following cases:
 - a) If the bidder withdraws his Tender during the period of bid validity.
 - b) In case of a successful tenderer fails
 - i) to commence the work, apart forfeiture of other claims
 - ii) within the specified time limit to sign the Agreement or furnish the required Performance Security. In the event of forfeiting the EMD / SD / LD and while imposing penalty GST as applicable will be collected.

17. No Alternative Proposals by Bidders:

Bidders shall submit offers that comply with the requirements of the bidding documents, including the basic technical design as indicated in the drawing and specifications. Alternatives will not be considered.

18. Format and Signing of Bid:

The Bid shall be in online mode. The Bid shall contain no alterations or additions, except those comply with instructions issued by the Employer

19. Bid Submission:

Tender document including quoted bid price have to be submitted online only through CPP Portal before deadline for online submission of bid.

For evaluation purpose the uploaded offer documents will be treated as authentic and final. Any documents submitted in the form of hard copy except Power of attorney.

The Tender shall be submitted in Two Bids.

- I. Technical Bid: Shall contain the following.
 - i) Techno Commercial Bid: Shall contain all the documents. Techno Commercial Bid should not contain Price Bid. "Disclosure/indication of Price in the Techno Commercial Bid shall render the tender disqualified and rejected.
 - ii) The details of payment of EARNEST MONEY DEPOSIT for Rs.28200/- (Rupees TwentyEight Thousand Two Hundred Only) by RTGS/NEFT to NMPA Bank Account, failing which the Techno commercial Bid shall not be considered).
 - iii) Transaction details of payment towards the COST OF TENDER Fee: Rs. 560/- (Rupees Five Hundred Sixty Only) (To be paid by RTGS/NEFT to NMPA Bank Account).

- II. FINANCIAL BID: shall contain only the Price.
- III. LAST DATE FOR SUBMISSION OF ONLINE TENDER: is as per the date mentioned in the NIT
- NMPA may at its sole discretion reserves the right to extend the date for receipt of Bid. Bid after the aforesaid time and date or the extended time and date, if any, shall not be accepted by the portal.
- The following details pertaining to Techno Commercial Bid shall be uploaded online.
- a) Letter of Submission- Covering letter (vide Annexure – 1)
 - b) Power of Attorney in favour of signatory/s to the Tender,(vide Annexure -2) (Original power of attorney i.e. Annexur-2 to be submitted by post or by hand so as to reach the Executive Engineer (Civil) immediately after the closing date for submission of online e-tender).
 - c) Organization Details (vide Annexure-3)
 - d) Details of “Minimum eligibility criteria” as per Clause 12 of instruction to Tenderers and certificates (Client Certificates / work completion certificates or any other documentary evidences with respect to the eligibility work) (vide Annexure-4) of condition of contract. The following specific instruction may be noted ;
 - i) Bidders are expected to provide information in respect of Eligible Assignments in this Section. The assignments cited must comply with the criteria specified in Clause No. 12 (a) for “Minimum eligibility”.
 - ii) A separate sheet should be filled for each of the eligible assignments the details are to be supplemented by documentary proof from the respective client for having carried out such assignment duly certified by client’s completion certificates and work orders etc.
 - iii) The works indicated in Annexure- 4 will only be considered for evaluation. Mere submission of work completion certificate will not be considered as Eligible Assignments
 - e) A statement duly certified by Chartered Accountant showing Average Financial turnover of the tenderer over the last three financial years (vide Annexure-5) with balance sheet.
 - f) List of Ongoing works in hand at NMPA should be indicated in the prescribed form (Annexure-6)
 - g) A list of Plant and equipment proposed to be engaged for work. (vide Annexure-7) The equipment indicated in the Annexure -7 will form part of contract agreement and as such the bidders are requested to indicate the availability of the equipment at site at what stage of the construction period the equipment would made available.
 - h) Tenderer should submit copy of Permanent Account Number. (PAN), ESI, PF and GST Registration (GSTIN) Number along with certificates issued by the authority as applicable.
 - i) A declaration to the effect that (vide Annexure -8):-
 - a. All details regarding construction plant and machinery, temporary work and

personnel for site organization considered necessary and sufficient for the work have been furnished in the Annexure to Conditions of Contract in Volume I and that such plant, temporary works and personnel for site organization will be available at appropriate time of relevant works for which the equipment have been proposed at site till the completion of the respective work.

- b. No conditions are incorporated in the financial bid. In case any conditions are specified in the financial bid, the tender will be rejected summarily without making any further reference to the bidder.
- c. We have not made any payment or illegal gratification to any persons/ authority connected with the bid process so as to influence the bid process and have not committed any offence under PC Act in connection with the bid.
- d. We disclose with that we have made / not made payments or propose to be made to any intermediaries (agents) etc., in connection with the bid.
- j) NEFT Payment details towards cost of tender / documentary evidence for exemption of tender cost.
- k) RTGS/NEFT Payment details towards EMD / documentary evidence for exemption of EMD

20. Deadline for Submission of the Bids:

- i. The completed bid shall be submitted in the electronic form by the date and time mentioned in NIT only through CPP e-portal.
- ii. The Employer may extend the deadline for submission of bids by issuing an amendment in accordance with Clause 10, in which case all rights and obligations of the Employer and the bidders previously subject to the original deadline will thereafter be subject to the deadline as extended.
- iii. Price should be quoted in CPP e-portal. Any indication of 'Quoted price' in the online technical bid documents shall lead to rejection of the bid outright. For evaluation purpose the uploaded offer documents will be treated as authentic and final. No hard copy shall be submitted for reference purpose. The bid submitted through e-tendering mode only will be taken up for the purpose for evaluation.
- iv. The uploaded Port Tender Document will be treated as authentic tender and if any discrepancy is noticed at any stage between the Port's tender document and the one submitted/uploaded by the tenderer, the conditions mentioned in the Port's uploaded document shall prevail. Besides, the tenderer shall be liable for legal action for the lapses.

21. Late Bids:

The time that is displayed from the server clock at the top of the CPP e-portal, will be valid for all actions of requesting bid submission, bid opening etc., The bidders should adhere to this time during bid submission.

22. Modification and Withdrawal of Bids:

- i. Bidders may modify the offers by deleting their already freezed bids in online only through CPP e-portal (after submission of bid) and resubmit/upload the revised offer before the deadline prescribed in Clause 20.
- ii. No bid shall be withdrawn and resubmitted through CPP e-portal by the bidder after the deadline for submission of bids.
- iii. Withdrawal of a Bid between the deadline for submission of bids and the expiration of the original period of bid validity specified in Clause 15 may result in the forfeiture of the Bid Security or the bidder shall be disqualified from bidding for any contract with New Mangalore Port Authority for a period of 2 (two) years in pursuant to Clause 16.
- iv. Bidders may only modify the prices and other required details of their Bids by Resubmitting Bid only in accordance with this clause through CPP e-portal.

23. Bid Opening - Technical Bid:

- a. On the due date and time as specified in Clause 20, the Employer will first open Techno Commercial bids of all bids received online in presence of the Bidders or their representatives who choose to attend. In the event of specified date for bid opening is declared as holiday by the Employer, the bid will be opened at the appointed time and location on the next working day.
- b. In the first instance the Techno Commercial Bid containing the RTGS/NEFT payment details of EMD & Cost of tender document will be verified. If EMD and Tender Fee is in line with the Tender Condition there after the Techno Commercial Bid will be considered for evaluation.
- c. If all Bidders have submitted unconditional Bids together with requisite Bid security, then all Bidders will be so informed then and there. If any Bid contains any deviation from the Bids documents and / or if the same does not contains Bid security in the manner prescribed in the Bid documents, then that Bid will be rejected and the Bidder informed accordingly.

24. Bid Opening – Financial Bid:

The date and time of opening of price bid (cover-II) shall be intimated to the qualified bidders based on the evaluation of the technical bid. The price bid (cover-II) of such eligible bidders shall be opened on the specified date and time.

If bidder withdraws his tender after opening of price bid the bidder will be disqualified for participating in NMPA tender for a period of two years.

25. Clarification of Bids:

To assist in the examination and comparison of Bids, the Employer may, at his discretion, ask any Bidder for clarification of his Bid, including breakdown of unit rates. The request for clarification and the response shall be in writing, but no change in the price or substance of the Bid shall be sought, offered, or permitted.

No Bidder shall contact the Employer on any matter relating to his bid from the time

of the bid opening to the time the contract is awarded. If the Bidder wishes to bring additional information to the notice of the Employer, he should do so in writing.

Any effort by the Bidder to influence the Employer's bid evaluation, bid comparison or contract award decisions, may result in the rejection of his bid.

Employer reserves the right to reject any Bid, if the Bidder does not provide the clarification sought for by the Employer, within the time specified by the Employer, for proper evaluation of the Bid.

26. Examination of Bids and Determination of Responsiveness:

Prior to detailed evaluation of Bids, NMPA will determine whether each Bid

- a) meets the eligibility criteria as defined in Clause 12.
- b) has been properly signed by an authorised signatory (accredited representative) holding Power of Attorney in his favour. The Power of Attorney shall interalia include a provision to bind the Bidder to settlement of disputes clause;
- c) is accompanied by the requisite Bid security and;
- d) is responsive to the requirements of the Bidding documents.

A responsive Bid is one which conforms to all the terms, conditions and specification of the Bidding documents, without material deviation or reservation. A material deviation or reservation is one

- a) which affects in any substantial way the scope, quality or performance of the Works;
- b) which limits in any substantial way, the Employer's rights or the Bidder's obligations under the Contract; or
- c) whose rectification would affect unfairly the competitive position of other Bidders presenting responsive Bids.

The tenderer shall submit a certificate in the tender schedule in the Technical Bid that he has not incorporated any conditions in the Financial Bid and in case any conditions are specified in the financial bid his tender will be rejected without making any further reference to him.

If a Bid is not substantially responsive, it shall be rejected by the Employer, and may not subsequently be made responsive by correction or withdrawal of the non-conforming deviation or reservation.

27. Correction of Errors: (Not Applicable)

28. Evaluation and Comparison of Bids:

The Employer will evaluate and compare only the Bids determined to be responsive in accordance with Clause 26. In evaluating the Bids, the Employer will determine for each Bid the evaluated Bid Price by adjusting the Bid Price as follows:

- a) making appropriate adjustments to reflect discounts or other price modifications offered in accordance with Clause 22.

29. Alteration of tender documents:

No alteration shall be made in any of the tender documents or in the Bill of Quantities and the tender shall comply strictly with the terms and conditions of the

tender document. The Employer may however ask any tenderer for clarifications of his tender if required. Nevertheless, no tenderer will be permitted to alter his tender price after opening of the tender.

30. Alternative conditions and Proposal:

The Tenderer shall note that alternative or qualifying tender conditions, or alternative design proposal for whole or part of the work will not be acceptable. Tenders containing any qualifying conditions or even Bidder's clarifications in any form will be treated as non-responsive and will run the risk of rejection. Part II: Price Bid of such Bidder's will not be opened.

31. Award of Contract:

The Employer will award the Contract to the bidder whose bid has been determined to be responsive to the bidding documents and who has offered the lowest evaluated bid price, provided that such bidder has been determined to be

- a) Eligible in accordance with the provisions of Clause 12, and
- b) Qualified in accordance with the provisions of Clause 12.

32. Notification of Award:

- i) The Bidder whose Bid has been accepted will be notified about the award by the Employer prior to expiration of the Bid validity period by, fax or e-mail and confirmed by registered letter. This letter (hereinafter and in the Conditions of Contract called the "Letter of Acceptance") will state the sum that the Employer will pay the Contractor in consideration of the execution, completion and maintenance of the works by the Contractor as prescribed by the Contract (hereinafter and in the Contract called the "Contract Price").
- ii) The notification of award will constitute the formation of the Contract subject only to the furnishing of a performance security in accordance with the provisions of Clause 34.
- iii) The Agreement will also incorporate all correspondence exchanged between the employer and the successful bidder. Within 21 days of receipt of Letter of Acceptance, the successful bidder shall furnish the performance security and sign the Agreement with the Employer. The contractor shall make 12 copies of the Agreement and submit to the employer within 7 days following the date of signing of Agreement.

33. Release of Bid Security / EMD:

The Earnest Money Deposit of unsuccessful bidder, shall be returned without interest by RTGS/NEFT on conclusion of Contract. The Earnest Money Deposit of the successful bidder if deposited in cash, shall be refunded (without interest) after he has signed the agreement and furnished required performance security.

34. Performance Security:

- i) Within 21 days of receipt of the Letter of Acceptance, the successful Bidder shall deliver to the Employer a Performance Security in the form in the form of Insurance Surety Bonds, Account Payee Demand draft, Fixed Deposit Receipt from a

- commercial bank, remittance by RTGS for an amount equivalent to 5% of the Contract price including GST, as applicable rounded off to the nearest 1000.
- ii) If the performance security is provided by the successful Bidder in the form of a Bank Guarantee, it shall be issued by a Nationalized /Scheduled Indian bank having its branch at Mangalore acceptable by NMPA. The BG shall be issued in favor of New Mangalore Port Authority in the Format enclosed in Volume I as Annexure-A.

35. Fraud and Corrupt Practices:

The bidder and their respective officers, employees, agents and advisers shall observe the highest standard of ethics during the Selection Process. Notwithstanding anything to the contrary contained in this document, the Port shall reject the tender without being liable in any manner whatsoever to the bidder, if it determines that the bidder has, directly or indirectly or through an agent, engaged in corrupt practice, fraudulent practice, coercive practice, undesirable practice or restrictive practice (collectively the "Prohibited Practices") in the Selection Process. In such an event, the Port shall, without prejudice to its any other rights or remedies, forfeit and appropriate the Bid Security or Performance Security, as the case may be, as mutually agreed genuine pre-estimated compensation and damages payable to the Port for, inter alia, time, cost and effort of the Authority, in regard to the Tender, including consideration and evaluation of such Bidder's Proposal. Such Bidder shall not be eligible to participate in any tender or RFP issued by the Authority during a period of 2 (two) years from the date such Bidder is found by the Authority to have directly or through an agent, engaged or indulged in any corrupt practice, fraudulent practice, coercive practice, undesirable practice or restrictive practice, as the case may be.

For the purposes of this Clause, the following terms shall have the meaning hereinafter respectively assigned to them:

- (a) "corrupt practice" means
- i) the offering, giving, receiving, or soliciting, directly or indirectly, of anything of value to influence the action of any person connected with the Selection Process (for avoidance of doubt, offering of employment to or employing or engaging in any manner whatsoever, directly or indirectly, any official of the Authority who is or has been associated in any manner, directly or indirectly with the Selection Process or the LOA or has dealt with matters concerning the Agreement or arising there from, before or after the execution thereof, at any time prior to the expiry of one year from the date such official resigns or retires from or otherwise ceases to be in the service of the Authority, shall be deemed to constitute influencing the actions of a person connected with the Selection Process; or
- ii) engaging in any manner whatsoever, whether during the Selection Process or after the issue of the LOA or after the execution of the Agreement, as the case may be, any person in respect of any matter relating to the Project or the LOA or the Agreement, who at any time has been or is a legal, financial or technical consultant/ adviser of

- the Authority in relation to any matter concerning the Project;
- (b) "fraudulent practice" means a misrepresentation or omission of facts or disclosure of incomplete facts, in order to influence the Selection Process;
 - (c) "coercive practice" means impairing or harming or threatening to impair or harm, directly or indirectly, any persons or property to influence any person's participation or action in the Selection Process;
 - (d) "undesirable practice" means
 - i) establishing contact with any person connected with or employed or engaged by the Authority with the objective of canvassing, lobbying or in any manner influencing or attempting to influence the Selection Process; or
 - ii) having a Conflict of Interest; and
 - (e) "Restrictive practice" means forming a cartel or arriving at any understanding or arrangement among Applicants with the objective of restricting or manipulating a full and fair competition in the Selection Process.

36. Rejection of Tender:

Any Tender not conforming to the foregoing instructions will not be considered. The Employer does not bind himself to accept the lowest or any tender and has the right to reject any tender without assigning any reason thereof. No representation whatsoever will be entertained on this account.

37. Additional Information:

The "Instructions to Tenderers" shall not form part of the Contract. They are intended only to aid the Tenderers in the preparation of their tender.

38. Compliance of Local Content as per Make in India Policy:

Bidder shall comply with DPIIT Order No. P-45021/2/2017-PP(B-II) dtd. 16-09-2020 in respect of Local Content and furnish an undertaking in the prescribed format as per Annexure 13, to that effect, failing which, the bid may be liable for cancellation.

LETTER OF SUBMISSION - COVERING LETTER
(ON THE LETTER HEAD OF THE BIDDER)

Date:

To,

The Executive Engineer (Civil),
New Mangalore Port Authority,
Administration Building,
Panambur, Mangalore – 575 010

Sir,

Sub: The work of "Supply and Installation of flag mast near entrance gate at NMPA"

Being duly authorized to represent and act on behalf of
(Hereinafter referred to as "the Bidder") and having reviewed and fully understood all of the requirements of the bid document and information provided, the undersigned hereby apply for the project referred above.

We are submitting our Bid enclosing the following, with the details as per the requirements of the Bid Document, for your evaluation.

- i. Tender Document along with Addendum No ----,
- ii. Power of Attorney - (Annexure - 2)
- iii. Organization Details - (Annexure - 3)
- iv. Details to fulfill the "Minimum Eligibility Criteria" and certificates – (Annexure 4)
- v. Average Financial turnover over the last three financial year - (Annexure 5)
- vi. list of ongoing works In hand at NMPA-(Annexure-6)
- vii. List of plant and equipment – (Annexure - 7)
- viii. Declaration – (Annexure – 8)
- ix. EMD Paid by RTGS/NEFT vide UTR No.....dtd. of (name and address of the branch).
- x. Banker's Details – Annexure 10 & 11
- xi. Tender fee paid by NEFT vide vide UTR No.....dtd. of (name and address of the branch).
- xii. Copy of valid PAN Card ESI, PF and GST Registration certificate.

Signature

(Authorised Signatory)

ON STAMP PAPER of Rs 100/-
"SUPPLY AND INSTALLATION OF FLAG MAST NEAR ENTRANCE GATE AT
NMPA"

FORMAT OF POWER OF ATTORNEY (in original)

In favour of signatory/s to the Tender, duly authenticated by Notary Public.

POWER OF ATTORNEY IN FAVOUR OF -----
(Name, Designation, Company name)

TO ALL TO WHOM THESE PRESENTS shall come, I, (Name & address of the authorized person to sub-delegate/delegate powers, delegated on him by the Board of Directors) do hereby sub-delegate/delegate, in terms of the powers delegated to me by the Board of Directors, ----- (name of the Co.) to Shri ----- (name, designation & address of the Attorney) the following:

NOW KNOW YE AND THOSE PRESENTS that I, (Name & address of the authorized person to sub-delegate/delegate powers, delegated on him by the Board of Directors), do hereby authorize and empower Shri ----- (name, designation & address of the Attorney) to do severally amongst others, for the purpose of carrying on our business, the following:

- a) To represent lawfully the (name of the Co.) for obtaining bid/tender documents, prepare, sign, execute and submit tenders for execution of (Name of work) or any other works incidental to such construction works.
- b) To discuss the technical and financial matters, negotiate and accept prices and take decisions regarding terms and conditions and sign agreements and contracts and also to bind the (name of the Co.) to the arbitration clause included in the contract.
- c) For all or any of the purposes here of to sign and deliver or otherwise execute such deed or deeds, transfer or transfers, endorsement or endorsements and to perform such other acts, matters, things as the Attorney shall consider requisite or advisable as full and effectively as the Company could do, if present and acting there.

I, (Name & address of the authorized person to sub-delegate/delegate powers, delegated on him by the Board of Directors) in terms of the powers delegated to me by the Board of Directors of (name of the Co.), do hereby agree that all acts, deeds and things done by the said Attorney by virtue of this power of attorney, shall be construed as acts, deeds and things done by the Company.

I, (Name & address of the authorized person to sub-delegate/delegate powers, delegated on him by the Board of Directors), further undertake to ratify and confirm whatever our said attorney shall do or cause to be done for the Company, the said Company, in the premises, by virtue of the powers hereby given.

WHEREAS, this sub-delegation is signed and delivered to Shri ----- (name & designation of the Attorney), on this ____ day of _____, 20__ (Two thousand _____).

WHEREAS, even though this sub-delegation is signed on this ____ day of _____ 20____ (Two thousand _____), will have effect from the date he signs and receives this delegation.

IN WITNESS WHEREOF, I, (Name & address of the authorized person to sub-delegate/delegate powers, delegated on him by the Board of Directors) has, this ____ day of ____ 20____ (Two thousand _____) set my hands and subscribed my signature unto this instrument.

SIGNED AND DELIVERED ON
_____ BY

(Name of authorized person to delegate powers)

WITNESS:

SIGNED AND RECEIVED ON
_____ BY

(Name & designation of Attorney)

Annexure – 3**“SUPPLY AND INSTALLATION OF FLAG MAST NEAR ENTRANCE GATE AT
NMPA”**

--

ORGANIZATION DETAILS

CONTACT No.:

NAME OF APPLICANT:

1. Name of the Owner:
2. Address:
Telephone No. :
Fax No.
3. Description of Applicant
(for e.g. General, Civil Engineering
Contract or Joint Venture/Consortium etc.)
4. Registration and Classification of Contractors:
5. Name and address of bankers:
6. Number of years of experience as a general contractor:-
In own Country:
Internationally:
7. Number of years of experience as a sub-contractor:
Name and Address of partners or associated companies to be involved in the project
and whether Parent/Subsidiary/other:
8. Name and address of any associates knowledgeable in the procedures of customs,
immigration and local experience in various aspect of the project etc.
9. Name and address of the companies / Sub-contractors who will be involved in the
execution of works, namely:

Signature
(Authorised Signatory)

Annexure - 4

NEW MANGALORE PORT AUTHORITY

"SUPPLY AND INSTALLATION OF FLAG MAST NEAR ENTRANCE GATE AT
NMPA"

Tenderer shall furnish Details of "eligibility works experience" as per Clause 12(a) of Minimum Eligible Criteria (MEC) of Instruction to Tenderer and certificates in the following format (Client Certificates/work completion certificates or any other documentary evidences with respect to the eligibility work)

ELIGIBLE ASSIGNMENT DETAILS FOR MEC

Assignment Number:

Description	Bidder to fill up the details here
Name and Address of the Client	
Title of the Eligible Assignment	
Date of completion of the Eligible Assignment	
Project Cost	
Reference No of the enclosed work order	
Reference No of the enclosed Client work Completion Certificate	
Reference No of any other documentary evidence; if enclosed.	
Name, telephone no, telefax no and email address of the client's representative	
Description and Scope of Work	

Instructions:

- i. Bidders are expected to provide information in respect of Eligible Assignments in this Section. The assignments cited must comply with the criteria specified Clause No. 12.0(a) Minimum eligibility of the "Instructions to Tenderers".
- ii. A separate sheet should be filled for each of the eligible assignments.
- iii. The details are to be supplemented by documentary proof (Work order and work completion certificate) from the respective client for having carried out such assignment duly certified by clients.
- iv. The works indicated in this Annexure - 4 will be only being considered for evaluation. Mere submission of work completion certificate will not be considered as Eligible Assignments.

Signature
(Authorised Signatory)

Annexure - 5
NEW MANGALORE PORT AUTHORITY
"SUPPLY AND INSTALLATION OF FLAG MAST NEAR ENTRANCE GATE AT
NMPA"
FINANCIAL CAPABILITY

(A) Net worth & Average Annual Turnover of the Bidder

Net Worth	Turnover			
Year 1	Year 1	Year 2	Year 3	Average

Instructions:

Net Worth = (Subscribed and Paid-up Equity + Reserves) - (Revaluation reserves + Miscellaneous expenditure not written off + depreciation not provided for). Year 1 will be the Financial Year 2020-21. Year 2 shall be the year immediately preceding Year 1 and Year 3 shall be the year immediately preceding Year 2. The Bidder shall provide audited Annual Reports as required under this Bid Document.

Net worth & Annual turnover of the bidder shall be submitted duly verified by Chartered Accountant or Competent Authority.

(B) (Here specify proposed sources of credit line to meet the Cash flow demand for the work)

Source of Credit line	Amount

There should be a letter from the Bank mentioning that line of credit offered is specifically for this work/contract.

NOTE: If the Tenderer intends to meet the "Cash Flow Demand" for the project through their internal resources without availing the loan of credit, a specific mention to be made to this effect and proof for such resources shall be enclosed.

Certified by C.A Signature
 (Authorised Signatory)

Annexure - 6**NEW MANGALORE PORT AUTHORITY
"SUPPLY AND INSTALLATION OF FLAG MAST NEAR ENTRANCE GATE AT
NMPA"**LIST OF ONGOING WORKS IN HAND AT NMPA

The Tenderer shall furnish in the format given below details of works being carried out by him at the time of bidding in NMPA.

Sl. No.	Name of work	Work order No. and Date	Value Of Work Order In Rs.	Average annual financial turnover as per MEC for the work

Contractor

Annexure – 6A (Not applicable)

NEW MANGALORE PORT AUTHORITY
“SUPPLY AND INSTALLATION OF FLAG MAST NEAR ENTRANCE GATE AT
NMPA”

DETAILS OF PROPOSED APPROACH & METHODOLOGY

Bidder shall furnish a detailed method statement (Technical Note) for carrying out of the works, along with a construction programme showing sequence of operation and the time frame for various segments of temporary and permanent works.

Signature
(Authorised Signatory)

Annexure - 7

NEW MANGALORE PORT AUTHORITY
 "SUPPLY AND INSTALLATION OF FLAG MAST NEAR ENTRANCE GATE AT
 NMPA"

--

PLANT AND EQUIPMENT PROPOSED FOR THE WORK

Please indicate the main plant and equipment considered to be necessary for undertaking the work and whether this plant is ready in ownership or will be purchased or hired.

Description of equipment	Requirement no. / capacity	Owned / leased / to be procured	Nos / capacity	Age / condition	Remarks (from whom to be purchased)	At what stage of contract period the equipment will be available

Note: The equipment indicated in the above statement will form part of contract agreement and as such the bidders are requested to indicate the availability of the equipment at site and at what stage of the construction period in a separate column.

Signature
(Authorised Signatory)

Annexure - 8
NEW MANGALORE PORT AUTHORITY
"SUPPLY AND INSTALLATION OF FLAG MAST NEAR ENTRANCE GATE AT
NMPA"

DECLARATION

We M/s. (Name & address of the bidder) hereby declare that:-

- i. I have read the tender document Vol. I (Section I to III) Vol.II (Section IV and V) and Vol.III (Section V and VII) and agreed to the terms and conditions mentioned therein.
- ii. All details regarding construction plant, temporary work and personnel for site organisation considered necessary and sufficient for the work have been furnished in the Annexures to Conditions of Contract in Volume I and that such plant, temporary works and personnel for site organisation will be available at the site till the completion of the respective work.
- iii. No conditions are incorporated in the financial bid. In case any conditions are specified in the financial bid, the tender will be rejected summarily without making any further reference to the bidder.
- iv. We have not made any payment or illegal gratification to any persons/ authority connected with the bid process so as to influence the bid process and have not committed any offence under PC Act in connection with the bid.
- v. We shall undertake that, the Employer i.e. NMPA is indemnified against all damages or compensation payable at Law in respect of or in consequence of any accident or injury to any workman or other person in the employment of the Contractor or Sub-Contractor against all claims, demands, proceedings, costs, charges and expenses whatsoever in respect thereof or in relation thereto and the Employer shall be at liberty to deduct or adjust from the Contractor's bills an amount that Employer may be called upon to pay towards claims, demands, proceedings, costs, charges and expenses whatsoever in respect of or in relation to any accident or injury referred to above without any reference to the Contractor. The contractor shall execute indemnity bond in the prescribed format as per **Annexure - 12**
- vi. We shall comply with all the Central State and Municipal Laws and Rules and we shall be solely responsible for complying with the provisions of the Contract Labour (Regulations & Abolition) Act, 1970 & the contract labour (Regulation & Abolition) Karnataka Rules 1974 and rules there under and the enactments that may be applicable including ESI Act, the payment of wages act, Provident Fund Act, the

Minimum Wages Act, the Factory's Act. The Workmen Compensation Act or any other applicable legislation and the Municipal by-laws or other statutory Rules and Regulations whatsoever in force if these are applicable. Any obligations finding or otherwise missed under any statutory enactments, rules & regulations there under shall be the responsibility of the Contractor and the NMPA will take no responsibility for the same. The Contractor should take Workmen's Compensation Policy for his Workers, who are not covered under ESI and submit the same to the EIC immediately after commencement of the work

- vii. We undertake that, we are liable to pay all Statutory Compensation to the Labourers/persons engaged by him for the satisfactory execution of the works. If any claim is made against New Mangalore Port Authority on this work, the Port Authority shall have the right to deduct the same from the bill amount payable to the contractor after verification of the validity and if admissible as per rules
- viii. *We disclose with that we have made / not made payments or propose to be made to any intermediaries (agents) etc. in connection with the bid.

* Note: Delete whichever is not applicable.

Signature
(Authorised Signatory)

Annexure-9
BID SECURITY (BANK GUARANTEE) (NOT APPLICABLE)

WHEREAS, _____ [Name of Bidder] (hereinafter called "the Bidder") has submitted his bid dated _____ [date] for the Supply and Installation of flag mast near entrance gate at NMPA(hereinafter called "the Bid").

KNOW ALL PEOPLE by these presents that We _____ [name of bank] of _____ (name of country) having our registered office at _____ (hereinafter called "the Bank") are bound unto _____ [name of Employer] (hereinafter called "the Employer") in the sum of _____ 1 for which payment well and truly to be made to the said Employer the Bank binds itself, his successors and assigns by these presents.

SEALED with the Common Seal of the said Bank this _____ day of _____ 20 ____

THE CONDITIONS of these obligations are:

- (1) If after Bid opening the Bidder withdraws his Bid during the period of bid validity specified in the Form of Bid;
- or
- (2) If the Bidder having been notified of the acceptance of his Bid by the Employer during the period of bid validity:
 - (a) fails or refuses to execute the Form of Agreement in accordance with the Instructions to Bidders, if required; or
 - (b) fails or refuses to furnish the Performance Security, in accordance with the Instructions to Bidders, or
 - (c) does not accept the correction of the Bid Price pursuant to Clause 27;

We undertake to pay to the Employer up to the above amount upon receipt of his first written demand, without the Employer having to substantiate his demand, provided that in his demand the Employer will note that the amount claimed by him is due to him owing to the occurrence of one or any of the three conditions, specifying the occurred condition or conditions.

This Guarantee will remain in force up to and including the date _____ 2 days after the deadline for submission of Bids as such deadline is stated in the Instructions to Bidders or as it may be extended by the Employer, notice of which extension(s) to the Bank is hereby waived. Any demand in respect of this Guarantee should reach the Bank not later than the above date.

Notwithstanding anything mentioned above,

Our liability against this guarantee is restricted to Rs (Rupees only) and unless a claim in writing is lodged with us within 3 months of the date of expiry or the extended date of expiry of this guarantee all our liabilities under this guarantee shall stand discharges.

IN WITNESS WHEREOF this guarantee has been duly executed on this day of 20

DATE_____ SIGNATURE OF THE BANK_____

WITNESS_____ SEAL_____

[Signature, name and address]

The Bidder should insert the amount of the guarantee in words and figures denominated in Indian Rupees. This figure should be the same as shown in Clause 16 of the Instructions to Bidders.

30 days after the end of the validity period of the Bid. Date should be inserted by the Employer before the Bidding documents are issued.

Annexure-10

DETAILS OF THE PARTY OPTING FOR REFUND OF EMD THROUGH E-PAYMENT SYSTEM FROM NEW MANGALORE PORT AUTHORITY

Name of the Party :

Bank A/c No :

Account type : (Savings / Current / Overdraft)

Bank Name :

Branch :

IFSC Code Number : (11 digit code)

Centre (Location) :

FAX No. :

E-Mail ID : (For forwarding information of remittance)

Mobile No :

Signature of the Party

Annexure-11

FORMAT FOR FURNISHING BANK INFORMATION FOR e-PAYMENT

1	Name and full address of the beneficiary	
2	Credit Account No. (Should be full 14 digit)	
3	Account Type (SB or CA or OD)	
4	Name of the Bank	
5	Branch (Full address with telephone No.)	
6	IFSC Code Number (11 digit)	
7	MICR code (Should be 9 digit)	
8	Telephone/Mobile/Fax No. of the beneficiary	Telephone:
		Mobile :
		Fax :
9	Photostat copy of a Cheque	

Signature of the party with seal

Verified the details furnished by the party and it is ascertained that the information furnished are in full shape as required. Xerox copy of a Cheque is also enclosed.

Signature of the HOD/HOO with seal

Annexure 12**INDEMNITY BOND**

(To be furnished in Stamp paper not less than Rs.100 e-Stamp paper)

This deed of indemnity is executed by herein after referred to as 'Indemnifier' which expression shall unless repugnant to the context or meaning thereof, include its successors, Administrator, representatives and assignees in favour of New Mangalore Port Authority, Panambur, Mangalore 575010, herein after referred to as 'Indemnified' which expression shall unless repugnant to the context or meaning thereof include its representatives and assignees witnesses as to.

Whereas the indemnified herein as awarded to the indemnifier herein a Tender/Contract or for supply of / Construction of on terms and conditions set out interalia in the work order No..... valued at Rs.....

AND Whereas, the clauses No..... of the above mentioned work order provides for indemnifying the indemnified by the indemnifier for any accident, damage or compensation payable to any workmen or other person in the employment of the contractor or any sub-contractor during the period of tender/contract.

AND Whereas, the Indemnifier hereby irrevocably agrees to indemnify the indemnified against all damages or compensation payable at law in respect of or in consequence of any accident or injury to any workmen or other person in the employment of the contractor or sub-contractor against all claims, demands, proceedings, costs, charges and expenses whatsoever in respect thereof or in relation thereto and the indemnified shall be at liberty to deduct or adjust from the bills payable to the indemnifier by the indemnified for an amount that the indemnified may be called upon to pay towards claims, demands, proceedings, costs, charges and expenses whatsoever in respect of or in relation to any accident or injury referred to above without any reference to the indemnifier.

The Indemnifier shall comply with all the Central State and Municipal Laws and Rules and shall be solely responsible for complying with the provisions of the Contract Labour (Regulations & Abolition) Act, 1970 & the contract labour (Regulation & Abolition) Karnataka Rules 1974 and rules there under and the enactments that may be applicable including ESI Act, the payment of wages act, Provident Fund Act, the Minimum Wages Act, the Factory's Act, the Workmen Compensation Act or any other applicable legislation and the Municipal by-laws or other statutory Rules and Regulations whatsoever in force if these are applicable.

Any obligations finding or otherwise missed under any statutory enactments rules & regulations there under shall be the responsibility of the Indemnifier and the Indemnified will have no responsibility for the same. The Indemnifier shall obtain Workmen’s Compensation Policy for his workers, who are not covered under ESI and submit the same to the ESIC immediately after commencement of the work.

The Indemnifier is liable to pay all Statutory Compensation to the Labourers / persons engaged by him for the satisfactory execution of the works. If any claim is made against Indemnified arising out of this work, the Port shall have the right to deduct the same from the bill amount payable to the Indemnifier after verification of the validity and if admissible as per rules.

The Indemnifier shall ensure the use of PPE such as helmets, safety shoes, nose masks, hand gloves, safety harness or any other equipment as required depending on nature of work by his staff at site.

In addition to complying of the above, the Indemnifier hereby undertakes to indemnify the indemnified against any unforeseen incidents / accidents, which may lead to fatality including death, permanent/ partial disablement, injury, financial loss, legal issues or any other etc of the labourers / workmen’s/ staffs of the contractor / sub-contractor for which the indemnified and its officers / representation are in no way responsible.

For.....
INDEMINIFIER
(Signature with Name and Designation)
Company Seal

Station:
Date:
Witness:
1.....
Signature with Name, Designation & Address
2.....
Signature with Name, Designation & Address

Annexure-13

**Format for Self Certification under Preference to "MAKE
IN INDIA" Policy**

(Refer Clause No. 38 of ITT)

CERTIFICATE

In line with Government Public Procurement Order No. P-45021/2/2017-PP(B-II) dtd. 16-09-2020, as amended from time to time and as applicable on the date of submission of tender, we hereby certify that we M/s _____ (name of the Bidder) are local supplier meeting the requirement of minimum Local content (50%) as defined in above orders for the material against Tender NIT No _____ for the work of _____

Details of location at which local value addition will be made is as follows:

We also understand, false declarations will be in breach of the Code of Integrity under Rule 175(1)(i)(h) of the General Financial Rule for which for which a bidder or its successors can be debarred for up two years as per Rule 151 (iii) of the General Financial Rules along with such other actions as may be permissible under law. Seal and Signature of Authorized Signatory

Signature of the Bidder

Date :

Place :

SECTION - II

iii) FORM OF AGREEMENT

THIS AGREEMENT made the _____ day of _____
 20__ BETWEEN New Mangalore Port Authority (hereinafter called "the Employer") of
 the one part and _____

(hereinafter called "the Contractor") of the other part WHEREAS the Employer is
 desirous that certain works should be executed by the Contractor,
 Viz----- and has accepted a Tender by the Contractor for
 the execution and Completion of such works and the remedying of any defects
 therein at a contract price of Rs

NOW THIS AGREEMENT WITNESSETH as follows:

1. In this Agreement words and expressions shall have the same meanings as are respectively assigned to them in the General Conditions hereinafter referred to.
2. The following documents shall be deemed to form and be read and construed as part of this Agreement, viz. -
 - a) The Letter of Acceptance;
 - b) The Said Tender (Technical Bid);
 - c) The Conditions of Contract (Parts I and II)
 - d) The Specifications;
 - e) The Drawings;
 - f) The Bill of Quantities and
 - g) The Addenda
- h) Letters exchanged between the Employer and the Tenderer up to the issue of Letter of Acceptance as separately listed and annexed here to.
3. In consideration of the payments to be made by the Employer to the contractor as hereinafter mentioned the Contractor hereby covenants with the Employer to execute and complete the works and remedy any defects therein in conformity in all respect with the provisions of the Contract.
4. The Employer hereby covenants to pay the Contractor in consideration of the execution and completion of the works and the remedying of defects therein the Contract Price or and such other sum as may become payable under the Provisions of the Contract at the times and in the manner prescribed by the Contract.

IN WITNESS whereof the parties hereto have caused this Agreement to be executed the day and year first above written in accordance with their respective laws.

This document contains pages in all. This agreement is assigned No. CEA /20XX-XX.

The Common Seal of

was hereunto affixed in the presence of :

SECTION - III

iv) CONDITIONS OF CONTRACT

A. General**1. Definitions**

Terms which are defined in the Contract Data are not also defined in the Conditions of Contract but keep their defined meanings. Capital initials are used to identify defined terms.

Bill of Quantities means the priced and completed Bill of Quantities forming part of the Bid.

Compensation Events are those defined in Clause 44.

The Completion Date is the date of completion of the Works as certified by the Engineer or his nominee in accordance with Sub Clause 54

The Contract is the contract between the Employer and the Contractor to execute, complete and maintain the Works. It consists of the documents listed in Clause 2.3 below.

The Contract Data defines the documents and other information which comprise the Contract.

The Contractor is a person or corporate body whose Bid to carry out the Works has been accepted by the Employer.

The Contractor's Bid is the completed Bidding documents submitted by the Contractor to the Employer.

The Contract Price is the price stated in the letter of acceptance and thereafter as adjusted in accordance with the provisions of the Contract.

Days are calendar days, months are calendar months.

A Defect is any part of the Works not completed in accordance with the Contract.

The Defects Liability Period is the period named in the Contract Data and calculated from the Completion Date.

The Employer is the party who will employ the Contractor to carry out the Works.

Equipment is the Contractor's machinery and vehicles brought temporarily to the

Site to construct the Works.

The Initial Contract Price is the Contract Price listed in the Employer's Letter of Acceptance.

The Intended Completion Date is the date on which it is intended that the Contractor shall complete the works. The Intended Completion Date is specified in the Contract Data. The Intended Completion Date may be revised only by the Engineer or his nominee by issuing an extension of time.

Materials are all supplies, including consumables, used by the contractor for incorporation in the Works.

The Engineer or his nominee is the person named in the Contract Data (or any other competent person appointed and notified to the contractor to act in replacement of the Engineer or his nominee) who is responsible for supervising the Contractor, administering the Contract, certifying payments due to the Contractor, issuing and valuing Variations to the Contract, awarding extensions of time and valuing the Compensation Events.

Plant is any integral part of the Works which is to have mechanical, electrical, electronic or chemical or biological function.

The Site is the area defined as such in the Contract Data.

Site Investigation Reports are those which are included in the Bidding documents and are factual interpretative reports about the surface and sub-surface conditions at the site.

Specification means the Specification of the Works included in the Contract and any modification or addition made or approved by the Engineer or his nominee.

The Start Date is given in the Contract Data. It is the date when the Contractor shall commence execution of the works. It does not necessarily coincide with any of the Site Possession Date.

A Subcontractor is a person or corporate body who has a Contract with the Contractor to carry out a part of the work in the Contract which includes work on the Site.

Temporary Works are works designed, constructed, installed and removed by the Contractor which are needed for construction or installation of the Works.

A Variation is an instruction given by the Engineer or his nominee which varies the Works.

The Works are what the Contract requires the Contractor to construct, install and turn over to the Employer as defined in the Contract Data.

The Trained Work Person are those employed / proposed to be employed by the Contractor at the Project Site, who have participated and are in possession of a valid Competency Certificate through a programme run under the auspices of a University, State Technical Board, Ministry of Government of India.

2. Interpretation

- 2.1 In interpreting these Conditions of Contract, singular also means plural, male also means female or neuter and the other way around. Headings have no significance. Words have their normal meaning under the language of the Contract unless specifically defined. The Engineer or his nominee will provide instructions clarifying queries about the Conditions of Contract.
- 2.2 If sectional completion is specified in the Contract Data, references in the Conditions of Contract to the Works, the Completion Date, and the Intended Completion Date apply to any Section of the Works (other than references to the Completion Date and Intended Completion date for the whole of the Works).
- 2.3 The documents forming the Contract shall be interpreted in the following order of priority:
- (1) Agreement
 - (2) Letter of Acceptance and notice to proceed with works
 - (3) Contractor's Bid
 - (4) Contract Data
 - (5) Conditions of Contract including Special Conditions of Contract
 - (6) Specifications
 - (7) Drawings
 - (8) Bill of quantities and
- (9) Any other documents listed in the Contract Data as forming part of the Contract.

3. Language and Law

- 3.1 The language of the Contract and the law governing the Contract are stated in the Contract Data.

4. Engineer or his nominee's Decisions

- 4.1 Except where otherwise specifically stated, the Engineer or his nominee will decide contractual matters between the Employer and the Contractor in the role representing the Employer.

5. Delegation

- 5.1 The Engineer or his nominee may delegate any of the duties and responsibilities to other people after notifying the Contractor and may cancel any delegation after notifying the Contractor.

6. Communications

Communications between parties which are referred to in the conditions are effective only when in writing. A notice shall be effective only when it is delivered (in terms of Indian Contract Act 1872).

7. Contract Agreement

A suitable form is annexed as "FORM OF AGREEMENT" to the Contract Document. Upon signing the Contract Agreement, the Contractor shall make 12 copies of Contract Documents in hardbound cover which shall cover documents used in Contract/Agreement and provide the same to the Employer at no extra cost.

Data made available by the Employer in accordance with provisions of the Condition of Contract shall be deemed to include data listed elsewhere in the Contract and open for inspection at the office of the Deputy Chief Engineer (Civil) of the New Mangalore Port Authority (by prior appointment with the Engineer). Within 21 days of receipt of Letter of Acceptance, the successful bidder shall furnish the performance security and sign the Agreement with the Employer. However No work shall be commenced before signing of contract Agreement.

8. Subcontracting

- 8.1 The Contractor may subcontract with the approval of the Engineer or his nominee but may not assign the Contract without the approval of the Employer in writing. Subcontracting does not alter the Contractor's obligations.

Other Contractors

- 8.2 The Contractor shall co-operate and share the site with other contractors, public authorities, utilities, and the Employer between the dates given in the Schedule of other contractors. The Contractor shall as referred to in the Contract Data, also provide facilities and services for them as described in the Schedule. The employer may modify the schedule of other contractors and shall notify the contractor of any such modification.

9. Personnel

- 9.1 The Contractor shall employ the key personnel named in the Schedule of Key Personnel as referred to in the Contract Data to carry out the functions stated in the Schedule or other personnel approved by the Engineer or his nominee. The Engineer or his nominee will approve any proposed replacement of key personnel only if their qualifications, abilities, and relevant experience are substantially equal to or better than those of the personnel listed in the schedule.
- 9.2 If the Engineer or his nominee asks the contractor to remove a person who is a member of the contractor's staff of his work force stating the reasons, the contractor shall ensure that the person leaves the site within seven days and has no further connections with the work in the contract.

10. Employer's and Contractor's Risks

- 10.1 The Employer carries the risks which this Contract states are Employer's risks and the contractor carries the risks which this Contract states are contractor's risks.

11. Employer's Risks

11.1 The Employers risks are

In so far as they directly affect the execution of the Works in the country where the Permanent Works are to be executed:

- i) war and hostilities (whether war be declared or not), invasion, act of foreign enemies;
- ii) rebellion, revolution, insurrection, or military or usurped power, or civil war;
- iii) ionizing radiations, or contamination by radioactivity from any nuclear fuel, or from any nuclear waste, from the combustion of nuclear fuel, radioactive toxic explosive or other hazardous properties of any explosive nuclear

assembly or nuclear component thereof;

- iv) pressure waves caused by aircraft or other aerial devices travelling at sonic or Supersonic speeds; and
 - v) riot, commotion or disorder, unless solely restricted to the employees of the Contractor or of his Subcontractors and arising from the conduct of the Works;
 - vi) Unforeseen Rains (Rains if any; during the period other than the Monsoon period as stated in the Tender), floods, tornadoes, earthquakes and landslides.
- b) loss or damage due to the use or occupation by the Employer of any Section or part of the Permanent Works, except as may be provided for in the Contract;
 - c) loss or damage to the extent that it is due to the design of the Works, other than any part of the design provided by the Contractor or for which the Contractor is responsible; and
 - d) any operation of the forces of nature (in so far as it occurs on the Site) which an experienced contractor:
 - i) could not have reasonably foreseen, or
 - ii) could reasonably have foreseen, but against which he could not reasonably have taken at least one of the following measures:
 - iii) prevent loss or damage to physical property from occurring by taking appropriate measures, or
 - iv) insure against.

12. Contractor's Risks

12.1 All risks of loss of or damage to physical property and of personal injury and death which arise during and in consequence of the performance of the Contract other than the excepted risks are the responsibility of the Contractor.

13. Insurance

- 13.1 The Contractor shall provide in the joint names of the Employer and the Contractor, insurance cover from the Start Date to the end of the Defects Liability Period, in the amounts and deductibles stated in the Contract Data for the following events which are due to the Contractors risks.
- a) loss of or damage to the Works, Plant and Materials
 - b) loss of or damage to Equipment;
 - c) loss of or damage of property (except the Works, Plant, Materials and Equipment) in connection with the Contract; and
 - d) personal injury or death.
- 13.2 Policies and certificates for insurance shall be delivered by the contractor to the Engineer or his nominee for the Engineer or his nominee's approval before the start date. All such insurances shall provide for compensation to be payable in the types and proportions of currencies required to rectify the loss or damage incurred.
- 13.3 If the contractor does not provide any of the policies and certificates required, the Employer may affect the insurance which the contractor should have provided and

recover the premiums the Employer has paid from payments otherwise due to the contractor or, if no payment is due, the payment of the premiums shall be a debt due.

- 13.4 Alterations to the terms of insurance shall not be made without the approval of the Engineer or his nominee.

13.5 Both parties shall comply with all conditions of the insurance policies.

14. Site Investigation Reports

The Contractor, in preparing the Bid, shall rely on the Site Investigation Report referred to in the Contract Data, supplemented by any information available to the Bidder.

15. Queries about the Contract Data

The Engineer or his nominee will clarify queries on the Contract Data.

16. Contractor to Construct the Works

The Contractor shall construct and install the works in accordance with the Specification and Drawings.

17. The Works to Be Completed by the Intended Completion Date

The Contractor may commence execution of the works on the Start Date and shall carry out the works in accordance with the program submitted by the contractor as updated with the approval of the Engineer or his nominee, and complete them by the Intended Completion Date.

18. Approval by the Engineer or his nominee

- 18.1 The Contractor shall submit Specifications and Drawings showing the proposed Temporary Works to the Engineer or his nominee, who is to approve them if they comply with the specifications and Drawings.

18.2 The Contractor shall be responsible for design of Temporary Works.

18.3 The Engineer or his nominee's Approval shall not alter the contractor's Responsibility for design of the Temporary Works.

- 18.4 All Drawings prepared by the contractor for the execution of the temporary or permanent Works, are subject to prior approval by the Engineer or his nominee before their use.

19. Safety

The contractor shall be responsible for the safety of all activities on the Site.

20. Discoveries

Anything of historical or other interest or of significant value unexpectedly discovered on the Site is the property of the Employer. The Contractor is to notify the Engineer or his nominee of such discoveries and carry out the Engineer or his nominee's instructions for dealing with them.

21. Possession of the Site

The Employer shall give possession of all parts of the Site to the Contractor, free from encumbrances. If possession of a part is not given by the start date stated in the Contract Data the Employer is deemed to have delayed the start of the relevant

activities and this will be a Compensation Event.

22. Access to the Site

The Contractor shall allow the Engineer or his nominee and any person authorized by the Engineer or his nominee access to the Site to any place where work in connection with the Contract is being carried out or is intended to be carried out and to any place where materials or plant are being manufactured, fabricated and/or assembled for the works.

23. Instructions

The Contractor shall carry out all instructions of the Engineer or his nominee which comply with the applicable laws where the Site is located.

24. Disputes

If the Contractor believes that a decision taken by the Engineer or his nominee was either outside the authority given to the Engineer or his nominee by the Contract or that the decision was wrongly taken, the decision shall be referred to the Dispute Review Board (DRB) within 28 days of the notification of the Engineer or his nominee's decision.

25. Settlement of Disputes

25.1 If a dispute of any kind whatsoever arises between the Employer and the Contractor in connection with, or arising out of the Contract or the execution of the Works, whether during the execution of the Works or after their completion and whether before or after repudiation or after termination of the Contract, including any disagreement by either party with any action, inaction, opinion, instruction, determination, certificate or valuation of the Engineer or his nominee, the matter in dispute shall, in the first place be referred to the Disputes Review Board [DRB] established pursuant to Appendix 1 hereto. (Not applicable to this contract)

Unless the Contract has already been repudiated or terminated or frustrated the Contractor shall in every case, continue to proceed with the Works with all due diligence and the Contractor and the Employer shall give effect forthwith to every decision of the Engineer or his nominee unless and until the same shall be revised, as hereinafter provided, in a Dispute Review Board Recommendation / Arbitral Award.

25.2. Arbitration

Any dispute in respect of in respect of contracts where party is dissatisfied by the Dispute Review Board's (DRB) decision shall be decided by arbitration as set forth below:

- i) A dispute with contractor shall be finally settled by arbitration in accordance with the Indian Arbitration and Conciliation Act, 1996, or any statutory amendment thereof. The arbitral tribunal shall consist of 3 arbitrators, one each to be appointed by the Employer and the contractor, and the third to be appointed by the mutual consent of both the arbitrators, failing which by making a reference to CIDC-SIAC Arbitration Center from their panel.

- ii) Neither party shall be limited in the proceedings before such arbitrators to the evidence or arguments already put before the Engineer or his nominee or the Board, as the case may be, for the purpose of obtaining said recommendations/decision. No such recommendations/decision shall disqualify the Engineer or his nominee or any of the members of the Board, as the case may be, from being called as a witness and giving evidence before the arbitrators or any matter whatsoever relevant to the dispute.
- iii) The reference to arbitration shall proceed notwithstanding that the works shall not then be or be alleged to be complete, provided always that the obligations of the Employer, the Engineer or his nominee and the Contractor shall not be altered by reason of the arbitration being conducted during the progress of the works. Neither party shall be entitled to suspend the works to which the dispute relates, and payment to the Contractor shall be continued to be made as provided by the contract.
- iv) If one of the parties fails to appoint its arbitrators in pursuance of sub-clause [i], within 14 days after receipt of the notice of the appointment of its arbitrator by the other party, then President/Chairman of the nominated Institution shall appoint arbitrator within 14 days of the receipt of the request by the nominated institution. A certified copy of the President's/ Chairman's order, making such an appointment shall be furnished to both the parties.
- v) Arbitration proceedings shall be held at Mangalore, and the language of the arbitration proceedings and that of all documents and communications between the parties shall be 'English
- vi) The Arbitration shall be conducted by the experts from the panel of CIDCSIAC Arbitration Center.
- vii) The decision of the majority of arbitrators shall be final and binding upon both parties. The expenses of the arbitrators as determined by the arbitrators shall be shared equally by the Employer and the Contractor. However, the expenses incurred by each party in connection with the preparation, presentation, etc. of its case prior to, during and after the arbitration proceedings shall be borne by each party itself.
- viii) All arbitration awards shall be in writing and shall state the reasons for the award.
- ix) Performance under the contract shall continue during the arbitration proceedings and payments due to the contractor by the Employer shall not be withheld, unless they are subject matter of the arbitration proceedings.

26. Replacement of conciliator (deleted)

B. TIME CONTROL**27. Program**

- 27.1 Within the time stated in the Contract Data the Contractor shall submit to the Engineer or his nominee for approval a Program showing the general methods, arrangements, order, and timing for all the activities in the works along with monthly cash flow forecast.
- 27.2 An update of the Program shall be a program showing the actual progress achieved on each activity and the effect of the progress achieved on the timing of the remaining work including any changes to the sequence of the activities.
- 27.3 The Contractor shall submit to the Engineer on the first day of each week or such longer period as the Engineer may from time to time direct, a progress report in an approved form showing up-to-date total progress, progress achieved against planned progress, during the previous week and progress forecast for the following week for all important items in each section or portion of the Works, in relation with the approved Program.
- 27.4 The Contractor shall submit to the Engineer or his nominee, for approval an updated Program at intervals no longer than the period stated in the Contract Data. If the Contractor does not submit an updated Program within this period, the Engineer or his nominee may withhold the amount stated in the Contract Data from the next payment certificate and continue to withhold this amount until the next payment after the date on which the overdue Program has been submitted.

28. Revised Program

The Engineer or his nominee's approval of the Program shall not alter the Contractor's obligations. The Contractor may revise the Program and submit it to the Engineer or his nominee again at any time. A revised Program is to show the effect of Variations and Compensation Events.

29. Extension of the Intended Completion Date

- 29.1 The Engineer or his nominee shall extend the Intended Completion Date if a Compensation Event occurs or a Variation is issued which makes it impossible for Completion to be achieved by the Intended Completion Date without the Contractor taking steps to accelerate the remaining work and which would cause the Contractor to incur additional cost.
- 29.2 The Engineer or his nominee shall decide whether and by how much to extend the Intended Completion Date within 21 days of the Contractor asking the Engineer or his nominee for a decision upon the effect of a Compensation Event or Variation and submitting full supporting information. If the Contractor has failed to give early warning of a delay or has failed to cooperate in dealing with a delay, the delay by this failure shall not be considered in assessing the new Intended Completion Date.

30. Delays Ordered by the Engineer or his nominee

The Engineer or his nominee may instruct the Contractor to delay the start or

progress of any activity within the Works.

31. Management Meetings

- 31.1 Either the Engineer or his nominee or the Contractor may require the other to attend a management meeting. The business of a management meeting shall be to review the plans for remaining work and to deal with matters raised in accordance with the early warning procedure.
- 31.2 The Engineer or his nominee shall record the business of management meetings and is to provide copies of his record to those attending the meeting and to the Employer. The responsibility of the parties for actions to be taken is to be decided by the Engineer or his nominee either at the management meeting or after the management meeting and stated in writing to all who attended the meeting.

32. Early Warning

- 32.1 The Contractor is to warn the Engineer or his nominee at the earliest opportunity of specific likely future events or circumstances that may adversely affect the quality of the work, increase the Contract Price or delay the execution of works. The Engineer or his nominee may require the Contractor to provide an estimate of the expected effect of the event or circumstance on the Contract Price and Completion Date. The estimate is to be provided by the Contractor as soon as reasonably possible.
- 32.2 The Contractor shall cooperate with the Engineer or his nominee in making and considering proposals for how the effect of such an event or circumstance can be avoided or reduced by anyone involved in the work and in carrying out any resulting instruction of the Engineer or his nominee.

C. QUALITY CONTROL

33. Identify Defects

The Engineer or his nominee shall check the Contractor's work and notify the Contractor of any Defects that are found. Such checking shall not affect the Contractor's responsibilities. The Engineer or his nominee may instruct the Contractor to search for a Defect and to uncover and test any work that the Engineer or his nominee considers may have a Defect.

34. Tests

If the Engineer or his nominee instructs the Contractor to carry out a test not specified in the Specification to check whether any work has a Defect and the test shows that it does the Contractor shall pay for the test and any samples. If there is no Defect the test shall be a Compensation Event.

35. Defect Liability

35.1 The Engineer or his nominee shall give notice to the Contractor of any Defects before the end of the Defects Liability Period, which begins at Completion and is defined in the Contract Data. The Defects Liability Period shall be extended for as long as Defects remain to be corrected.

35.2 Every time notice of a Defect is given, the Contractor shall correct the notified defect within the length of time specified by the Engineer or his nominee's notice. To the intent that the works shall, at or as soon as practicable after the expiration of the Defects Liability Period, be delivered to the Employer in the condition required by the Contract, fair wear and tear excepted, to the satisfaction of the Engineer, the Contractor shall :

- (a) Complete the work, if any, outstanding on the date stated in the Taking-Over Certificate within the date to be intimated by the engineer and
- (b) execute all such work of amendment, reconstruction, and remedying defects, shrinkages or other faults as the Engineer may, during the Defects Liability Period or within 14 days after its expiration, as a result of an inspection made by or on behalf of the Engineer prior to its expiration, instruct the Contractor to execute.

35.3 Cost of Remedying Defects

All work referred to in Sub-Clause 35.2 shall be executed by the contractor at his own cost if the necessity thereof is, in the opinion of the Engineer, due to:

- a) The use of materials, Plant or workmanship not in accordance with the Contract, or
- b) Where the Contractor is responsible for the design of part of the Permanent Works, any fault in such design, or the neglect or failure on the part of the Contractor to comply with any obligation, expressed or implied, on the Contractor's part under the Contract.

35.4 Defects Liability Certificate

The Contract shall not be considered as completed until a Defects Liability Certificate shall have been signed by the Engineer and delivered to the Employer, with a copy to the Contractor, stating the date on which the Contractor shall have

completed his obligations to execute and complete the Works and remedy any defects therein to the Engineer's satisfaction. The Defects Liability Certificate shall be given by the Engineer within 28 days after the expiration of the Defects Liability Period, or, if different defects liability periods shall become applicable to different Sections or parts of the Permanent Works, the expiration of the latest such period, or as soon thereafter as any works instructed, pursuant to Clauses 35, have been completed to the satisfaction of the Engineer.

35.5 Unfulfilled Obligations

Notwithstanding the issue of the Defects Liability Certificate the Contractor and the Employer shall remain liable for the fulfillment of any obligation incurred under the provisions of the Contract prior to the issue of the Defects Liability Certificate which remains unperformed at the time such Defects Liability Certificate is issued and, for the purposes of determining the nature and extent of any such obligation, the Contract shall be deemed to remain in force between the parties to the Contract.

36. Uncorrected Defects.

If the Contractor has not corrected a Defect within the time specified in the Engineer or his nominee's notice the Engineer or his nominee will assess the cost of having the Defect corrected, and the Contractor will pay this amount.

D. COST CONTROL

37. Bill of Quantities

- 37.1 The Bill of Quantities shall contain items for the construction, supply, installation, testing and commissioning work to be done by the Contractor.
- 37.2 The Bill of Quantities is used to calculate the Contract Price. The Contractor is paid for the quantity of the work done at the rate in the Bill of Quantities for each item.

38. Changes in the Quantities

- 38.1 If the final quantity of the work done differs from the quantity in the Bill of Quantities for the particular item by more than +25 % provided the change exceeds +10% of initial Contract Price, the Engineer or his nominee shall adjust the rate(s), to allow for the change.
- 38.2 The Engineer or his nominee shall not adjust rates from changes in quantities if thereby the Initial Contract Price is exceeded by more than 15 percent except with the Prior approval of the Employer.
- 38.3 If requested by the Engineer or his nominee where the quoted rate(s) of any item(s) is abnormally high, the Contractor shall provide the Engineer or his nominee with a detailed cost breakdown of such rate in the Bill of Quantities.

39. Variations

- 39.1 The Engineer shall make any variation of the form, quality or quantity of the Works or any part thereof that may, in his opinion, be necessary and for that purpose, or if for any other reason it shall, in his opinion, be appropriate, he shall have the authority to instruct the Contractor to do and the Contractor shall do any of the following:
- a) increase or decrease the quantity of any work included in the Contract,
 - b) omit any such work,
 - c) change the character or quality or kind of any such work,
 - d) change the levels, lines, position and dimension of any part of the Works,
 - e) execute additional work of any kind necessary for the completion of the Works,
 - f) change any specified sequence or timing of construction of any part of the Works.

No such variation shall in any way vitiate or invalidate the Contract, by the effect, if any, of all such variations shall be valued in accordance with Clause 40. Provided that where the issue of an instruction to vary the works is necessitated by some default of or breach of contract by the contractor or for which he is responsible, any additional cost attributable to such default shall be borne by the contractor. All Variations shall be included in updated Programs produced by the contractor.

39.2 Instructions for Variations

The Contractor shall not make any such variation without an instruction of the Engineer. Provided that no instruction shall be required for increase or decrease in the quantity of any work where such increase or decrease is not the result of an instruction given under this clause, but is the result of the quantities exceeding or

being less than those stated in the Bill of Quantities.

40. Payments for Variations

- 40.1 Variation permitted shall not exceed +25% in quantity of each individual item, and +10% of the total contract price. Within 14 days of the date of instruction for executing varied work, extra work or substitution, and before the commencement of such work, notice shall be given either (a) by the contractor to the Employer of his intention to claim extra payment or a varied rate or price, or (b) by the Employer to the contractor of his intention to vary rate or price.
- 40.2 For items not existing in the Bill of Quantities or substitution to items in the Bill of Quantities, rate payable should be determined by methods given below and in the order given below:
- i) Rates and prices in Contract, if applicable plus escalation as per contract.
 - ii) Rates and prices in the Schedule of Rates applicable to the Contract plus ruling percentage.
 - iii) Market rates of materials and labor, hire charges of plant and machinery used, plus 10% for overheads and profits of contractor.
- 40.3 For items in the Bill of Quantities but where quantities have increased beyond the variation limits, the rate payable for quantity in excess of the quantity in the Bill of Quantity plus the permissible variation should be:
- i) Rates and prices in contract, if reasonable plus escalation, failing which (ii) and (iii) below will apply
 - ii) Rates and prices in the schedule of Rates applicable to the contract plus ruling percentage.
 - iii) Market rates of material and labor, hire charges of plant and machinery used plus 10% for overheads and profits of contractor.
- 40.4 If there is delay in the Employer and the Contractor coming to an agreement on the rate of an extra item, rates as proposed by the Employer shall be payable provisionally till such time as the rates are finally determined or till date mutually agreed.
- 40.5 If the Engineer or his nominee decides that the urgency of varying the work prevent a quotation being given and considers not delaying the work, no quotation shall be given and the Variation shall be treated as a Compensation Event.

41. Cash flow forecasts

- 41.1 When the Program is updated, the contractor is to provide the Engineer or his nominee with an updated cash flow forecast.

42. Payment Certificates

- 42.1 The Contractor shall submit to the Engineer or his nominee monthly statements of the estimated value of the work completed less the cumulative amount certified previously.
- 42.2 The Engineer or his nominee shall check the Contractors' monthly statement within 14 days and certify the amount to be paid to the Contractor after taking into account

any credit or debit for the month in question in respect of materials for the works in the relevant amounts and under conditions set forth in sub-clause 51.6 of the Contract Data (Secured Advance).

42.3 The value of work executed shall be determined by the Engineer or his nominee.

42.4 The value of work executed shall comprise the value of the quantities of the items in the Bill of quantities completed.

42.5 The value of work executed shall include the valuation of variations and Compensation Events.

42.6 The Engineer or his nominee may exclude any item certified in a previous certificate or reduce the proportion of any item previously certified in any certificate in the light of later information.

43. Payments

- 43.1 The bills for other Construction/Renovation/Miscellaneous works which are not paid on monthly basis the Contractor has to submit the bill within 7 days of joint measurement taken along with the concerned Engineer. The Engineer has to ensure that joint measurement to be completed within 7 days of completing of part work / running work. The concerned Engineer i/c shall check and make entries into bill/M.B within 10 days of submission of the interim bill and submit to Executive Engineer/ Superintending Engineer (Civil). The Executive Engineer/ Superintending Engineer (Civil) shall check the bills and after certification of the quantities as per manual shall forward to the Finance Department within 3 working days. The Contractor and Assistant Engineer both jointly complete the measurements, if Contractor due to any reason does not attend/avoid joint survey/measurements the Executive Engineer shall give notice to the contractor to be present at the site for joint measurement within 7 days notice. If the contractor fails to attend the joint measurement second notice shall be issued to the contractor to attend the joint measurement within 3 days failure to attend the site for joint measurement the Assistant Engineer and AEE or EE would record the reason and complete the measurements in a transparent manner departmentally and submit the bill. Bills / Tax invoice shall be prepared and submitted by the Contractor. Joint measurements shall be taken continuously and need not be connected with billing stage. System of 4 copies of measurements, one each for Contractor, Employer and Engineer or his nominee, and signed by both Contractor and Employer shall be followed.
- 43.2 Interim of bill amount will be paid within 14 days of submission of the bill.
- 43.3 Contractor shall submit final Bill within 60 days from the date of completion of work and the same will be paid by the Port within 30 days from the date of submission
- 43.4 The payment will be made to the contractor after deducting any dues payable to the Port statutory authorities etc
- 43.5 If an amount certified is increased in a later certificate as a result of an award by the DRB or an Arbitrator, the Contractor shall be paid interest upon the delayed payment as set out in this clause. Interest shall be calculated from the date upon which the increased amount would have been certified in the absence of dispute.
- 43.6 Items of the Works for which no rate or price has been entered in will not be paid for by the Employer and shall be deemed covered by other rates and prices in the Contract.

44. Compensation Events

- 44.1 The following mutually agreed Compensation Events unless they are caused by the Contractor would be applicable:
- (a) The Employer does not give access to a part of the Site by the Site Possession Date stated in the Contract Data.
 - (b) The Employer modifies the schedule of other contractors in a way which affects the

- work of the contractor under the contract.
- (c) The Engineer or his nominee orders a delay or does not issue drawings, specifications or instructions required for execution of works on time.
 - (d) The Engineer or his nominee instructs the Contractor to uncover or to carry out additional tests upon work which is then found to have no Defects.
 - (e) The Engineer or his nominee unreasonably does not approve for a subcontract to be let.
 - (f) Ground conditions are substantially more adverse than could reasonably have been assumed before issuance of Letter of Acceptance from the information issued to Bidders (including the Site Investigation Reports), from information available publicly and from a visual inspection of the site.
 - (g) The Engineer or his nominee gives an instruction for dealing with an unforeseen condition, caused by the Employer, or additional work required for safety or other reasons.
 - (h) Other contractors, public authorities, utilities or the Employer does not work within the dates and other constraints stated in the Contract that cause delay or extra cost to the Contractor.
 - (i) The effect on the Contractor of any of the Employer's Risks.
 - (j) Other Compensation Events listed in the Contract Data or mentioned in the contract.

Whenever any compensation event occurs, the contractor will notify the employer, within 14 days and provide a forecast cost of the compensation event.

44.2 If a Compensation Event would cause additional cost or would prevent the work being completed before the Intended Completion Date, the Contract Price shall be increased and/or the Intended Completion Date shall be extended. The Engineer or his nominee shall decide whether and by how much the Contract Price shall be increased and whether and by how much the Intended Completion Date shall be extended.

44.3 As soon as information demonstrating the effect of each Compensation Event upon the Contractor's forecast has been provided by the Contractor, it is to be assessed by the Engineer or his nominee and the Contract Price shall be adjusted accordingly. If the Contractor's forecast is deemed unreasonable the Engineer or his nominee shall adjust the Contract Price based on Engineer or his nominee's own forecast. The Engineer or his nominee will assume that the Contractor will react competently and promptly to the event.

45. Tax

45.1 The rates quoted by the Contractor to be inclusive of taxes if any excluding GST that the Contractor will have to pay for the performance of this Contract. The Employer will perform such duties in regard to the deduction of such taxes at sources as per applicable law. Any new Taxes, levies, duties imposed after signing the Contract shall be reimbursed by the employer on production of documentary evidence. The GST

shall be quoted separately in tax invoice. The contractor shall file the applicable returns with tax department in time and submit the same as documentary evidence.

46. Currencies

46.1 All payments shall be made in Indian Rupees unless specifically mentioned.

47. Price Adjustment. (Not Applicable)

48. Retention

48.1 The Employer shall retain from each payment due to the Contractor the proportion stated in the Contract Data until Completion of the whole of the Works.

48.2 Retention Money shall be deducted at the rate of 10% of the total tax invoice, from first Running Bill onwards subject to a max of 5% plus of the contract price including GST. Retention money shall be refunded after completion of defect liability period along with performance security.

49. Liquidated Damages

49A In case of delay in completion of the contract, liquidated damages (L.D) may be levied at the rate of half per cent (½%) of the contract price per week of delay, or part thereof subject to a maximum of 10 per cent of the contract price.

49A(i) The Employer, if satisfied, that the works can be completed by the contractor within a reasonable time after the specified time for completion, may allow further extension of time at its discretion with or without the levy of L.D. In the event of extension granted being with L.D, the Employer will be entitled without prejudice to any other right or remedy available in that behalf, to recover from the contractor as agreed damages equivalent to half per cent (½%) of the contract value of the works including GST for each week or part of the week subject to the ceiling defined in sub-Clause 49 A.

In the event of forfeiting the LD / EMD / SD performance Guarantee and while imposing penalty GST at applicable rate is applicable.

49A(ii) The Employer, if not satisfied that the works can be completed by the contractor, and in the event of failure on the part of the contractor to complete work within further extension of time allowed as aforesaid, shall be entitled, without prejudice to any other right, or remedy available in that behalf, to rescind the contract.

49A(iii) The Employer, if not satisfied with the progress of the contract and in the event of failure of the contractor to recoup the delays in the mutually agreed time frame, shall be entitled to terminate the contract.

49A(iv) In the event of such termination of the contract as described in clauses 49A(ii) or 49A(iii) or both the Employer shall be entitled to recover L.D. up to ten per cent (10%) of the contract value and forfeit the security deposit made by the contractor besides getting the work completed by other means at the risk and cost of the contractor.

49A(v) In case Part / portions of the work can be commissioned and the Port operates the

portion for commercial purposes, the rate of LD will be restricted to the uncompleted value of work, the maximum LD being on the entire contract value.

50. Nominated Subcontractors

All specialists, merchants, tradesmen and others executing any work or supplying any good, materials, Plant or services for which provisional Sums are included in the Contract, who may have been or be nominated or selected or approved by the Employer or the Engineer, and all persons to whom by virtue of the provisions of the Contract, the Contractor is required to subcontract shall, in the execution of such work or the supply of such goods, materials, Plant or services, be deemed to be subcontractors to the Contractor and are referred to in this Contract as "Nominated Subcontractors".

51. Advance payment (Not Applicable)

The Employer shall make the following advance payments:

- 51.1 Mobilization Advance shall be paid up to 10% of Contract price, payable in two equal installments. The first installment shall be paid after mobilization has started and next installment shall be paid after satisfactory utilization of earlier advance.
- 51.2 Construction / installation equipment Advance shall be paid up to 5% of Contract price, limited to 90% of assessed cost of machinery.
- 51.3 Mobilization Advance and Construction Equipment Advance shall be paid at SBI PLR + 2% p.a. (as on date of payment) interest rate at the discretion of the employer and against Bank Guarantee for Mobilization Advance and against hypothecation of Construction Equipment to the Employer.
- 51.4 Equipment advance will be paid in two or more installments. First installment shall be paid after Construction Equipment has arrived at the site and next installment shall be paid after satisfactory utilization of earlier advance (s).
- 51.5 Recovery of Mobilization and Construction Equipment advance will start when 15% of the work is executed and recovery of total advance should be completed by the time 80% of the original Contract work is executed.
- 51.6 Secured Advance :The Engineer or his nominee shall make advance payment in respect of materials and plant brought to site but not yet incorporated and installed in the Works in accordance with conditions stipulated in the Contract Data. 75% of cost of materials and plant brought to site for incorporation into the works only shall be paid as Secured Advance. Materials which are of perishable nature should be adequately insured.

52. Securities

- 52.1 Security deposit shall consist of two parts
 - (a) Performance security to be submitted at award of the work
 - (b) Retention Money to be recovered from Running Bills.
- 52.2 The Security deposit at 10% of the contract amount including GST, of which 5% of contract price should be submitted as performance security within 21 days of receipt of letter of acceptance and balance 5% recovered as retention money from running

bills. Recovery of 5% of retention money shall commence from the first RA bill onwards @ 10% for each bill. Retention money shall be refunded after completion of defect liability period. The performance Bank Guarantee will be released after completion of defect liability period.

53. Removal of Craft or Plant which has sunk (not applicable to this contract)

The Contractor shall forthwith and with dispatch at his own cost raise and remove any craft or plant (floating or otherwise) belonging to him or to any sub-contractor employed by him (including also any plant which is held by the Contractor or any sub-contractor under agreement for hire or hire-purchase) which may be sunk in the course of the construction completion or maintenance of the Works or otherwise deal with the same as the Engineer may direct or until the same shall be raised and removed, the contractor shall set at such buoys and display at night such lights and do all such things for the safety of navigation as may be required by the Engineer or by Employer. In the event of the Contractor not carrying out his obligation imposed upon him by this clause the Employer may provide buoy and light such sunken craft or plant and raise and remove the same (without prejudice to the right of the Employer to hold the Contractor liable under General Conditions) and the Contractor shall refund to the Employer all costs incurred in connection therewith.

Contractor's Temporary Moorings

Should the Contractor need, in connection with implementing the Works, to provide temporary moorings for his craft he may be allowed to do so in location and manner approved by the Engineer subject to all necessary permissions being first obtained by the Contractor from the authorities concerned. The Contractor shall not lay his temporary moorings such as to interfere with the port traffic and such moorings shall be removed if and when required by the Employer.

54. Cost of Repairs

- 53.1 Loss or damage to the Works or Materials to be incorporated in the Works between the Start Date and the end of the Defects Correction period shall be remedied by the Contractor at the Contractor's cost if the loss or damage arises from the Contractor's acts or omissions.

E. FINISHING THE CONTRACT

55. Completion

After completion of the work, the contractor will serve a written notice to the Engineer or his nominee/Employer to this effect. The Engineer or his nominee/Employer upon receipt of this notice shall conduct a complete joint survey of the work within 7 days and prepare a defects list jointly. The defects pointed out by the Engineer or his nominee/Employer would be rectified by the contractor within 14 days and thereafter acceptance report be signed jointly by the contractor and the Employer. This joint acceptance report shall be treated as 'Completion Certificate'.

Substantial Completion of Parts

If any part of the Permanent Works has been substantially completed and satisfactorily passed any Tests on Completion prescribed by the Contract, the Engineer may issue a Taking-Over Certificate in respect of that part of the Permanent works before completion of the whole of the Works and, upon the issue of such Certificate, the Contractor shall be deemed to have undertaken to complete with due expedition any outstanding work in that part of the Permanent Works during the Defects Liability Period.

Surfaces Requiring Reinstatement

Provided that a Taking-Over Certificate given in respect of any Section or part of the Permanent Works before completion of the whole of the Works shall not be deemed to certify completion of any ground or surfaces requiring reinstatement, unless such Taking-Over Certificate shall expressly so state.

56. Taking Over

The Employer shall take over the Site and the Works within seven days of the Engineer or his nominee issuing a certificate of Completion.

Taking-Over Certificate

When the whole of the Works have been substantially completed and have satisfactorily passed any Tests on Completion prescribed by the Contract, the Contractor may give a notice to that effect to the Engineer, with a copy to the Employer, accompanied by a written undertaking to finish with due expedition any outstanding work during the Defects Liability Period. Such notice and undertaking shall be deemed to be a request by the Contractor for the Engineer to issue a Taking-over Certificate in respect of the Works. The Engineer shall, within 21 days of the date of delivery of such notice, either issue to the Contractor, with a copy to the Employer, a Taking-Over Certificate, stating the date on which, in his opinion, the Works were substantially completed in accordance with the Contract, or give instruction in writing to the Contractor specifying all the work which in the Engineer's opinion, is required to be done by the Contractor before the issue of such Certificate. The Engineer shall also notify the Contractor of any defects in the Works affecting substantial completion that may appear after such instructions and before completion of the Works specified therein. The Contractor shall be entitled to receive such Taking-Over Certificate within 21 days of completion, to the satisfaction of the Engineer, of the Works so specified and remedying any defects so notified.

Taking Over of Sections or Parts

Similarly, in accordance with the procedure set out in above Clause, the Contractor may request and the Engineer shall issue a Taking-Over Certificate in respect of :

- a. any Section in respect of which a separate Time for Completion is provided in the appendix to Tender, or
- b. any substantial part of the Permanent Works which has been both completed to the satisfaction of the Engineer and, otherwise than as provided for in the Contract,

- occupied or used by the Employer, or
- c. any part of the Permanent Works which the Employer has elected to occupy or use prior to completion (where such prior occupation or use is not provided for in the Contract or has not been agreed by the Contractor as a temporary measure).

57. Final Account

The Contractor shall supply to the Engineer or his nominee a detailed account of the total amount that the Contractor considers payable under the Contract before the end of the Defects Liability Period. The Engineer or his nominee shall issue a Defects Liability Certificate and certify any final payment that is due to the Contractor within 60 days of receiving the Contractor's account if it is correct and complete. If it is not, the Engineer or his nominee shall issue within 15 days a schedule that states the scope of the corrections or additions that are necessary for the correction and certify payment of 50% of the undisputed amount to the contractor. If the Final Account is still unsatisfactory after it has been resubmitted the Engineer or his nominee shall decide on the amount payable to the Contractor and issue a payment certificate, within 60 days of receiving the Contractor's revised account.

58. Submission of 'As built Drawings'

"As built" Drawings are required to be submitted by the Contractor and shall be supplied by them by the dates stated in the Contract Data. If the Contractor does not supply the Drawings and/or manuals by the dates stated in the Contract Data, or they do not receive the Engineer or his nominee's approval, the Engineer or his nominee shall withhold the amount stated in the Contract Data from payments due to the Contractor.

59. Termination

- 59.1 The Employer or the Contractor may terminate the Contract if the other party causes a fundamental breach of the Contract.
- 59.2 Fundamental breaches of Contract include, but shall not be limited to the following:
- (a) The Delay in signing of contract agreement beyond prescribed time limit.
 - (b) The Contractor stops work for 28 days when no stoppage of work is shown on the current Program and the stoppage has not been authorised by the Engineer or his nominee.
 - (c) the Engineer or his nominee instructs the Contractor to delay the progress of the Works and the instruction is not withdrawn within 28 days.
 - (d) the Employer or the Contractor becomes bankrupt or goes into liquidation other than for a reconstruction restructure or amalgamation.
 - (e) a payment certified by the Engineer or his nominee is not paid by the Employer to the Contractor within 50 days of the date of the Engineer or his nominee's certificate:
 - (f) the Engineer or his nominee gives Notice that failure to correct a particular Defect is a fundamental breach of Contract and the Contractor fails to correct it within a reasonable period of time determined by the Engineer or his

nominee.

(g) the Contractor does not maintain a security which is required.

(h) the Contractor has delayed the completion of works by the number days for which the maximum amount of liquidated damages can be paid as defined in the Contract data and

(i) if the Contractor, in the judgment of the Employer has engaged in corrupt or fraudulent practices in competing for or in the executing the Contract.

For the purpose of this paragraph: "corrupt practice" means the offering, giving, receiving or soliciting of any thing of value to influence the action of a public official in the procurement process or in contract execution. "Fraudulent practice" means a misrepresentation of facts in order to influence a procurement process or the execution of a contract to the detriment of the Employer, and includes collusive practice. Bidders (prior to or after bid submission) designed to establish bid prices at artificial non-competitive levels and to deprive the Employer of the benefits of free and open competition."

59.3 When either party to the Contract gives notice of a breach of contract to the Engineer or his nominee for a cause other than those listed under Sub Clause 59.2 above, the Engineer or his nominee shall decide whether the breach is fundamental or not.

59.4 Notwithstanding the above, the Employer may terminate the Contract for convenience subject to payment of compensation to the contractor including loss of profit on uncompleted works. Loss of profit shall be calculated on the same basis as adopted for calculation of extra/additional items.

59.5 If the Contract is terminated the Contractor shall stop work immediately, make the Site safe and secure and leave the Site as soon as reasonably possible.

60. Payment upon Termination

60.1 If the Contract is terminated because of a fundamental breach of Contract by the Contractor, the Engineer or his nominee shall issue a certificate for the value of the work done less advance payments received up to the date of the issue of the certificate, less other recoveries due in terms of the contract, less taxes due to be deducted at source as per applicable law and less the percentage to apply to the work not completed as indicated in the Contract Data. Additional Liquidated Damages shall not apply. If the total amount due to the Employer exceeds any payment due to the Contractor, the difference shall be a debt payable to the Employer.

60.2 If the Contract is terminated at the Employer's convenience or because of a fundamental breach of Contract by the Employer, the Engineer or his nominee shall issue a certificate for the value of the work done, the reasonable cost of removal of Equipment repatriation of the Contractor's personnel employed solely on the Works, and the Contractor's costs of protecting and securing the Works and loss of profit on uncompleted works less advance payments received up to the date of the certificate,

less other recoveries due in terms of the contract and less taxes due to be deducted at source as per applicable law.

61. Property

All materials on the Site, Plant, Equipment, Temporary Works and Works for which payment has been made to the contractor by the Employer, are deemed to be the property of the Employer, if the Contract is terminated because of a Contractor's default.

62. Release from Performance

If the Contract is frustrated by the outbreak of war or by other event entirely outside the control of either the Employer or the Contractor, the Engineer or his nominee shall certify that the Contract has been frustrated. The Contractor shall leave the Site and stop work as quickly as possible after receiving this certificate and shall be paid for all work carried out before receiving it and for any work carried out afterwards to which commitment was made.

F. SPECIAL CONDITIONS OF CONTRACT

The conditions of contract shall be the general conditions of contract in Section-III (v) as modified or added by the following condition of special conditions as provided in Section – III(vi) herein, which shall be read and construed with the general condition in Section – 3 A to E as if they were incorporated therein. In so far as any of the condition of the special conditions may conflict or be in consisting with any of general conditions of in Section -3F- Special condition of the contract shall prevail.

63. Labour

The Contractor shall, unless otherwise provided in the Contract, make his own arrangements for the engagement of all staff and labour, local or other, and for their payment, housing, feeding and transport.

The Contractor shall, if required by the Engineer or his nominee, deliver to the Engineer or his nominee a return in detail, in such form and at such intervals as the Engineer or his nominee may prescribe, showing the staff and the numbers of the several classes of labour from time to time employed by the Contractor on the Site and such other information as the Engineer or his nominee may require.

64. Compliance with labour regulations

During continuance of the contract, the Contractor and his sub contractors shall abide at all times by all existing labour enactment and rules made there under, regulations, notifications and bye laws of the State or Central Government or local authority and any other labour law (including rules) regulations, bye laws that may be passed or notification that may be issued under any labour law in future either by the State or Central Government or the local authority. Salient features of some of the major labour laws that are applicable to construction industry are given below. The Contractor shall keep the Employer indemnified in case any action is

taken against the Employer by the competent authority on account of contravention of any of the provisions of any Act or rules made there under, regulations or notifications including amendments. If the Employer is caused to pay or reimburse such amounts as may be necessary to cause or observe, or for non-observance of the provisions stipulated in the notifications/bye laws/Acts/Rules/regulations including amendments, if any, on the part of the Contractor the Engineer or his nominee/Employer shall have the right to deduct any money due to the Contractor including his amount of performance security. The Employer / Engineer or his nominee shall also have right to recover from the Contractor any sum required or estimated to be required for making good the loss or damage suffered by the Employer. The employees of the Contractor and the Sub-Contractor in no case shall be treated as the employees of the Employer at any point of time.

65. Safety, Security and Protection of the Environment.

Subject and without prejudice to any other provision of the Contract, the Contractor shall take all reasonable precautions:

- (a) In connection with underground water resources (including percolating water) to prevent
 - (b) Any interference with the supply to or abstraction from such sources
 - (c) Pollution of the water so as to affect adversely the quality thereof.
- (d) All works shall be carried out without unreasonable noise and disturbance. The Contractor shall indemnify the Employer from and against any liability for damages on account of noise or other disturbance created while or in carrying out the work and from and against all claims, demands, proceedings, damages, costs, charges and expenses whatsoever in regard or in relation to such liability.
- (e) The Contractor at his own cost shall make such provisions for lighting of Works, Temporary Works, Materials and Plant and shall provide all such marks and lights as may be required by the Employer or the Engineer or any other authority having jurisdiction over the Site together with all labour stores and services required for their efficient working and use at any time, day or night.
 - (f) The Contractor shall also provide at his own cost every description of watching and maintenance required in connection with the foregoing, and all other services for protecting and securing all places dangerous whether to Contractor's workmen or to other persons until the Works are handed over to the Employer, or till such time when the Engineer decides that such services are no longer required. All lights provided by the Contractor shall be placed or screened such as not to interfere with any navigation lights or with any traffic or signal lights of any local or other authority.

66. Insurance of Works and Contractor's Equipment

The Insurance shall be issued by Nationalized Insurance Company from its Mangalore Branch which has been determined by the Contractor to be acceptable to the Employer.

The contractor shall at his own costs and expenses obtain and shall cause any subcontractor to obtain such insurance as may be necessary to cover the liability of the contractor or as the case may be of such subcontractor in respect of personal injuries and death arising out of or in the course of or caused during the execution of the works for a minimum amount of Rs. 25 lakhs and shall produce or cause any such subcontractor to produce for inspection the relevant policy or policies together with receipt for the premium paid under such policy/policies as and when required by the Employer.

- i. The Employer (NMPA) shall not be liable for any accident, damage or compensation payable to any workman or other person in the employment of the Contractor or any Subcontractor.
- ii. Employer Liability Insurance: The Contractor shall indemnify and keep indemnified the Employer i.e. NMPA against all damages or compensation payable at Law in respect of or in consequence of any accident or injury to any workman or other person in the employment of the Contractor or Sub-Contractor against all claims, demands, proceedings, costs, charges and expenses whatsoever in respect thereof or in relation thereto and the Employer shall be at liberty to deduct or adjust from the Contractor's bills an amount that Employer may be called upon to pay towards claims, demands, proceedings, costs, charges and expenses Whatsoever in respect of or in relation to any accident or injury referred to above without any reference to the Contractor.
- iii. The Contractor shall comply with all the Central State and Municipal Laws and Rules and shall be solely responsible for complying with the provisions of the Contract Labour (Regulations & Abolition) Act, 1970 & the contract labour (Regulation & Abolition) Karnataka Rules 1974 and rules there under and the enactments that may be applicable including ESI Act, the payment of wages act, Provident Fund Act, the Minimum Wages Act, the Factory's Act. The Workmen Compensation Act or any other applicable legislation and the Municipal by-laws or other statutory Rules and Regulations whatsoever in force if these are applicable. Any obligations finding or otherwise missed under any statutory enactments, rules & regulations there under shall be the responsibility of the Contractor and the NMPA will take no responsibility for the same. The Contractor should take Workmen's Compensation Policy for his Workers, who are not covered under ESI and submit the same to the EIC immediately after commencement of the work.
- iv. The Contractor is liable to pay all Statutory Compensation to the Labourers/persons engaged by him for the satisfactory execution of the works. If any claim is made against New Mangalore Port Authority on this work, the Port Authority shall have the right to deduct the same from the bill amount payable to the contractor after verification of the validity and if admissible as per rules.
- v. PERSONAL PROTECTIVE EQUIPMENTS The Contractor shall ensure the use of PPE such as helmets, safety shoes, nose masks, hand gloves, Safety Harness or any other equipment as required depending on nature of work by his staff at site.

67. War Risks Insurance

If the Contractor receives instructions from the Employer to insure against war risks, such insurance if normally available shall be effected, at the cost of the Employer, with the Insurance Company acceptable to the Employer and shall be in the joint names of the Employer and the Contractor.

68. Royalty

Except where otherwise stated, the contractor shall pay to the authority all tonnage and other royalties, rent and other payments or compensation if any, for getting stone, sand, gravel, clay or other materials by him and his subordinates and his subcontractors and required for the works, at the rates and such conditions as notified by the State Government. The applicable rates for royalty is enclosed as Schedule-A in Volume -III. The contractor should submit the Mineral Dispatch Permit (MDP) in original for the quantity executed by the contractor for the requisite quantity of material incorporated in works for which MDP is issued by the authorized supplier. If contractor fails to submit the MDP in original the amount equal to 5 times the royalty charges shall be deducted from the contractor's bills as per prevailing orders issued by the Authority.

69. Transport of Contractor's Equipment or Temporary Works

If it is found necessary for the Contractor to move one or more loads of heavy constructional plant or equipment materials or pre-constructed units or parts of units of work over roads, highways or bridges on which such oversized and over weight items are not normally allowed to be moved, the Contractor shall obtain prior permission from the concerned authorities. Payments for complying with the requirements, if any, for protection of or strengthening of the roads, highways or bridges shall be deemed to be included in his contract price.

70. Transport of Materials or Plant

The contractor shall save harmless and indemnify the Employer in respect of all claims, proceedings, damages, costs, charges and expenses whatsoever arising out of or in relation to any claim made by the concerned authorities in respect of damage or injury to roads, highways or bridges. In case of failure of the Contractor to settle such claims and in case the Employer is held responsible for payment to the authorities, then the Employer shall settle the claim and the Employer's expenses in this regard, as certified by the Engineer, may be deducted by the Employer from any money due or to become due to the Contractor and the Engineer shall notify the Contractor accordingly with a copy to the Employer.

71. Labor Laws & Regulations

The Contractor shall at all times during the continuance of the Contract comply fully with all existing Acts, regulations and bye-laws including all statutory amendments and re-enactment of State or Central Govt. and other local authorities and any other enactments and act that may be passed in future either by the State or the Central Govt. or local authority, including Indian Workmen's Compensation Act, Contract Labour (Regulation And Abolition) Act 1970 and Equal Remuneration Act 1976, Employees' State Insurance Act, 1948, Factories Act, Minimum Wages Act, Provident Fund Regulations. Employees' Provident Fund Act and schemes made under the same Act, Health and Sanitary Arrangements for Workmen, Insurance and other

benefits and shall keep the Employer indemnified in case any action is commenced for contravention by the Contractor. If the Employer is caused to pay or reimburse any amounts as may be necessary to cause or observe, or for non-observance of the provisions stipulated here-forth on the part of the Contractor, the Engineer shall have the right to recover from the Contractor any sum required estimated to be required for making good the loss or damage suffered by the Employer. The Tenderers must have valid ESI and PF registration and shall maintain the records prescribed under ESI Regulations and PF Act & make the contribution towards ESI and PF in respect of persons employed by the Contractor. The contractor shall make available such records for inspection by ESI and PF authorities during inspection and furnish the copies of such records to the employer regularly. The EPF and ESI contribution on the part of the employer in respect of this contract shall be paid by the contractor. These contributions on the part of Employer paid by the contractor shall be reimbursed by the Engineer –in –charge to the contractor on actual basis. The minimum wages applicable for Mangalore City is enclosed as Schedule – B in Volume – III.

71.1. Accident Prevention/Safety Officer

The Contractor shall have on his staff on site an officer dealing with all matters regarding safety and protection against, accidents of all staff and labour. This officer shall be qualified for this work and shall have the authority to issue instructions and shall take protective measures to prevent accidents.

71.2 Disorderly Conduct

The Contractor shall at all times take all reasonable precautions to prevent any unlawful, riotous or disorderly conduct by or amongst his staff and labour and for the preservation of peace and protection of Persons and property in the neighborhood of the Works from the same.

71.3 Health and Safety

Due precautions shall be taken by the Contractor, and at his own cost, to ensure the safety of his staff and labour and, in collaboration with and to the requirements of the local health authorities, to ensure that medical staff, first aid equipment and stores, sick bay and suitable ambulance services are available at the camps, housing and on the site at all times throughout the period of the Contract and that suitable arrangements are made for the prevention of epidemics and for all necessary welfare and hygiene requirements.

71.4 Supply of Water

The Contractor shall, so far as is reasonably practicable, having regard to local conditions provide on the Site, to the satisfaction of the Engineer's Representative, an adequate supply of drinking and other water for the use of the Contractor's staff and work people.

71.5 Alcoholic Liquor or Drugs

The Contractor shall not, otherwise than in accordance with the Statues, Ordinances and Government Regulations or Orders for the time being in force, import, sell, give, barter or otherwise dispose of any alcoholic liquor, or drugs or permit or suffer any such importation, sale, and gift, barter disposal by his sub-contractions agents or employees.

71.6 Arms and Ammunition

The Contractor shall not give, barter or otherwise dispose of to any persons or person, any arms or ammunition of any kind or permit or suffer the same as aforesaid.

71.7 Festivals and Religious Customs

The Contractor shall in all dealings with labour in his employment have due regard to all recognized festivals, days of rest and religious or other customs.

71.8 Epidemics

In the event of any outbreak of illness of an epidemic nature, the Contractor shall comply with and carry out such regulations, orders and requirements as may be made by the Govt., or the local medical or sanitary authorities for the purpose of dealing with and overcoming the same.

71.9 Employment of Person in the Service of Others

The Contractor shall not recruit or attempt to recruit his staff and labour from amongst persons in the service of the Employer or other agencies engaged for any works of the Employer.

71.10 Housing for Labour

Save in so far as the Contract otherwise provides, the Contractor shall provide and maintain such accommodation and amenities as he may consider necessary for all his staff and labour employed for the purposes of or in connection with the Contract, including all fencing water supply (both for drinking and other purposes), electricity supply, sanitation, cook houses fire prevention and fire-fighting equipment, **crèche for children** of his staff and labour employed for the purposes, furniture, other requirements in connection with such accommodation or amenities. On completion of the Contract, unless otherwise agreed with the Employer, the temporary camps/housing provided by the Contractor shall be removed and the site reinstated to its original condition, all to the approval of the Engineer. The land for construction of labour camps shall be allotted outside the security area to the extent available and such area allotted for labour camps will be charged a ground rent at TAMP approved rates. The ground rent is liable for change as per the prevailing TAMP rates from time to time during the currency of the contract.

71.11 Fair Wages, Records, Inspection

The Contractor shall pay the labourers engaged by him on the work not less than a fair wage which expression shall mean whether for time or piecework the respective rates of wages as fixed by the Public Works Department as fair wages for Dakshina Kannada District payable to the different categories of labourers of those notified under the Minimum Wages Act.

The Contractor shall maintain records of Wages and other remuneration paid to his employee in such form as may be convenient and to the requirements of the Employer/Engineer and the Labour Enforcement Officer (Central), Ministry of Labour, Govt. of India, or such other authorized person appointed by the Central Govt. The Contractor shall allow inspection of the aforesaid Wage Records and Wage

Slips to the Engineer and to any of his workers or to his agent at a convenient time and place after due notice is received, or to any other person authorized by him on his behalf.

71.12 Reporting of Accidents

The Contractor shall report to the Engineer details of any accident as soon as possible after its occurrence. In the case of any fatality or serious accident, the Contractor shall, in addition, notify the local police authorities immediately by the available means.

71.13 Observance by Sub-Contractors

The Contractor shall be responsible for observance by his sub-contractors of the foregoing provisions.

71.14 Port Entry Permission

The Contractor shall submit prior application for Port entry passes to the concerned Port authority for his Materials, labors and the staffs engaged in the works. The Contractor has to get the vehicle and labor RIFD based passes for the entry inside the wharf area based on prevailing rates.

71.15 Site - Protected Area

The Site of Work is a protected area. Entry to the Port premises is regulated by entry passes. These passes will be issued by the Central Industrial Security Force or any other authority authorized by the Employer. The Contractor should furnish a list of person for whom the passes are to be issued to the Engineer and arrange to obtain the passes from the appropriate authority, based on the recommendation of the Engineer and abide by the Rules of the New Mangalore Port Authority with regard to entry etc. For the entry of trucks and other vehicles also, the Contractor should obtain necessary permits. The Contractor shall retain the original passes obtained by them in respect of their labour and staffs engaged in the Works and produce the same to the Engineer as and when called for. It should not be either destroyed or allowed to be taken by the labour/staff after its use.

72. Life Saving Appliances and First Aid

The Contractor shall provide and maintain upon the Works sufficient proper and efficient life saving appliances and first aid equipment to the approval of the Engineer. The appliances and equipment shall be available for use at all times.

73. Diving Operations (Not Applicable)

- a) Any diving work shall be carried out in accordance with the Diving Operations Regulations of the Government of India.
- b) Before any diving work is undertaken the Contractor shall supply the Engineer or his representative with two copies of the Code of signals to be employed and is to have a copy of such Code Prominently displayed on the craft or structure from which the operations take place

74. Bribes

If the Contractor, or any of his Subcontractors, agents or servants gives or offers to

give to any person any bribe, gift, gratuity or commission as an inducement or reward for doing or forbearing to do any action in relation to the Contract or any other contract with the Employer, or for showing or forbearing to show favour or disfavor to any person in relation to the Contract or to any other contract with the Employer, then the Employer may enter upon the Site and the works and terminate the employment of the Contractor and the provisions of Clause 63 hereof shall apply as if such entry and termination had been made pursuant to that Clause.

The bidders shall give an undertaking that they have not made any payment or illegal gratification to any person/authority connected with the bid process so as to influence the bid process and have not committed any offence under the PC Act in connection with the bid.

75. Details to be Confidential

The Contractor shall treat the details of the contract as private and confidential, save insofar as may be necessary for the purposes thereof, and shall not publish or disclose the same or any particulars thereof in any trade or technical paper or elsewhere without the previous consent in writing of the employer. If any dispute arises as to the necessity of any publication or disclosure for the purpose of the Contract the same shall be referred to the decision of the Employer whose award shall be final.

76. Contractor's Temporary works, office, etc.

76.1 The Contractor shall submit to the Engineer for his approval not less than 15 days before commencement of erection of any part of Temporary Works, drawings and detailed proposals for the method of construction of Temporary works such as office, store, false work and temporary platforms etc. which he intends to construct for the execution of the contract and no such work shall be constructed before obtaining the written approval of Chief Engineer. These temporary works, office, store etc. shall be erected at or near the work area subject to approval of the Employer and the land space for the same will be allotted free of ground rent to the extent available. The Contractor shall obtain permission for any Temporary Works and would ensure that during execution of works the statutory requirements of the concerned authorities such as New Mangalore Port Authority, Police, Customs, etc. would be complied with.

76.2 Submission of Reports, Returns, etc.

All reports, statements, returns, drawings, diagrams etc. which the Contractor is required to submit to the Engineer during the progress of the Works, shall be furnished in triplicate without any additional cost.

77. Water Supply

Water to the extent available will be supplied to the Contractor at a fixed point on the main water supply line within the Port area. The plumbing connection and extension of necessary supply pipeline to the working area shall be arranged by the

Contractor at his own cost. The Contractor shall also provide a water meter at his cost for metering the quantity of water used. Charges for the consumption of the water will be paid by the Contractor to the Employer at notified rate as applicable time to time during the currency of the Contract. For non-supply of water at any stage port will not be responsible and the Contractor shall not have any claim whatever for loss or damage.

78. Power Supply

The Electricity connection for lighting, welding and other mechanical works to the extent available will be made available by the Employer within the Port area. Drawing of power lines etc. from the available point of supply of power to the actual work site either by overhead lines or underground cables shall be arranged by the contractor at his cost. The temporary lines and connections by the Contractor shall be approved by the Engineer's representative before availing power. The Contractor shall provide Trivector Meter to read consumption in units, power demand and power factor.

The Contractor shall indicate his requirement of power to the Engineer within 15 days from the date of the letter of acceptance of the tender. If the power requirement is more than 50 KW, the Contractor has to avail the power supply at 11 KV and install his own transformer of suitable capacity and work carried out as per IE Rules & Regulations as approved by the CEA. The Contractor shall pay to the Employer, the power charges as per the prevailing Tariff schedule of MESCOM in force during the work of the Contractor. At present, it is Rs.7.46 per unit consumed and demand charges @ Rs. 190.00 per KVA or part thereof per month on connected load, security deposit Rs. 4,604.00 per KVA along with departmental charges @ 23.75% of the bill amount. The Contractor shall also pay the connection and disconnection charges as applicable.

The Contractor shall ensure that the power factor of the system does not fall below 0.90 at any time and shall provide at his cost required capacity capacitors bank to maintain the Power Factor of all power loads. If the capacity of the capacitor found less than stipulated as per regulation during inspection, surcharge at Rs. 0.03 per unit will be levied. The contractor shall pay refundable Security Deposit of Rs. 4,604/- per KVA of the sanctioned load, before availing the power supply in the form of a Demand Draft drawn in favour of FA&CAO, NMPA from any Scheduled Bank.

The Contractor shall submit a complete drawing of the power points, wiring, diagram indicating all electrical loads, earthing etc. in complete shape along with the completion report. The Trivector Meter provided is calibrated either by M/s. MESCOM or NITK, Surathkal, and such a Certificate to be produced. For non-supply of power at any stage port will not be responsible and the Contractor shall not have any claim whatever for loss or damage.

79. Taxes and Duties

79.1 The Contractor shall pay Tax if any and other levies as applicable from time to time.

GST at applicable rate shall be shown separate line items in the Tax invoice.

79.2 Sales / Turnover Tax on Works Contract (Deleted)

79.3 Income Tax

The Contractor and his staff shall be responsible for payment of all personal income taxes to the concerned authorities as per the law in force from time to time. Deduction of Income Tax shall be made by the Employer from each certificate of payment to the contractor at the rate of 2% plus surcharge or such other rates as may be specified by the Central Government from time to time, on the gross amount of the Contractor's bill for payment.

79.4 Goods and Service tax

The contractor shall not include GST component in rate. The GST shall be paid to the contractor separately as applicable. The contractor shall submit running account bills indicating GST separately as applicable. The Contractor shall be responsible for the payment of GST applicable, to the GST authority. The contractor shall file the applicable returns with tax department in time and submit the same as documentary evidence.

The invoice with respect to supplies should contain following information:-

- Name of the Customer : New Mangalore Port Authority
- GSTIN of the Customer : 29AAALN0057A2ZG
- All other information as specified in GST act and GST tax invoice rules such as SAC code, Supplier address, Supplier GSTIN, IRN number QR code etc.

Noncompliance of the above result in rejection of invoice.

The Invoice should be uploaded to GST website on monthly basis with in the due date as specified by GST act. Input tax credit lost by Port due to any error, omission or non filing of return will be recovered from any amount due to the supplier Any input tax credit lost by the Port due to due to any error, omission or non filing of return will be recovered from the bills and other monies available with the Port

80. Price Adjustment (not applicable to this contract)

81. Noise and Disturbance

All works shall be carried out without unreasonable noise and disturbance. The Contractor shall indemnify the Employer from and against any liability for damages on account of noise or other disturbance created while or in carrying out the work and from and against all claims demands proceedings damages costs charges and expenses whatsoever in regard or in relation to such liability.

82. Safety Code

Necessary Indian Safety regulations for the safety purpose shall be adhered to by the contractor and he will be held responsible for any violations of the same. The set of such conditions (regulation) is available with NMPA and the contractor is required to go through it before tendering.

Besides the above, the Contractor shall also scrupulously adhere to and observe the following safety codes:

The Contractor has to provide sufficient barricades to site of work so that traffic

plying nearby should not damage the recently concreted work. In case of any damage on account of above, the entire responsibility will remain with contractor and nothing extra will be paid on this account.

Suitable and strong scaffolds should be provided for the workmen for all work that cannot be safely done from ground. No portable single ladder shall be over 8 meters in length.

Hoisting machines and tackles used in the works including their attachments, and supports shall be in perfect condition as per stipulations of the relevant Rules. The ropes used for hoisting or lowering materials or as means or

suspension shall be of durable quality and adequate strength and free from defects. The excavated material shall not be placed within 1.5 meters of the edge of the trench or half of the depth of the trench, whichever is more. All trenches and excavation shall be provided with necessary fencing to lighting. Every opening in the floor of a building or in a working platform shall be provided with suitable fence to prevent the fall of persons or materials. No floor, roof or other parts of the structure shall be so overloaded with debris or materials as to render it unsafe.

Workers employed on mixing and handling materials such as cement, cement mortar, concrete, lime mortar and asphalt shall be provided with protective footwear and rubber hand gloves and thin cloth for covering face and head.

Those engaged in welding work shall be provided with welder protective eye shield and glove.

All safety rules shall be strictly followed while working on live electrical systems or installations as stipulated in the relevant Rules.

83. Port Authority Rules

The Contractor shall observe the Conservancy Rules relating to the harbour and shall always take such necessary additional steps to keep the harbour waters free of noxious or unhygienic matters coming from his works as are required by the Employer. Under no circumstances shall inflammable materials be allowed to spill into the harbour waters.

The Contractor shall always observe and comply with the working rules and regulations of the Port Authority in force or as issued from time to time.

84. Execution of work

The contractor shall be required to execute the work in such a way so as not to cause any damage, hindrance or interference with port activities going on in the area or nearby. He should not also deposit the materials at such places which may cause inconvenience to the public and the work going on in the nearby area. The Contractor shall have to make good all damages done by him to the structures nearby while executing the work and no extra payment shall be made to him on that account.

All the materials required to be used in the work shall have to be got approved from the Engineer-in-Charge before stacking at the site of work.

Barricading, including proper lighting arrangement in the night at the required places shall have to be provided by the contractor at his own cost, including necessary arrangements for proper movement of traffic by carefully maintained approaches and road diversions with suitable sign boards for indications of road signs etc. as directed by the Engineer-in-Charge.

85. Customs Duty

Being Port Development Project, Customs Duty shall be applicable as per project import chapter 9801.00 read with Notification 17-2001, serial No. 38 (vi) and Notification 42-96 amended by 21-2000 of customs tariff, Government of India.

Customs Duty leviable shall be paid directly by the Contractor to the Customs Authorities, Government of India. The Employer shall reimburse this amount upon submission of documentary evidence in original for the proof of payment of such Customs Duty. The reimbursement of such amount towards Customs Duty shall be limited to the Ceiling amount quoted by the Contractor in the Bill of Quantities as above. If the Contractor incurs Customs Duty Levy less than the said Ceiling Amount, the reimbursement by the Employer shall be limited to the documented cost of Customs Duty levies actually paid to the Customs Authorities, Government of India. If the Actual Customs Duty levies paid by the Contractor exceeds the said Ceiling Amount, then the reimbursement by the Employer shall be limited to the Ceiling Amount. The reimbursement of the Customs Duty will be limited only to the Imported Materials listed in "Preamble and Bill of Quantities", BOQ No. __. During the execution of the Works, if it necessitates for expeditious completion of the Works, Contractor may resort to import of any of the materials not listed aforesaid, with the approval of the Employer. However, the aggregate amount of Customs Duty to be reimbursed shall not exceed the lump sum amount offered in the Priced Bill of Quantities.

It shall be the responsibility of the Contractor to provide the requisite particulars and documents to the customs and other Government authorities and get the Imported Materials cleared and transported in time. The Contractor shall be fully responsible for port and Customs clearance including stevedoring, handling, unloading, loading, storage, inland transportation, if any of materials, equipments and plant to storage godowns, yards, sites etc. The contractor shall be fully responsible for any delays, penalties charges and losses if any in this regard.

The Employer shall upon request from the Contractor along with necessary details, provide recommendatory letter(s) for Imported Materials at concession rate or Customs Duty as applicable. However, the responsibility for obtaining such concession rate of customs duty shall be that of the Contractor.

It shall be the responsibility of the Contractor to check the latest position on Customs duty levies applicable and the Employer does not accept any liability on the account. For bill of Lading, the "Consignee" for permanent materials to

be incorporated into the Works will be the New Mangalore Port Authority. The Contractor will be "Notify Party". Notwithstanding the above, obtaining "Essentiality Certificate" (if any), payment of deposit (if any) towards Customs Duty, etc. shall be the responsibility of the Contractor.

The Contractor shall give an undertaking follows:

- a) Being the ultimate Employer of the materials to be imported and incorporated into the works covered under the Tender _____ we request New Mangalore Port Authority to be consignee in the matter of permanent materials to be imported by us at our cost (covering payments of materials by letter of credit) including freight, insurances, taxes and any other charges whatsoever payable in connection with the import and its incorporation into the work.
- b) We hereby confirm, in the event of New Mangalore Port Authority becoming consignee, it will not absolve us from any of the obligations, and will not alter the payment terms under the Contract No. SCB II/ 2009 dated between (*the Contractor*) and New Mangalore Port Authority.
- c) New Mangalore Port Authority becoming a consignee is a matter of convenience and we undertake to abide by all the obligations, responsibilities etc. as if we are our self a consignee.
- d) In respect of nay consequences arising out of New Mangalore Port Authority becoming the consignee we hereby unequivocally and irrevocably agree to indemnify New Mangalore Port Authority for such consequences.
- e) We also undertake and confirm to obtained all permits and licenses etc. at our own cost. New Mangalore Port Authority's responsibilities in this regard will be the same as under the said contract and limited to issuing required recommendatory letters for obtaining such permits and licenses.
- f) *This undertaking does not in anyway vitiate our contractual liabilities and obligations cast upon us by Contract No. _____ / 20XX dated between(the Contractor) and New Mangalore Port Authority.*

86. Drawings & Designs

- (a) General details of the works are shown on the drawings accompanying this tender document. The Engineer will supply to the Contractor from time to time during the progress of the works such further working drawings as will be necessary in his opinion for the proper and adequate execution and maintenance of the Works in accordance with the Engineer's designs and/or any modification thereof as decided by the Engineer and the Contractor shall carry out the work in accordance with the said working drawings. Two sets of such working drawings will be issued. If the Contractor requires more sets he will have to make his own arrangement at his cost. Residual Design, Detailing & Engineering: - The Engineer to the project has done the

detailed design and engineering for the subject tender. During execution of the work the residual design, detailing and engineering, if needed, is to be carried out by the contractor at no extra cost to the Employer. For equipment/ Installations detailed drawings need to be produced by the contractor at no extra cost to the Employer. The contractor shall also get approved such design, detailing & engineering from the Engineer.

- (b) In the event of the Contractor proposing any alteration/modification to the Engineer's design, detail, method of construction, he shall at his own expenses prepare and submit for approval of the Engineer copies in duplicate (in the first instance) of detailed working drawings which may be required for such alteration/modification and at the same time call the attention of the Engineer to any alternative detail or modification of the contract drawings which the Contractor may wish to make at least 30 days prior to the commencement of the work or part of the work to which such drawings relate. The contractor shall at the same time, if so required by the Engineer, furnish calculation sheets in duplicate relating to the strength and anticipated deflections in respect of such altered/modified works. The Engineer will, after any such alteration which he may approve, record on the copies as amended his approval and will return one copy of the drawings and calculation sheets to the contractor, who shall carry out the work in accordance therewith. The contractor shall forward to the Engineer three additional copies of the working drawings and calculation sheets as approved in addition to these working drawings and calculation sheets as approved. In addition to these working drawings are also to be submitted (the same procedure as in the case of the contractor) in respect of any work proposed to be executed by sub-contractors. The approval of the Engineer of all or any of the calculation sheets, drawings shall not relieve the contractor of responsibility in connection with the execution of the altered/modified or subcontractor's work.

- (c) Submission of 'As built Drawings'

"As built" Drawings are required to be submitted by the Contractor and shall be supplied by them by the dates stated in the Contract Data. If the Contractor does not supply the Drawings and/or manuals by the dates stated in the Contract Data, or they do not receive the Engineer or his nominee's approval, the Engineer or his nominee shall withhold the amount stated in the Contract Data from payments due to the Contractor.

87. Monsoon Period

Monsoon period will be reckoned from 1st June to 30th September.

88. Progress Report

The following reports shall be submitted for review; as an input to the Management meeting to be held as per Clause No 31 of Conditions of Contract.

88.1 Daily reports

The contractor shall submit daily report indicating daily activities, weather condition, actual manpower, equipment and the prominent materials available and arriving to site. The contractor shall submit the daily report format to the Department for prior approval.

88.2 Monthly Reports

Monthly progress reports shall be prepared by the Contractor and submitted to the Engineer in triplicate. The first report shall cover the period up to the end of the first calendar month following the Commencement Date. Reports shall be submitted monthly thereafter, each within 7days after the last day of the period to which it relates. Reporting shall continue until the Contractor has completed all work, which is known to be outstanding at the completion date, stated in the Taking-Over Certificate for the Works.

Each report shall include:

- a) Charts and detailed descriptions of progress, including each stage of design (if any), Contractor's Documents, procurement, manufacture, delivery to Site, construction, erection and testing; and including these stages for work by each Sub-Contractor,
- b) Photographs in hardcopy & digital copy and videography in two sets showing the various stages of progress on the Site monthly;
- c) For the supply of manufactured items, the name of the manufacturer, manufacture location, percentage progress, and the actual or expected dates of:
 - i) Commencement of manufacture,
 - ii) Contractor's/Engineer's inspections,
 - iii) Tests,
 - iv) Shipment and arrival at the Site;
- d) Copies of quality assurance documents, test results and certificates of Materials;
- e) Safety statistics, including details of any hazardous incidents and activities relating to environmental aspects and public relations; and
- f) Comparisons of actual and planned progress, with details of any events or circumstances which may jeopardize the completion In accordance with the Contract, and the measures being (or to be) adopted to overcome delays.

89. Completion Documents (not applicable)

To treat that the work has been completed and issue a final payment certificate, the following documents will be deemed to form the completion documents:

- i) The Technical documents according to which the work was carried out.
- ii) The set of construction drawings showing therein the modifications and corrections made during the course of execution signed by the Engineer.
- iii) Certificates of final levels and dimensions as set out for various works.
- iv) Certificates of tests performed for various works.
- v) "As Built" Drawings.

90. Submission of statutory documents

The successful bidder, with in 7days from the date of work order, shall submit self-attested copy of statutory documents such PAN card, GST registration certificate, ESI registration certificate, EPF registration certificate, Labour Identification Number (LIN) and any other documents required for successful completion of work.

G. SALIENT FEATURES OF SOME MAJOR LAWS APPLICABLE TO ESTABLISHMENTS ENGAGED IN CONSTRUCTION WORK

- (a) Workmen Compensation Act 1923:- The Act provides for compensation in case of injury by accident arising out of and during the course of employment.
- b) Payment of Gratuity Act 1972: Gratuity is payable to an employee under the Act on satisfaction of certain conditions on separation if an employee has completed 5 years service or more on death at the rate of 15 days wages for every completed year of service. The Act is applicable to all establishments employing 10 or more employees.
- (c) Employees P.F and Miscellaneous Provision Act 1952: The Act Provides for monthly contributions by the employer and workers @ 13.00% and 12% respectively. The benefits payable under the Act are:
 - (i) Pension to family pension on retirement or death, as the case may be.
 - (ii) Deposit linked insurance on the death in harness of the worker.
 - (iii) Payment of P.F accumulation on retirement/death etc.
- d) Maternity Benefit Act 1951:-The Act provides for leave and some other benefits to workmen/ employees in case of confinement or miscarriage etc.
- e) Contract Labour (Regulation & Abolition) Act 1970:-The Act provides for certain welfare measures to be provided by the Contractor to contract labour and in case the Contractor fails to provide, the same are required to be provided, by the Principal Employer by Law. The Principal Employer is required to- take Certificate of Registration and the Contractor is required to take license from the designated Officer. The Act is applicable to the establishments or Contractor of Principal Employer if they employ 20 or more contract labor.
- f) Minimum Wages Act 1948: The Employer is supposed to pay not less than the Minimum Wages fixed by appropriate Government as per provisions of the Act if the employment is a scheduled employment Construction of Buildings, Roads, Runways are scheduled employment.
- (g) Payment of Wages Act 1936:-It lays down as to by what date the wages are to be paid when it will be paid and what deductions can be made from the wages of the workers.
- (h) Equal Remuneration Act 1979:-The Act provides for payment of equal wages for work of equal nature to Male and Female workers and for not making discrimination against Female employees in the matters of transfers, training and promotions etc.
- i) Payment of Bonus Act 1965: The Act is applicable to all establishments employing

20 or more employees. The Act provides for payments of annual bonus subject to a minimum of 8.33% of wages and maximum of 20% of wages to employees drawing Rs.3,500/- per month or less. The bonus to be paid to employees getting Rs.2,500/- per month or above up to Rs.3,500/- per month shall be worked out by taking wages as Rs.2,500/- per month only. The Act does not apply to certain establishments. The newly set-up establishments are exempted for five years in certain circumstances. Some of the State Governments have reduced the employment size from 20 to 10 for the purpose of applicability of this Act.

- j) Inter-State Migrant workmen's (Regulation of Employment & Conditions of Service) Act 1979: The Act is applicable to an establishment which employs 5 or more inter-state migrant workmen through an intermediary (who has recruited workmen in one state for employment in the establishment situated in another state). The Inter-State migrant workmen, in establishment to which this Act becomes applicable, are required to be provided certain facilities such as housing, medical aid, travelling expenses from home upon the establishment and back,
- k) The Building and Other Construction workers (Regulation of Employment and Conditions of Service) Act 1996 and the Cess Act of 1996:- All the establishments who carry on any building or other construction work and employs 10 or more workers are covered under this Act. All such establishments are required to pay cess at the rate not exceeding 2% of the cost of construction as may be modified by the Government. The Employer of the establishment is required to provide safety measures at the Building or Construction work and other welfare measures, such as Canteens, First-Aid facilities. Ambulance, Housing accommodations for workers near the work place etc. The Employer to whom the Act applies has to obtain a registration certificate from the Registering Officer appointed by the Government.

v) CONTRACT DATA

Items marked "N/A" do not apply in this Contract.

Sl. No.	Description	Reference Cl. No.
1	The following documents are also part of the Contract	
	The Schedule of other contractors	(8)
	The Schedule of Key personnel	(9)
2	The above insertions should correspond to the information provided in the Invitation of Bids.	
3	The Employer is	(1)
	New Mangalore Port Authority, Panambur, Mangalore - 575010	
	Name of Authorized Representative:	
	Name : Chairman, New Mangalore Port Authority, Panambur, Mangalore - 575010	
4	The Engineer is	
	Name : Chief Engineer (C), New Mangalore Port Authority, Panambur, Mangalore- 575010	
	Name of Nominee is	
	Name : Superintending Engineer (C-II) Civil Engineering Department, NMPA, Panambur, Mangalore- 575010	
5	The name and identification number of the Contract is	
	Name of Contract:- "Supply and Installation of flag mast near entrance gate at NMPA" Tender no: 05/2023-24	(1)
6	The works consist of "Supply and Installation of flag mast near entrance gate at NMPA".	(1)

Sl. No.	Description	Reference Cl. No.						
7	<p>Schedule date of commencement 7 days from the date of Issue of Letter of Acceptance.</p> <p>However No work shall be commenced before signing of contract Agreement.</p>	<p>Conditions of contract A-General 1.Definitions 59.2(a)</p>						
8	<p>The Contract price is the price stated in the letter of acceptance. However payment will be made as per actual work done accordance with the contract provisions.</p>	1.Definitions						
9	<p>The Intended completion Date for the whole of the Work is 3 (Three) Months (including monsoon) with the following milestones:</p>	(17,27)						
10	<table border="1" style="width: 100%; border-collapse: collapse;"> <tr> <td colspan="2" data-bbox="391 783 1190 814">Milestone dates:</td> </tr> <tr> <td data-bbox="391 814 792 888">Physical works to be completed</td> <td data-bbox="792 814 1190 888">Period from the date of commencement of work</td> </tr> <tr> <td colspan="2" data-bbox="391 888 1190 993">Milestones dates shall be provided to the Contractor by the Executive Engineer executing the work for completion of the work as per the scheduled date.</td> </tr> </table>	Milestone dates:		Physical works to be completed	Period from the date of commencement of work	Milestones dates shall be provided to the Contractor by the Executive Engineer executing the work for completion of the work as per the scheduled date.		(27)
Milestone dates:								
Physical works to be completed	Period from the date of commencement of work							
Milestones dates shall be provided to the Contractor by the Executive Engineer executing the work for completion of the work as per the scheduled date.								
11	<p>The following shall form part of the Contract Document:</p> <ol style="list-style-type: none"> (1) Form of Agreement (2) Letter of Acceptance (3) Contractor's Bid (4) Contract Data (5) Conditions of Contract including Special Conditions of Contract (6) Specifications (7) Drawings (8) Bill of quantities and (9) Any other documents listed in the Contract Data as forming part of the Contract. (10) Correspondence exchanged after the opening of the Bid and before the issue of Letter of Acceptance by which the Condition of Contract are amended, varied or modified in any way by mutual consent (to be enumerated). 	(2.3)						
12	<p>The Contractor shall submit a Program for the Works within 14 days of delivery of the letter of Acceptance.</p>	(27)						
13	<p>The site possession date The site will be handed over immediately after issue of Letter of acceptance and the site is free from</p>	(21)						

Sl. No.	Description	Reference Cl. No.
	encumbrances.	
14	The site is defined in drawing No. 22/105-LP	
15	The Defects Liability Period is 1 (One) year	(35)
16	The minimum insurance cover for physical property, injury and death is Rs. 5,00,000/- (Rupees five Lakhs) per occurrence with the number of occurrences limited to four. After each occurrence, contractor will pay additional premium necessary to make insurance valid for four occurrences always.	(13)
17	The following events shall also be Compensation Events: The Employer terminates the contract for his convenience.	(44)
18	The period between Programme updates shall be 30 days.	(27)
19	The amount to be withheld for late submission of an updated Programme shall be Rs. 25,000/-.	(27)
20	The Penalty for the delay in submission of the Performance guarantee shall be at the rate of 0.25% of the amount of performance guarantee for each week or part of the week for the number of weeks delayed beyond the stipulated date of submission.	(52.2) 34.1
21	The language of the Contract documents is English.	(3)
22	The law, which applies to the Contract, is the law of Union of India.	(3)
23	The currency of the Contract is Indian Rupees.	(46)
24	Fees and types of reimbursable expenses to be paid to the Dispute Review Board (Deleted) As per actuals and equally shared by both the parties. (NA)	(25)
25	The Dispute Review Board shall be constituted after signing of the agreement on mutually agreed terms. (Appendix 1). (Deleted) (NA)	(25)
26	Price Adjustment (deleted)	(47) (80)
27	The proportion of payments retained (retention money) shall be 10% of total tax invoice value from each bill subject to a maximum of 5% of the contract price including GST as applicable.	(48)
28	The maximum amount of liquidated damages for the whole of the works is 10 % of the contract price plus taxes and	[49]

Sl. No.	Description	Reference Cl. No.
	duties. The half per cent (½%) per week L.D is applicable for delay period of $\frac{1}{3}$ of contract period and thereafter 10% L.D is applicable.	
29	Clause No. 49A (v) deleted.	
30	Advance payment is not applicable to this contract	[51]
31	Repayment of secured advance: deleted	(51.6)
32	The Securities shall be for the following minimum amounts equivalent as a percentage of the Contract Price.	(52)
33	Performance Security in the form of Bank guarantee for 5% of the contract price including GST.	(52.2)
34	The standard form of Performance Security acceptable to the Employer shall be an unconditional Bank Guarantee of the type as presented in Section III (iv) of the Bidding Documents.	Annexure-A
35	The Contractor has to submit the final claim for reimbursement of ESI and EPF contribution on the part of the employer in respect of this contract within 60 days from the date of completion of work.	(71)

vi) FORM OF SECURITIES

Acceptable forms of securities are annexed. Bidders should not complete the Performance Security form at this time. Only the successful Bidder will be required to provide Performance and Advance Payment Securities in accordance with one of the forms, or in a similar form acceptable to the Employer.

Annexure A: Performance Bank Guarantee

Annexure B: Bank Guarantee for Advance Payment

Annexure A

PERFORMANCE BANK GUARANTEE

To: _____ [name of Employer]
_____ [address of Employer]

WHEREAS _____ [name and address of Contractor] (hereinafter called "the Contractor") has undertaken, in pursuance of Contract _____ No. _____ dated _____ to execute _____ [name of Contract and brief description of Works] (hereinafter called "the Contract").

AND WHEREAS it has been stipulated by you in the said Contract that the Contractor shall furnish you with a Bank Guarantee by a recognized bank for the sum specified therein as security for compliance with his obligations in accordance with the Contract;

AND WHEREAS we have agreed to give the Contractor such a Bank Guarantee;

NOW THEREFORE we hereby affirm that we are the Guarantor and responsible to you, on behalf of the Contractor, up to a total of _____ [amount of guarantee]1

_____ [In words], such sum being payable in the types and proportions of currencies in which the Contract Price is payable, and we undertake to pay you, upon your first written demand, and without cavil or argument, any sum or sums within the limits of _____ [amount of guarantee]1 as aforesaid without your needing to prove or to show grounds or reasons for your demand for the sum specified therein.

We hereby waive the necessity of your demanding the said debt from the Contractor before presenting us with the demand.

We further agree that no change or addition to or other modification of the terms of the Contract or of the Works to be performed there under or of any of the Contract documents which may be made between you and the Contractor shall in any way release us from any liability under this guarantee, and we hereby waive notice of any such change, addition or modification.

This guarantee shall be valid until 28 days from the date of expiry of the Defects Liability Period.

Notwithstanding anything mentioned above,

Our liability against this guarantee is restricted to Rs..... (Rupees only) and unless a claim in writing is lodged with us within 3 months of the date of expiry or the extended date of expiry of this guarantee all our liabilities under this guarantee shall stand discharges.

IN WITNESS WHEREOF this guarantee has been duly executed on this day

of

Signature and seal of the guarantor _____

Name of Bank _____

Address _____ Date _____

1An amount shall be inserted by the Guarantor, representing the percentage of the Contract Price specified in the Contract and denominated in Indian Rupees.

Annexure B (NA)

BANK GUARANTEE FOR ADVANCE PAYMENT (NOT APPLICABLE)

To: _____ [name of Employer]
_____ [address of Employer]
_____ [name of Contract]

Gentlemen:

In accordance with the provisions of the Conditions of Contract, Sub-clause 51.1 ("Advance Payment") of the above mentioned Contract, _____ [name and address of Contractor] (hereinafter called "the Contractor") shall deposit with _____ [name of Employer] a bank guarantee to guarantee his proper and faithful performance under the said Clause of the Contract in an amount of

1
_____ [amount of guarantee] _____ [in words].

We, the _____ [bank or financial institution], as instructed by the Contractor, agree unconditionally and irrevocably to guarantee as primary obligator and not as Surety merely, the payment to _____ [name of Employer] on his first demand without whatsoever right of objection on our part and without his first claim to the Contractor, in the amount not exceeding _____ [amount of guarantee]1 _____ [in words].

We further agree that no change or addition to or other modification of the terms of the Contract or of Works to be performed there under or of any of the Contract documents which may be made between _____ [name of Employer] and the Contractor, shall in any way release us from any liability under this guarantee, and we hereby waive notice of any such change, addition or modification.

The guarantee shall remain valid and in full effect from the date of the advance payment under the Contract until _____ [name of Employer] receives full repayment of the same amount from the Contractor.

Notwithstanding anything mentioned above,

Our liability against this guarantee is restricted to Rs.....(Rupeesonly) and unless a claim in writing is lodged with us within 3 months of the date of expiry or the extended date of expiry of this guarantee all our liabilities under this guarantee shall stand discharges.

IN WITNESS WHEREOF this guarantee has been duly executed on thisday of

Yours truly,

Signature and seal: _____

Name of Bank/Financial Institution: _____

Address: _____

Date: _____ 1. An amount shall be inserted by the bank or financial institution representing the amount of the Advance Payment, and denominated in Indian Rupees.

Annexure – C (NA)**BANK GUARANTEE FOR RETENTION MONEY (NOT APPLICABLE)**

To,

New Mangalore Port Authority,
Administrative Building,
Panambur,
Mangalore – 575 010.

1. In consideration of the Board Members of the New Mangalore Port Authority, Mangalore (hereinafter called "The Board" having agreed to refund _____ (hereinafter called "the said contractor(s)") under the terms and conditions of an Agreement No. _____ made between New Mangalore Port Authority and _____ (hereinafter called "the said Agreement") the retention money for the due fulfillment by the said contractor(s) of the terms and conditions contained in the said agreement on production of a bank guarantee for _____. We _____ (hereinafter referred to as "the Bank") at the request of M/s. _____ do hereby undertake to pay the Board an amount not exceeding _____ on demand.
2. We _____ do hereby undertake to pay the amounts due and payable under this guarantee without any demur, merely on a demand from the Board stating that the amount claimed is required to meet the recoveries due or likely to be due from the said Contractor(s). Any such demand made on the bank shall be conclusive as regards the amount due and payable by the Bank under this guarantee. However, our liability under this guarantee shall be restricted to an amount _____ not exceeding Rs. _____
3. We _____ undertake to pay the Board any money so demanded notwithstanding any dispute or disputes raised by the Contractor(s) in any suit or proceeding pending before any Court or Tribunal relating there to, our liability under this present being absolute and unequivocal.
The payment so made by us under this bond shall be a valid discharge of our liability for payment there under and the Contractor(s) shall have no claim against us for making such payment.
4. We _____ further agree that the guarantee herein contained shall remain in full force and effect during the period that would be taken for the performance of the said Agreement and that it shall continue to be enforceable till all the dues of the Board under or by virtue of the said Agreement have been fully paid and its claims satisfied or discharged or till Engineer-in-charge on behalf of the

Board certifies that the terms and conditions of the said Agreement have been fully and properly carried out by the said Contractor(s) and accordingly discharges this guarantee.

5. We _____ further agree with the Board that Board shall have the fullest liberty without our consent and without affecting in any manner our obligations here under to vary any of the terms and conditions of the said agreement or to extend time of performance by the said Contractor(s) from time to time or to postpone for any time or from time to time any of the powers exercisable by the Board against the said Contractor(s) and to forbear or enforce any of the terms and conditions relating to the said Agreement and we shall not be relieved from our liability by reason of any such variation, or extension being granted to the said Contractor(s) or for any forbearance act or omission on the part of the Board or any indulgence by the Board to the said Contractor(s) or by any such matter or thing whatsoever which under the law relating to sureties would but for this provision, have effect so relieving us.
6. This guarantee will not be discharged due to the change in the constitution of the Bank or the Contractor(s).
7. We _____ lastly undertake not to revoke this guarantee except with the previous consent of the Board in writing.
8. This guarantee shall be valid up to _____ unless extended on demand by Board Notwithstanding anything mentioned above, our liability against this guarantee is restricted to Rs. _____ and unless a claim in writing is lodged with us within three months of the date of expiry or such extended date of expiry of this guarantee all our liabilities under this guarantee shall stand discharged.

Notwithstanding anything contained herein.

1. Our liability under this Bank Guarantee restricted to a sum of Rs. _____ Only).
2. This bank guarantee shall be valid up to _____ We are liable to pay the guaranteed amount or any part thereof under this bank guarantee only and only if you serve upon us a written claim or demand on or before _____.

APPENDIX 1 TO GENERAL CONDITIONS OF CONTRACT (NA)

DISPUTES REVIEW BOARD AGREEMENT (NOT APPLICABLE)

THIS AGREEMENT, made and entered into this Day of.....20..... Between ("the Employer") and..... ("the Contractor"), and the Disputes Review Board ("the Board") consisting of One / three Board Members, (1) (2) (3)

[Note : Delete whatever is not applicable]

WITNESSETH, that

WHEREAS, the Employer and the Contractor have contracted for the construction of the

..... (Project name) (the "Contract") and

WHEREAS, the contract provides for the establishment and operation of the Board NOW THEREFORE, the parties hereto agree as follows :

- 1. The parties agree to the establishment and operation of the Board in accordance with this Board Agreement.
- 2. Except for providing the services required hereunder, the Board Members should not give any advice to either party or to the Engineer or his nominee concerning conduct of the Works.

The Board Members :

- a. shall have no financial interest in any party to the contract or the Engineer or his nominee, or a financial interest in the contract, except for payment for services on the Board.
- b. shall have had no previous employment by, or financial ties to, any party to the contract, or the Engineer or his nominee, except for fee based consulting services on other projects, all of which must be disclosed prior to appointment to the Board.
- c. shall have disclosed in writing to the parties prior to signature of this Agreement any and all recent or close professional or personal or personal relationships with any director, officer, or employee of any party to the contract, or the Engineer or his nominee, and any and all prior involvement in the project to which the contract

relates;

- d. shall not, while a Board Member, be employed whether as a consultant or otherwise by either party to the contract, or the Engineer or his nominee, except as a Board Member.
 - e. shall not, while a Board Member, engage in discussion or make any agreement with any party to the contract, or with the Engineer or his nominee, regarding employment whether as a consultant or otherwise either after the contract is completed or after services as a Board Member is completed;
 - f. shall be and remain impartial and independent of the parties and shall disclose in writing to the Employer, the Contractor, the Engineer or his nominee, and one another any fact or circumstances which might be such to cause either the Employer or the Contractor to question the continued existence of the impartiality and independence required of Board Members.
3. Except for its participation in the Board's activities as provided in the contract and in this Agreement none of the Employer, the Contractor, the Engineer or his nominee, and one another any fact or circumstances which might be such to cause either the Employer or the Contractor to question the continued existence of the impartiality and independence required of Board Members.
 4. The Contractor shall :
 - a) furnish to each Board Members one copy of all documents which the Board may request including contract documents, progress reports, variation orders, and other documents, pertinent to the performance of the Contract.
 - b) in co-operation with the Employer, co-ordinate the Site visits of the Board, including conference facilities, and secretarial and copying services.
 5. The Board shall serve throughout the operation of the contract. It shall begin operation following execution of this Agreement, and shall terminate its activities after issuance of the taking over Certificate and the Board's issuance of its Recommendations on all disputes referred to it.
 6. Board Member shall not assign or subcontract any of their work under this Agreement.
 7. The Board Members are independent and not employees or agents of either the Employer or the Contractor.
 8. The Board Members are absolved of any personal or professional liability arising from the activities and the Recommendations of the Board.
 9. Fees and expenses of the Board Member[s] shall be agreed to and shared equally by

the Employer and the Contractor. If the Board requires special services, such as accounting, data research, and the like, both parties must agree and the costs shall be shared by them as mutually agreed.

10. Board Site visits :

- a. The Board shall visit the Site and meet with representatives of the Employer and the Contractor and the Engineer or his nominee at regular intervals, at times of critical construction events, and at the written request of either party. The timing of Site failing agreement shall be fixed by the Board.
- b. Site meetings shall consist of an informal discussion of the status of the construction of the works followed by an inspection of the works, both attended by personnel from the Employer, the Contractor and the Engineer or his nominee.
- c. If requested by either party or the Board, the Employer will prepare minutes of the meetings and circulate them for comments of the parties and the Engineer or his nominee.

11. Procedure for disputes referred to the Board:

- a. If either party objects to any action or inaction of the other party or the Engineer or his nominee, the objecting party may file a written Notice of Dispute to the other party with a copy to the Engineer or his nominee stating that it is given pursuant to Clause 65 and stating clearly and in detail the basis of the dispute.
- b. The party receiving the Notice of Dispute will consider it and respond in writing within 7 days after receipt.
- c. This response shall be final and conclusive on the subject, unless a written appeal to the response is filed with the responding party within 7 days of receiving the response. Both parties are encouraged to pursue the matter further to attempt to settle the dispute. When it appears that the dispute cannot be resolved without the assistance of the Board either party may refer the dispute to the Board by written Request for Recommendation to the Board, the other party and the Engineer or his nominee stating that it is made pursuant to Clause 65.
- d. The Request for recommendation shall state clearly and in full detail the specific issues of the dispute to be considered by the Board.
- e. When a dispute is referred to the Board, and the Board is satisfied that the dispute requires the Board's assistance, the Board shall decide when to conduct a hearing on the dispute. The Board may request that written documentation and arguments from both parties be submitted to each Board Members before the hearing begins. The parties shall submit insofar as possible agreed statements of the relevant facts.
- f. During the hearing, the Contractor, the Employer, and the Engineer or his nominee shall each have ample opportunity to be heard and to offer evidence. The Board's Recommendations for resolution of the dispute will be given in writing, to the Employer, the Contractor and the Engineer or his nominee as soon as possible, and

in any event not more than 28 days after the Board's final hearing on the dispute.

12. Conduct of Hearings :

- a. Normally hearing will be conducted at the Site, but any location that would be more convenient and still provide all required facilities and access to necessary documentation may be utilised by the Board. Private sessions of the Board may be held at any location convenient to the Board.
- b. The Employer, the Engineer or his nominee and the Contractor shall have representatives at all hearings.
- c. During the hearings, no Board Member shall express any opinion concerning the merit of any facet of the case.
- d. After the hearing are concluded, the Board shall meet privately to formulate its Recommendations. All Board deliberations shall be conducted in private, with all individual views kept strictly confidential. The Board's Recommendations, together with an explanation of its reasoning shall be submitted in writing to both parties and to the Engineer or his nominee. The Recommendations shall be based on the pertinent contract provisions, applicable laws and regulations, and the facts and circumstances involved in the dispute.
- e. The Board shall make every effort to reach a unanimous Recommendation. If this proves impossible, the majority shall decide, and the dissenting member any prepare a written minority report for submission to both parties.

[Note : Delete if it is one member Board]

13. If during the contract period, the Employer and the Contractor are of the opinion that the Dispute Review Board is not performing its functions properly; the Employer and the Contractor may together disband the Disputes Review Board. In such an event, the disputes shall referred to Arbitration straightaway.

The Employer and the Contractor shall jointly sign a notice specifying that the Board shall stand disbanded with effect from the date specified in the notice. The notice shall be posted by a registered letter with AD or delivery of the letter, even if he refuses to do so.



**NEW MANGALORE PORT AUTHORITY
PANAMBUR, MANGALORE**

**"SUPPLY AND INSTALLATION OF FLAG MAST
NEAR ENTRANCE GATE AT NMPA"**

**TENDER DOCUMENT
VOLUME - II**

NEW MANGALORE PORT AUTHORITY
CIVIL ENGINEERING DEPARTMENT
TENDER NO: CIVIL/CE(C)/EE(C)/05/2023-24
TENDER FOR

“Supply and Installation of flag mast near entrance gate at NMPA”

<u>Volume</u>	Section I	i) Notice Inviting Tenders
<u>I</u>		ii) Instructions to Tenderers
		ii) Annexure (1 to 13)
	Section II	i) Form of Agreement
	Section III	i) Conditions of Contract: Part A - E: General Conditions
		ii) Conditions of Contract : Part F: Special Conditions
		iii) Contract Data
		iv) Form of Securities (A & B)
		v) Appendix – I and Appendix - II
<u>Volume</u>	Section IV	i) Technical Specifications
<u>II</u>		
	Section V	ii) Drawings
<u>Volume</u>	Section VI	i) Preamble
<u>III</u>		ii) Bill of Quantities
		iii) For of tender
	Section VII	i) Schedules (A & B)

Table of Contents

TECHNICAL SPECIFICATIONS		109
A.	GENERAL.....	109
1.	INTRODUCTION.....	109
B.	Works	113
1.	Clearing and grubbing road land.....	113
2.	DISMANTLING AND DEMOLISHING	115
3.	Earth work excavation by manual means	122
4.	Earth work excavation by manual means	139
5.	Dismantling steel work in built up sections.....	140
6.	Providing and Filling in foundation with granite.....	140
7.	Providing and laying in position plain cement concrete.....	140
8.	Providing and constructing laterite size stone masonry	140
9.	Providing and constructing laterite size stone masonry	140
10.	Providing and laying in position plain cement concrete.....	140
11.	Providing Thermo-Mechanically Treated bars.....	141
12.	Providing and laying in position Reinforced cement concrete	141
13.	Filling available excavated earth.....	141
14.	Providing cement plastering 15mm thick in single coat	141
15.	Providing fabricating and erecting Mild Steel	141
16.	Supply of 30.5 M high flag Mast	141

17. Supply of foundation bolts.....	142
18. Supply of LED Aviation light	142
19. Supply of 350W LED	142
20. Supply of 5m high Hot dip galvanised octagonal Pole.....	142
21. Supply of good quality National flag.....	142
22. Erection of Flag Mast and Flag	142
23. Painting with synthetic enamel paint.....	142
24. Supplying of 1.1 KV LT UG cable.....	142
25. Labour charges for laying	142
26. Supplying and making end termination.....	143
27. Supplying and laying.....	143
28. Digging of trench.....	143
29. Digging of trench.....	143
30. Removal of pavement blocks	143
1. SECTION V	145
DRAWINGS	145

SECTION IV

TECHNICAL SPECIFICATIONS**A. GENERAL****1. INTRODUCTION**

The intent of this technical specification covers construction of all civil works as covered in the scope of contract as per drawings supplied by Owner.

All civil works shall be carried out as per design/drawings standardized by the Consultant/Owner and the specification provided by the Consultant/Owner. All standard drawings are enclosed with the tender documents. In case any item is not covered under specification then the same shall be carried out as per CPWD specification and applicable Standards and Codes. Any item for which specification is not provided herein and is not covered under CPWD specification shall be executed as per manufacturer guidelines. All materials shall be of best quality conforming to relevant Standards and Codes. In case of any conflict between Standards/Code and Technical Specification, the provisions of Technical Specification shall prevail, and the Engineer's decision on interpretation shall be final.

The Contractor shall furnish all labor, tools, equipment, materials, temporary works, constructional plant and machinery, fuel supply, transportation and all other incidental items not shown or specified but as may be required for complete performance of the Works in accordance with drawings, specifications and direction of Owner.

Excavated earth is to be disposed from site as instructed, only into approved landfill areas and dump yard. The cost of excavation to include for necessary lead and lift as specified.

All materials including cement, reinforcement steel and structural steel etc. shall be arranged by the Contractor. All testing required shall be arranged by the Contractor at his own cost. The contractor shall execute the work as per the standard Field Quality Plan (FQP) of NMPT.

The bidder shall fully apprise himself of the prevailing conditions at the proposed site, climatic conditions including monsoon patterns, local conditions and site specific parameters and shall include for all such conditions and contingent measures in the bid, including those which may not have been specifically brought out in the specifications.

Level and date of concreting shall be marked on the building from outside at every floor level with proper paint, etc.

All levels and survey work shall be measured by total station and electronic level machine at all floors and places.

Brief Description of Works

The scope of work is defined in the Notice Inviting Tender. The Contractor shall provide all necessary materials, equipment and labour etc. for the execution and maintenance of the work till completion.

The work shall be executed in accordance with the specification stipulated in the Bill of Quantity and other bidding documents read along with CPWD (Central Public Works Department) specifications for civil works and IS codes with up-to-date revisions. For non-schedule items specification as given along with tender document and similar items of CPWD shall be applicable.

The list of references for civil works are CPWD specifications, relevant IS codes and best practices.

For deep excavations, necessary shoring is to be done, the design of which will be provided by the contractor, after assessing site and soil conditions, and work only to be commenced on site after the same is duly approved by NMPT. Any approval if required from the Mineral department or any other statutory body that has jurisdiction on such excavations has to be obtained by the contractor.

All earth used for back filling should be of approved quality.

Portland Cement of IS 8112 shall be used for all cement & concrete works. This will supersede other specifications of cement to be used for the works.

For ready mixed cement concrete, in addition to the CPWD specification, the following also to be noted:

The cost towards cement quantity reduced from the specified quantity in the item due to mixing of fly ash shall be deducted as per relevant BOQ item. The design mix shall be submitted to Engineer in Charge for approval.

All hard ware fittings shall be of best quality and shall be selected as per the Instructions of Engineer in Charge.

Site location, Boundaries and Possession

The location and boundaries of the Site are shown on the Drawing No: [22/105-LP](#). The Contractor shall confine his activities strictly to the allotted site area(s) and

shall not allow his personnel to trespass upon any other areas occupied by the Employer.

1.4 Site Datum and Base Lines

A base line shall be established within the working area by the Contractor. The base line shall be referenced to the site co-ordinate system (based on the Local Coordinates of New Mangalore Port). This bench mark and base line will be the basis for the setting-out for all the Works. The main levels and lines for each portion of the Works shall be established from the bench mark and base line by the Contractor.

1.5 Site Conditions

1.5.1 Location of Work

As per enclosed location plan.

1.5.2 Climate

The climate at Mangalore is tropical with high humidity and a maximum shade temperature of 36°C. The average annual rainfall is approximately 3330 mm and concentrated in the south-west monsoon months of June, July, August and September during which period the average rainfall is as much as 82% of the total annual rainfall.

1.5.3 Wind

The wind in the monsoon months of June, July and August are predominantly from south-west and west with a maximum intensity of 5 on the Beaufort Scale. The winds in the remaining months of the year are predominantly from the north-west and the maximum intensity during this period is also of 5 on the Beaufort Scale.

1.5.4 Cyclones

Even though Mangalore is within the cyclonic area of storms originating in the Arabian Sea and those that enter across the Indian Peninsula from Bay of Bengal, cyclones are not as severe or frequent as in the Bay of Bengal. The maximum wind speed so far recorded in cyclonic storm, generally does not exceed 62 kmph (16.9 m/sec.) except one during 1965 when the maximum speed recorded was 97 kmph (26.9 m/sec.)

1.5.5 Visibility

Thirty year period observations conducted by the Indian Meteorological Department reveal that poor visibility (visibility less than 4 Kms) is encountered for about 10 days in the south-west monsoon period. The maximum number of foggy days in a year is only 3.

1.5.6 Site Preparation

The Contractor shall furnish all necessary supervision, labour, materials, equipment and tools for Site Preparation, clearing and all other works. Clearing shall mean to completely demolish, remove and dispose with all leads, lifts and descents from the area marked, trees, bushes, deadfalls, embedded logs, dislodged roots, stumps, snogs, boulders, mounds, existing structures and other objectionable materials. The areas required to be cleared shall consist of the work Site, ditches, borrow pits, diversions and all other areas necessary for the construction work as directed by the Engineer-in-Charge.

Before any Temporary Works are commenced, the Contractor shall submit his proposal along with complete drawings of all Temporary Work, he may require for the execution of the Works in advance to the Engineer for approval. The Contractor shall also submit his calculations relating to the design of temporary works, strength, etc. if required by the Engineer and shall carry out the modifications that the Engineer may require of such temporary works at Contractor's own cost. The Contractor shall be solely responsible for the stability and safety of all Temporary Work.

It will be the responsibility of the Contractor to make timely procurement of all materials and mobilize all essential equipment for both Temporary and Permanent Works.

1.6 Site Information

The detailed drawing [22/105-LP](#) of the construction site for adaptation of methodology for the construction. However, on account of this change in the geographical profile of site, no extra cost for additional arrangement required to be made will be paid for.

1.7 The Nature of Soil Profile

The site comprises of ordinary soil. The details furnished herein are only for the information/guidelines of the tenderers and the successful contractor shall not claim for any deviation in the actual subsoil profile encountered at site.

1.8 Records

Complete records of all operations connected with the work shall be kept by the Contractor. The Contractor shall submit to the Engineer-in-charge for approval his proposal of the manner of presentation of these records. Three copies of all such records shall be furnished to the Engineer-in-charge on completion of each test or operation.

B. Works

1. Clearing and grubbing road land

Clearing and grubbing road land including uprooting rank vegetation, grass, bushes, shrubs, saplings and trees girth up to 300 mm, removal of stumps of trees cut earlier and disposal of unserviceable materials and stacking of serviceable material to be used or auctioned, including removal and disposal of top organic soil not exceeding 150 mm in thickness by mechanical means using dozer in area of light jungle.

Cutting of trees of girth 300mm to 600 mm including cutting of trunks, branches and removal of stumps stacking of serviceable materials with all lifts, earth filling in the depressions/pits complete as per specification. MORTH specification No.201.

SPECIFICATIONS FOR CLEARING AND GRUBBING

200.1.1. **Scope** - This work shall consist of cutting, removing and disposing of all materials such as trees, bushes, shrubs, stumps, roots, grass, weeds, top organic soil not exceeding 150 mm in thickness, rubbish etc., which in the opinion of the engineer are unsuitable for incorporation in the works, from the area of road land containing road embankment, drains, cross-drainage structures and such other areas as may be specified on the drawings or by the engineer. It shall include necessary excavation, backfilling of pits resulting from uprooting of trees and stumps to required compaction, handling, salvaging, and disposal of cleared materials. Clearing and grubbing shall be performed in advance of earthwork operations and in accordance with the requirements of these Specifications.

200.1.2. **Preservation of property/amenities** - Roadside trees, shrubs, any other plants, pole, lines, fences, signs, monuments, buildings, pipelines, sewers and all highway facilities within or adjacent to the highway which are not to be disturbed shall be protected from injury or damage. The contractor shall provide and install at his own expense, suitable safeguards approved by the engineer for this purpose.

During clearing and grubbing, the contractor shall take all adequate precautions against soil erosion, water pollution, etc., and where required, undertake additional works to that effect vide clause 300.6. Before start of operations, the contractor shall submit to the engineer for approval, his work plan including the procedure to be followed for disposal of waste materials, etc., and the schedules for carrying out temporary and permanent erosion control works as stipulated in clause 300.6.3.

200.1.3. **Methods, tools and equipment** - Only such methods, tools and equipment as are approved by the engineer and which will not affect the property to be preserved shall be adopted for the Work. If the area has thick vegetation/roots/trees, a crawler or pneumatic tyred dozer of adequate capacity may be used for clearance purposes. The dozer shall have ripper attachments for removal of tree stumps. All trees, stumps, etc., falling within excavation and fill lines shall be cut to such depth below ground level that in no case these fall within 500 mm of the subgrade. Also, all vegetation such as roots, under-growth, grass and other deleterious matter unsuitable for incorporation to the satisfaction of the engineer.

On areas beyond these limits, trees and stumps required to be removed as directed by the engineer shall be cut down to 1m below ground level so that these do not present an unsightly appearance.

All branches of trees extending above the roadway shall be trimmed as directed by the engineer.

All excavations below the general ground level arising out of the removal of trees, stumps, etc., shall be filled with suitable material and compacted thoroughly so as to make the surface at these points conform to the surrounding area.

Anti-hills both above and below the ground, as are liable to collapse and obstruct free subsoil water flow shall be removed and their workings, which may extend to several metres, shall be suitably treated.

200.1.4. Disposal of materials - All materials arising from clearing and grubbing operations shall be the property of government and shall be disposed of by the contractor as hereinafter provided or directed by the engineer.

Trunks, branches and stumps of trees shall be cleaned of limbs and roots and stacked. Also boulders, stones and other materials usable in road construction shall be neatly stacked as directed by the engineer. Stacking of stumps, boulders, stones, etc., shall be done at specified spots with all lifts and upto a lead of 1000m.

All products of clearing and grubbing which, in the opinion of the engineer, cannot be used or auctioned shall be cleared away from the roadside in a manner as directed by the engineer. Care shall be taken to see that unsuitable waste materials are disposed of in such a manner that there is no likelihood of these getting mixed up with the materials meant for embankment, subgrade and road construction.

200.1.5. Measurements for payment - Clearing and grubbing for road embankment, drains and cross-drainage structures shall be measured on area basis in terms of hectares. Clearing and grubbing of borrow areas shall be deemed to be a part of works preparatory to embankment construction and shall be deemed to have been included in the rates quoted for the embankment construction item and no separate payment shall be made for the same. Cutting of trees upto 300 mm in girth including removal of stumps and roots after obtaining prior clearance from the forest department/authorities and trimming of branches of trees extending above the roadway shall be considered incidental to the clearing and grubbing operations. Removal of stumps left over after trees have been cut by any other agency shall also be considered incidental to the clearing and grubbing operations.

Cutting, including removal of stumps and roots if trees of girth above 300 mm and backfilling to required compaction shall be measured in terms of number according to the sizes given below :-

- (i) Above 300 mm to 600 mm
- (ii) Above 600 mm to 900 mm
- (iii) Above 900 mm to 1800 mm
- (iv) Above 1800 mm

For this purpose, the girth shall be measured at a height of 1 metre above ground or at the top of the stump if the height of the stump is less than one metre from the ground.

200.1.6. Rates

200.1.6.1. The contract unit rates for the various items of clearing and grubbing shall be payment in full for carrying out the required operations including full compensation for all labour, materials, tools, equipment and incidentals necessary to complete the work. These will also include removal of stumps of trees less than 300 mm in girth as well as stumps left over after cutting of trees carried out by another agency, excavation and back-filling to required density, where necessary, and handling, salvaging, piling and disposing of the cleared materials with all lifts and upto a lead of 1000 m.

200.1.6.2. The contract unit rate for cutting (including removal of stumps and roots) of trees of girth above 300 mm shall include excavation and backfilling to required compaction, handling, salvaging, piling and disposing of the cleared materials with all lifts and upto a lead of 1000 m.

200.1.6.3. Where a contract does not include separate items of clearing and grubbing, the same shall be considered incidental to the earthwork items and the contract unit prices for the same shall be considered as including clearing and grubbing operations.

2. DISMANTLING AND DEMOLISHING

TERMINOLOGY

(i) Deconstruction – Means a selective demolition in which salvage, reuse and recycling of demolished structure is maximized. The term ‘Dismantling’ implies carefully separating the parts without damage and removing. This may consist of dismantling one or more parts of the building as specified or shown on the drawings.

(ii) Demolition: The term ‘Demolition’ implies breaking up. This shall consist of demolishing whole or part of work either manually or using mechanical force (various equipment) or by implosion using explosion, including all relevant items as specified or shown on the drawings.

15.1 GENERAL

This chapter relates to buildings only.

15.1.1 Precautions

15.1.1.1 All materials obtained from dismantling or demolition shall be the property of the Government unless otherwise specified and shall be kept in safe custody until they are handed over to the Engineer-in-Charge/ authorized representative.

15.1.1.2 The demolition shall always be well planned before hand and shall generally be done in reverse order of the one in which the structure was constructed. The operations shall be got approved from the Engineer-in-Charge before starting the work. Due care shall be

taken to maintain the safety measures prescribed in IS 4130 and construction and demolition waste management rules 2016 shall be followed.

15.1.1.3 Necessary propping, shoring and or under pinning shall be provided to ensure the safety of the adjoining work or property before dismantling and demolishing is taken up and the work shall be carried out in such a way that no damage is caused to the adjoining work or property. Wherever specified, temporary enclosures or partitions and necessary scaffolding with suitable double scaffolding and proper cloth covering shall also be provided, as directed by the Engineer-in-Charge. It shall be ensured that no dust is generated while demolishing. Demolition Rules – 2016 shall be followed

15.1.1.4 Necessary steps shall be taken to keep noise and dust nuisance to the minimum. All work needs to be done under the direction of Engineer-in-Charge. Helmets, goggles, safety belts etc., should be used whenever required and as directed by the Engineer-in-Charge. The demolition work shall be proceeded with in such a way that it causes the least damage and nuisance to the adjoining building and the public. Barricading shall be provided as per NGT guidelines.

15.1.1.5 Dismantling shall be done in a systematic manner. All materials which are likely to be damaged by dropping from a height or by demolishing roofs, masonry etc. shall be carefully removed first. Chisels and cutters may be used carefully as directed. The dismantled articles shall be removed manually or otherwise, lowered to the ground (and not thrown) and then properly stacked as directed by the Engineer-in-Charge.

15.1.1.6 Where existing fixing is done by nails, screws, bolts, rivets, etc., dismantling shall be done by taking out the fixing with proper tools and not by tearing or ripping off.

15.1.1.7 Any serviceable material, obtained during dismantling or demolition, shall be separated out and stacked properly as directed by the Engineer-in-Charge within a lead of 50 meters. All unserviceable materials, rubbish etc. shall be disposed of at authorized locations by urban local bodies as directed by the Engineer-in-Charge.

15.1.1.8 The contractor shall maintain/disconnect existing services, whether temporary or permanent, wherever required by the Engineer-in-Charge.

15.1.1.9 No demolition work should be carried out at night especially when the building or structure to be demolished is in an inhabited area.

15.1.1.10 Appropriate screens shall be placed where necessary to prevent injuries due to falling pieces.

15.1.1.11 Water spray shall be used to reduce dust while tearing down plaster from brick work.

15.1.1.12 Safety belts shall be used by labourers while working at higher level to prevent falling from the structure. Wherever, possible mechanized working platform shall be used.

15.1.1.13 First-aid equipment shall be made available at all demolition works of any magnitude.

15.2 RECOMMENDATIONS FOR DEMOLITION OF CERTAIN SPECIAL TYPES AND ELEMENTS OF STRUCTURES

15.2.1 Roof Trusses If a building has a pitched roof, the roof structure should be removed to wall plate level by hand method. Sufficient purlins and bracing should be retained to ensure stability of the remaining roof trusses while each individual truss is removed progressively.

15.2.1.1 Temporary bracing should be added, where necessary, to maintain stability. The end frame opposite to the end where dismantling is commenced, or a convenient intermediate frame should be independently and securely guyed in both directions before work starts.

15.2.1.2 On no account should the bottom tie of roof trusses be cut until the principal rafters are prevented from making outward movement.

15.2.3 Heavy Floor Beams Heavy bulks of timber and steel beams should be supported before cutting at the extremities and should then be lowered to a safe working place.

15.2.4 Jack Arches Where tie rods are present between main supporting beams, these should not be cut until after the arch or series of arches in the floor have been removed. Particular care should be exercised and full examination of this type of structure undertaken before demolition is commenced (see Fig. 15.1). The floor should be demolished in strips parallel to the span of the arch rings (at right angles to the main floor beams).

15.2.5 Brick Arches

15.2.5.1 Expert advice should be obtained and at all stages of the demolition, the closest supervision should be given by persons fully experienced and conversant in the type of work to ensure that the structure is stable at all times.

15.2.5.2 As much dead load as possible may be removed provided it does not interfere with the stability of the main arch rings but it should be noted that the load-carrying capacity of many old arches relies on the filling between the spandrels. On no account should the restraining influence of the abutments be removed before the dead load of the spandrel fill and the arch rings are removed.

15.2.5.3 The normal sequence of demolition is as shown in Fig.

15.2-A, namely: (a) Remove spandrel in filling down to the springing line, (b) Remove the arch rings and (c) Remove the abutment.

15.2.5.4 Special temporary support shall be provided in the case of skew bridges.

15.2.5.5 A single span arch can be demolished by hand by cutting narrow segments progressively from each springing parallel to the span of the arch until the width of the arch has been reduced to a minimum which can then be collapsed (see Fig. 15.2B).

15.2.5.6 Where it is impossible to allow debris to fall to the ground below, centering designed to carry the load should be erected and the arch demolished progressively. The design of the centering should make appropriate allowance for impact.

15.2.5.7 Where deliberate collapse is feasible the crown may be broken by the demolition ball method working progressively from edges to the center (see Fig. 15.2C).

15.2.5.8 Collapse of the structure can be effected in one action by the use of explosives. Charges should be inserted into boreholes drilled in both arch and abutments. This method is the most effective for demolition of tall viaducts. 1

5.2.5.9 In multi-span arches before individual spans are removed, lateral restraint should be provided at the springing level. Demolition may then proceed as for a single span, care being taken to demolish the spandrels down to the springing line as the work proceeds (see Fig. 15.2D). Where explosives are used it is preferable to ensure the collapse of the whole structure in one operation to obviate the chance of leaving unstable portions standing.

15.2.6 Cantilevers (Not part of a Framed Structure) A cantilever type of construction depends for its stability on the super imposed structure. Canopies, cornices, staircases and balconies should be demolished or supported before the tailing down load is removed.

15.2.7 In-situ Reinforced Concrete

15.2.7.1 Before commencing demolition, the nature and condition of the concrete, the condition and position of reinforcement, and the possibility of lack of continuity of reinforcement should be ascertained.

15.2.7.2 Attention should be paid to the principles of the structural design to determine which parts of the structure depend on each other to maintain overall stability.

15.2.7.3 Demolition should be commenced by removing partitions and external non-load bearing cladding. It should be noted that in some buildings the frame may rely on the panel walls for stability.

15.2.7.4 Where hard demolition methods are to be used, the following procedures should be used. (a) Reinforced Concrete Beams For beams, a supporting rope should be attached of preferably at two or three locations to the beam. Then the concrete should be removed from both ends by pneumatic drill and the reinforcement exposed. The reinforcement should then be cut in such a way as to allow the beam to be lowered under control to the floor (see Fig. 15.3A). (b) Reinforced Concrete Columns For columns, the reinforcement should be exposed

at the base after restraining wire guy ropes have been placed round the member at the top. The reinforcement should then be cut in such a way as to allow the column to be pulled down to the floor under control. (see Fig. 15.3B for sequence of operations). (c) Reinforced Concrete Walls Reinforced concrete walls should be cut into strips and demolished as for columns (Fig. 15.3C).

15.3 MEASUREMENTS

15.3.1 All work shall be measured net in the decimal system, as fixed in its place, subject to the following limits, unless otherwise stated hereinafter. (a) Dimensions shall be measured correct to a cm. (b) Areas shall be worked out in sqm correct to two places of decimal. (c) Cubical contents shall be worked out to the nearest 0.01 cum.

15.3.2 Parts of work required to be dismantled and those required to be demolished shall be measured separately.

15.3.3 Measurements of all work except hidden work shall be taken before demolition or dismantling and no allowance for increase in bulk shall be allowed.

15.3.4 Specifications for deduction for voids, openings etc. shall be on the same basis as that adopted for new construction of the work.

15.3.5 Work executed in the following conditions shall be measured separately. (a) Work in or under water and/or liquid mud (b) Work in or under foul position.

15.3.6 Roofs (i) Roof coverings generally including battens boarding, mats, bamboo jaffari or other subsidiary supports shall be measured in square metres except lead sheet roof covering which shall be measured in quintals

(15.2.3) and stone slab roof covering which shall be measured in cubic metres. (ii) Ridges, hips and valleys shall be girthed and included with the roof area. Corrugated or semi corrugated surfaces shall be measured flat and not girthed. (iii) Mud phuska on roofs shall be measured in cubic metres. (iv) Lead sheets in roofs shall be measured in quintals and hips, valleys, flashings, lining to gutter etc. shall be included in this weight. (v) R.B. or R.C.C. roofs shall be measured as specified in

15.3.11. (vi) Supporting members, such as rafters, purlins, beams joists, trusses etc. of wood shall be measured in cubic metres and steel or iron sections, in quintals.

15.3.7 Ceiling (i) The stripping of ceilings shall be measured in square metres. (ii) Dismantling of supporting joists, beams, etc. shall be measured in cubic metres or in quintals as specified in

15.3.6(vi). (iii) Height above floor level, if it exceeds 3.5 m shall be paid for separately.

15.3.8 Flooring and Pavings Dismantling of floors (except concrete and brick floors) shall be measured in square metres. Supports such as joints, beams etc. if any shall be measured as per

15.3.6(vi). Concrete and bricks paving shall be measured as per

15.3.9 Concrete and Brick Roofs and Suspended Floors Demolition of floors and roofs of concrete or brick shall be measured in cubic metres. Beams cantilevers or other subsidiary supports of similar materials, shall be included in the item. In measuring thickness of roofs provided with water proofing treatments with bitumen felts, the thickness of water proofing treatment shall be ignored.

15.3.10 Walls and Piers (i) Taking down walls and independent piers or columns of brick, stone or concrete shall be measured, in cubic metres. All copings, corbels, cornices and other projections shall be included with the wall measurements. (ii) In measuring thickness of plastered walls, the thickness of plaster shall be ignored. (iii) Ashlar face stones, dressed stone work, pre-cast concrete articles, etc. if required to be taken down intact shall be so stated and measured separately in cubic metres. (iv) Cleaning bricks stacking for measurements including all extra handling and removal and disposing off the rubbish as stated shall be enumerated in thousand of cleaned bricks. (v) Cleaning stone obtained from demolished/dismantling stone masonry of any description including ashlar facing dressed stone work, stone slabs or flagging and pre-cast concrete blocks including all extra handling and disposing off the rubbish as stated shall be measured in cubic meters of cleaned stone. (vi) Honey comb works or cavity walls of bricks stone or concrete shall be measured as solid.

15.3.11 Reinforced Concrete and Brick Work Reinforced concrete structures and reinforced brick roofs and walls shall be measured in cubic meters and if reinforcement is required to be salvaged, it shall be so stated. Where reinforcement is required to be separated, scraped and cleaned, the work shall be measured separately in quintal of salvaged steel.

15.3.12 Partitions, Trellis Work etc. Partitions or light walls, of lath and plaster, trellis work, expanded metal, thin concrete or terracotta slabs and other similar materials including frame work if any shall be measured in square meters stating the over all thickness.

15.3.13 Wood Work All wood work including karries average 40 sq.cm or over in section, shall be measured in cubic meters, while that under 40 sq.cm in section, in running meters. Ballies shall be measured in running meters. Boarding including wooden chajjas and sun shades along with supports shall be measured in square meters in its plane.

15.3.14 Steel and Iron Work (i) all steel and iron work shall be measured in quintals. The weight shall be computed from standard tables unless the actual weight can readily be

determined. (ii) Riveted work, where rivets are required to be cut, shall be measured separately. (iii) Marking of structural steel required to be re-erected shall be measured separately. (iv) In framed steel items, the weight or any covering material or filling such as iron sheets and expanded metal shall be included in the weight of the main article unless such covering is not ordered to be taken out separately.

15.3.15 Doors and Windows Dismantling of doors, windows, clerestory windows, ventilators etc. (wood or metal) whether done separately or along with removal of wall by making recess in the wall shall be enumerated. Those exceeding 3 sq.m each in area shall be measured separately. The item shall include removal of chow hats architraves, holdfasts and other attachments. If only shutters are to be taken out it shall be measured separately.

15.3.16 Pipes and Sewer Lines (i) Water pipe lines including rain water pipes with clamps and specials, sewer lines (salt glazed ware or concrete) etc. shall be described by their diameter and length measured in running metres inclusive of joints. (ii) If the joints, special and fittings etc. are required to be separated, it shall be so stated and enumerated. (iii) Pucca drains shall be measured under relevant items. (iv) Valve cistern, public fountain platform, fire hydrants, etc. shall be enumerated. (v) Manholes and inspection chambers shall be enumerated stating the size and depth of manhole/inspection chamber. They shall be classified into different groups depending upon the depth, in unit of half and one metre depth. The depth of the manhole shall be the distance between the top of manhole cover and invert level of the drain. (vi) Ventilating shafts, gully traps, flushing cisterns and other appurtenant items of work shall be enumerated.

15.3.17 Posts or Struts Posts or struts (wood, steel or RCC) section including taking out embedded portion shall be measured in running meters.

15.3.18 Fencing Wire Mesh Wire mesh fencing of any type with frame shall be measured in square metres.

15.3.19 Glazing Taking out any portion of serviceable glass except polished plate, from old sashes, skylights, etc. (any thickness, weight or size) raking out old putty, etc. shall be measured in square meters. Irregular circular panes shall be measured as rectangle or square enveloping the same. The width and height being measured correct to the nearest 0.5 cm.

15.3.20 Road Work (i) Different types of road surfaces shall be measured separately. (ii) Road surfaces metalling or soling (base) shall be measured in square meters. (iii) Concrete paving shall be measured as in

15.3.8 or 15.3.9 as the case may be.

15.4 Rates The rate shall include the cost of all labour involved and tools used in demolishing

and dismantling including scaffolding. The rate shall also include the charges for separating out and stacking the serviceable material properly and disposing off unserviceable material within a distance of 50 meters. The rate shall also include for temporary shoring for the safety of portions not required to be pulled down, or of adjoining property, and providing temporary enclosures or partitions, where considered necessary.

Demolishing R.C.C. work manually/ by mechanical means including stacking of steel bars and disposal of unserviceable material to the appropriate disposal area as per direction of Engineer-in-charge.

3. Earth work excavation by manual means

Earth work excavation by manual means for drains, canals, waste weir, draft, approach channels, key trenches, foundation of bridges and such similar works in all kinds of soils, as per drawing and technical specifications, including setting out, shoring, strutting, barricading, caution lights, removal of stumps and other deleterious matter, excavated surface leveled and sides neatly dressed disposing off the excavated stuff or sorting & stacking the selected stuff for reuse in a radius of 50 m and lift upto 1.5 m including cost of labour, tools & other appurtenances required to complete the work. Depth exceeding 1.5m, but not exceeding 3 m.

2.1 Classification of soils - The earthwork shall be classified under the following categories and measured separately for each category, unless otherwise specified.

The material to be excavated shall be classified as follows: -

2.1.1. Ordinary or soft soil - Generally any soil which yields to ordinary application of pick axes, shovels or any other ordinary digging implements, such as organic soil, turf, gravel, sand, sandy soil, silt, clay, loam, mud, red earth, 'sudde', black cotton soil, soft shale, loose moorum and all soils having soil dry density less than 1.80 gm/cc. (IS: 1498-1970) copy enclosed via Annexure 2-A.1, removal of gravel and/or any modular material having diameter in any one direction not exceeding 75 mm occurring in such strata etc.

2.1.2. Hard and dense soil - All soils classified in soil groups as per IS: 1498-1970 other than what is covered in (a) above; gravel, cobblestone, hard shale, soft Laterite, or any other nodular material having max. diameter in any one direction between 75 mm & 300 mm soft conglomerate, where the stone can be detached from the matrix with pick axes and shovels. This includes soling of roads, paths etc., and hard core, stiff heavy clay, hard shale or compact moorum requiring grafting tool or pick or both and shovel closely applied. Any material, which requires the close application of picks or scarifiers to loosen and not affording resistance to digging greater than the hardest of any soil, mentioned above.

2.1.3. Ordinary or soft rock -

- (i) Rock types such as laterites, shales and conglomerates, varieties of limestone and sandstone etc., which may be quarried or split with crow bars, also including any rock which in dry state may be hard, requiring blasting but which, when wet, becomes soft and manageable by means other than blasting ;
- (ii) Macadam surfaces such as water bound and bitumen/tar bound; compact moorum or stabilised soil requiring grafting tool or pick or both and shovel, closely applied ;
- (iii) Lime concrete, stone masonry in lime mortar and brick work in lime/cement mortar below ground level, reinforced cement concrete which may be broken up with crow bars or picks and stone masonry in cement mortar below ground level; and
- (iv) Boulders which do not require blasting having maximum dimension in any direction of more than 300 mm, found lying loose on the surface or embedded in river bed, soil, talus, slope wash and terrace material of dissimilar origin.

Ordinary rock does not require blasting, wedging or similar means. It may be required a split with crow bars or picks. If required blasting may be resorted to, for loosening the materials but this does not in any way entitle the material to be classified as 'Hard Rock'.

- 2.1.4. Hard rock - Any rock (excluding Laterite and hard conglomerate) or boulder for the excavation of which the use of mechanical plant and/or blasting is required; reinforced cement concrete (reinforcement cut through but not separated from the concrete) below ground level.

Hard rock requires blasting but where blasting is prohibited for any reason, excavation has to be carried out by chiseling, wedging or any other agreed method.

- 2.1.5. Marshy soil - This shall include soils like soft clays and peat excavated below the original ground level of marshes and swamps and soils excavated from other areas requiring continuous pumping or bailing out of water.

- 2.2 Authority for classification - The engineer shall decide the classification of excavation and his decision shall be final and binding on the contractor. Merely the use of explosives in excavation will not be considered, as a reason for higher classification unless blasting is clearly necessary in the opinion of the engineer.

2.3 Types of excavation

- 2.3.1 Surface excavation - Excavation exceeding 1.5 m in width and 10 sq. m on plan but not exceeding 30 cm in depth in all types of soils and rocks shall be described as surface excavation.

Measurements - The length and breadth shall be measured with steel tape correct to the nearest cm and the area worked to the nearest two places of decimal in square meters.

- 2.3.2 Rough excavation and filling - Excavation for obtaining earth from borrow pits, cutting hillside slopes etc., shall be described as rough excavation. Wherever filling is to be done, the earth from excavation shall be directly used for filling and no payment for double handling of earth shall be admissible. Filling of excavated earth shall be done as specified, in case of hill side cutting, where the excavated materials are thrown down the hill slopes; payment for filling excavated earth shall not be admissible.

2.3.3. Excavation over area (All kinds of soils) - This shall comprise

- a) Excavation exceeding 1.5 m in width and 10 sq. m. on plan and exceeding 30 cm in depth.
- b) Excavation for basement, water tanks etc.
- c) Excavation in trenches exceeding 1.5 m in width and 10 sq. m. on plan.

2.3.4 Excavation over area (ordinary / hard rock) - This shall comprise:

- a) Excavation exceeding 1.5 m in width and 10 sq. m. on plan and exceeding 30 cm in depth,
- b) Excavation for basements, water tanks etc,
- c) Excavation in trenches exceeding 1.5 m in width and 10 sq. m. on plan.

2.3.5 Excavation in trenches for foundations and drains (all kinds of soils) - This shall comprise excavation not exceeding 1.5 m in width or 10 sq. m. on plan and to any depth in trenches (excluding trenches for pipes, cables, conduits etc.

2.3.6 Excavation in trenches for foundation and drains (ordinary / hard rock) - This shall comprise excavation not exceeding 1.5 m in width or 10 sq. m. on plan and to any depth in trenches (excluding trenches for pipes, cables, conduits etc.)

2.3.7 Excavation in trenches for pipes, cables etc. refilling –

This shall comprise excavation not exceeding 1.5 mts. In width or 10 sq. m. in plan and to any depth in trenches for pipes, cables etc. and returning the excavated material to fill the trenches after pipes, cables etc. are laid, their joints tested, passed and disposal of surplus excavated material up to 50 m lead.

2.3.8 Width of trench –

a) Up to one meter depth, the authorised width of trench for excavation shall be arrived at by adding 25 cm to the external diameter of pipe (not socket/collar) cable, conduit etc. Where a pipe is laid on concrete bed/cushioning layer, the authorised width shall be the external diameter of the pipe (not socket/collar) plus 25 cm or the width of concrete bed/cushioning layer whichever is more.

b) For depths exceeding one meter, an allowance of 5 cm per meter of depth for each side of the trench shall be added to the authorised width (that is external diameter of pipe plus 25 cm) for excavation. This allowance shall apply to the entire depth of the trench. In firm soils the sides of the trenches shall be kept vertical up to a depth of 2 meters from the bottom. For depths greater than 2 meters, the excavation profiles shall be widened by allowing steps of 50 cm on either side after every two meters from bottom.

c) Where more than one pipe, cable, conduit etc. are laid, the diameter shall be reckoned as the horizontal distance from outside to outside of the outermost pipes, cable, conduit etc.

d) Where the soil is soft, loose or slushy, width of trench shall be suitably increased or side sloped or the soil shored up as directed by the engineer. It shall be the responsibility of the contractor to take complete instructions in writing from the engineer regarding increase in the width of trench, sloping or shoring to be done for excavation in soft, loose or slushy soils.

SPECIFICATIONS FOR EXCAVATION FOR ROADWAYS AND DRAINS

300.1.1. Scope - This work shall consist of excavation, removal and satisfactory disposal of all materials necessary for the construction of roadway, side drains and waterways in accordance with requirements of these specifications and the lines, grades and cross-sections shown in the drawings or as indicated by the engineer. It shall include the hauling and stacking of or hauling to sites of embankment and subgrade construction, suitable cut materials as required, as also the disposal of unsuitable cut materials in specified manner, trimming and finishing of the road to specified dimensions or as directed by the engineer.

300.1.2. **Classification of excavated material**

300.1.2.1. **Classification** - All materials involved in excavation shall be classified by the engineer in the following manner:

a) **Soil** - This shall comprise topsoil, turf, sand, silt, loam, clay, mud, peat, black cotton soil, soft shale or loose moorum, a mixture of these and similar material, which yields to the ordinary application of pick, spade, and/or shovel, rake or other ordinary digging implement. Removal of gravel or any other nodular material having dimension in any one direction not exceeding 75 mm occurring in such strata shall be deemed to be covered under this category.

(b) Ordinary rock (not requiring blasting) - This shall include:

(i) rock types such as Laterites, shales and conglomerates, varieties of limestone and sand stone etc., which may be quarried or split with crow bars, also including any rock, which in dry state may be hard, requiring blasting but, which, when wet, becomes soft and manageable by means other than blasting; (ii) macadam surfaces such as water bound and bitumen/tar bound; soling of roads; paths etc. and hard core; compact moorum or stabilised soil requiring grafting tool or pick or both and shovel, closely applied; gravel and cobble stone having maximum dimension in any one direction between 75 and 300 mm; (iii) lime concrete, stone masonry in lime mortar and brick work in lime/cement mortar below ground level, reinforced cement concrete, which may be broken up with crow bars or picks and sand stone masonry in cement mortar below ground level; and (iv) boulders, which do not require blasting having maximum dimension in any direction of more than 300 mm, found lying loose on the surface or embedded in river bed, soil, talus, slope wash and terrace material of dissimilar origin.

(c) **Hard rock** (requiring blasting) - This shall comprise:

(i) Any rock or cement concrete for the excavation of, which the use of mechanical plant and/or blasting is required; (ii) Reinforced cement concrete (reinforcement cut through but not separated from the concrete) below ground level; and (iii) Boulders requiring blasting.

(d) **Hard rock** (blasting prohibited) - Hard rock requiring blasting as described under (c) but where blasting is prohibited for any reason and excavation has to be carried out by chiselling, wedging or any other agreed method.

(e) **Marshy Soil** - This shall include soils like soft clays and peats excavated below the original ground level of marshes and swamps and soils excavated from other areas requiring

continuous pumping or
bailing out of water.

300.1.2.2. **Authority for classification** - The classification of excavation shall be decided by the engineer and his decision shall be final and binding on the contractor. Merely the use of explosives in excavation will not be considered, as a reason for higher classification unless blasting is clearly necessary in the opinion of the engineer.

300.1.3. **Construction operations**

300.1.3.1. **Setting out** - After the site has been cleared as per clause 201, the limits of excavation shall be set out true to lines, curves, slopes, grades and sections as shown on the drawings or as directed by the engineer. The contractor shall provide all labour, survey instruments and materials such as strings, pegs, nails, bamboos, stones, lime, mortar, concrete, etc., required in connection with the setting out of works and the establishment of bench marks. The contractor shall be responsible for the maintenance of bench, marks and other marks and stakes as long as in the opinion of the engineer, they are required for the work.

300.1.3.2. **Stripping and storing topsoil** - When so directed by the engineer, the topsoil existing over the sites of excavation shall be stripped to specified depths constituting Horizon "A" and stockpiled at designated locations for re-use in covering embankment slopes, cut slopes, berms and other disturbed areas where re-vegetation is desired. Prior to stripping the topsoil, all trees, shrubs, etc., shall be removed along with roots, with approval of the engineer.

300.1.3.3. **Excavation-General** - All excavations shall be carried out in conformity with the directions laid here in under and in a manner approved by the engineer. The work shall be so done that the suitable materials available from excavation are satisfactorily utilized as decided upon beforehand.

While planning or executing excavations, the contractor shall take all adequate precautions against soil erosion, water pollution etc. as per clause 300.6, and take appropriate drainage measures to keep the site free of water in accordance with clause 300.11. The excavation shall conform to the lines, grades, side slopes and levels shown on the drawings or as directed by the engineer. The contractor shall not excavate outside the limits of excavation. Subject to the permitted tolerances, any excess depth/width excavated beyond the specified levels/dimensions on the drawings shall be made good at the cost of the contractor with suitable material of characteristics similar to that removed and compacted to the requirements of clause 300.5

All debris and loose material on the slopes of cuttings shall be removed. No backfilling shall be allowed to obtain slopes excepting that when boulders or soft materials are encountered in cut slopes, these shall be excavated to approved depth on instructions of the engineer and the resulting cavities filled with suitable material and thoroughly compacted in an approved manner. After excavation, the sides of excavated area shall be trimmed and the area contoured to minimise erosion and ponding, allowing for natural drainage to take place

If trees were removed, new trees shall be planted, as directed by the engineer. The cost of planting new trees shall be deemed to be incidental to the work. Annexures 300-A.1 to 300-A.5 are enclosed for offering practical guidance to the field engineers.

300.1.3.4 Methods, tools and equipment - Only such methods, tools and equipment as approved by the engineer shall be adopted / used in the work. If so desired by the engineer, the contractor shall demonstrate the efficacy of the type of equipment to be used before the commencement of work.

300.1.3.5 Rock excavation - Rock, when encountered in road excavation, shall be removed upto the formation level or as otherwise indicated on the drawings. Where, however, unstable shales or other unsuitable materials are encountered at the formation level, these shall be excavated to the extent of 500 mm below the formation level or as otherwise specified. In all cases, the excavation operations shall be so carried out that at no point uncut formation of the rock protrudes above the specified levels. Rocks and large boulders, which are likely to cause differential settlement and also local drainage problems should be removed to the extent of 500 mm below the formation level in full formation width including drains and cut through the side drains.

Where excavation is done to levels lower than those specified, the excess excavation shall be made good as per clauses 300.1.3.3. and 300.1.6 to the satisfaction of the engineer. Slopes in rock cutting shall be finished to uniform lines corresponding to slope lines shown on the drawings or as directed by the engineer. Notwithstanding the foregoing, all loose pieces of rock on excavated slope surface, which move when pierced by a crowbar, shall be removed. Where blasting is to be resorted to, the same shall be carried out as per clause 300.2 and all precautions indicated therein observed. Where presplitting is prescribed to be done for the establishment of a specified slope in rock excavation, the same shall be carried out as in clause 300.3.

300.1.3.6. Marsh excavation -

The excavation of soils from marshes/swamps shall be carried out as per the programme approved by the engineer.

Excavation of marshes shall begin at one end and proceed in one direction across the entire marsh immediately ahead of backfilling. The method and sequence of excavating and backfilling shall be such as to ensure, to the extent practicable, the complete removal or displacement of all muck from within the lateral limits called for on the drawings or as staked by the engineer, and to the bottom of the marsh, firm support or levels indicated.

300.1.3.7. Excavation of road shoulders/verge/median for widening of pavement or providing treated shoulders -

In works involving widening of existing pavements or providing treated shoulders, unless otherwise specified, the shoulder/verge/median shall be removed to their full width and to levels shown on drawings or as indicated by the engineer. While doing so, care shall be taken to see that no portion of the existing pavement designated for retention is loosened or disturbed. If the existing pavement gets disturbed or loosened, it shall be dismantled and

cut to a regular shape with sides vertical and the disturbed/loosened portion removed completely and relaid as directed by the engineer, at the cost of the contractor.

300.1.3.8. Excavation for surface/sub-surface drains –

Where the contract provides for construction of surface/sub-surface drains as in clause 300.9, excavation for these shall be carried out in proper sequence with other works as approved by the engineer.

300.1.3.9. Slides –

If slips, slides, over-breaks or subsidence occur in cuttings during the process of construction, they shall be removed at the cost of the contractor as ordered by the engineer. Adequate precautions shall be taken to ensure that during construction, the slopes are not rendered unstable or give rise to recurrent slides after construction.

If finished slopes slide into the roadway subsequently, such slides shall be removed and paid for at the contract rate for the class of excavation involved, provided the slides are not due to any negligence on the part of the contractor. The classification of the debris material from the slips, slides etc. shall conform to its condition at the time of removal and payment made accordingly regardless of its condition earlier.

300.1.3.10. Dewatering -

If water is met with in the excavations due to springs, seepage, rain or other causes, it shall be removed by suitable diversions, pumping or bailing out and the excavation kept dry whenever so required or directed by the engineer. Care shall be taken to discharge the drained water into suitable outlets as not to cause damage to the works crops or any other property. Due to any negligence on the part of the contractor, if any such damage is caused, it shall be the sole responsibility of the contractor to repair/restore to the original condition at his own cost or compensate for the damage.

300.1.3.11. Disposal of excavated materials –

All the excavated materials shall be the property of the employer. The material obtained from the excavation of roadway, shoulders, verges, drains, cross-drainage works etc., shall be used for filling up of (i) roadway embankment, (ii) the existing pits in the right-of-way and (iii) for landscaping of the road as directed by the engineer, including levelling and spreading with all lifts and lead upto 1000 m and no extra payment shall be made for the same. All hard materials, such as hard moorum, rubble, etc., not intended for use as above shall be stacked neatly on specified land as directed by the engineer with all lifts and lead upto 1000 m.

Unsuitable and surplus material not intended for use within the lead specified above shall also, if necessary, be transported with all lifts and lead beyond initial 1000 m, disposed of or used as directed by the engineer.

300.1.3.12. Backfilling –

Backfilling of masonry/concrete/hume pipe drain excavation shall be done with approved material after concrete/masonry/hume pipe is fully set and carried out in such a way as not to cause undue thrust on any part of the structure and/or not to cause differential

settlement. All space between the drain walls and the side of the excavation shall be refilled to the original surface making due allowance for settlement, in layers generally not exceeding 150 mm compacted thickness to the required density, using suitable compaction equipment such as mechanical tamper, rammer or plate compactor as directed by the engineer.

300.1.4. Plying of construction traffic –

Construction traffic shall not use the cut formation and finished subgrade without prior permission of the engineer. Any damage arising out of such use shall be made good by the contractor at his own expense.

300.1.5. Preservation of property –

The contractor shall undertake all reasonable precautions for the protection and preservation of any or all existing roadside trees, drains, sewers or other sub-surface drains, pipes, conduits and any other structures under or above ground, which may be affected by construction operations and , which, in the opinion of the engineer, shall be continued in use without any change. Safety measures taken by the contractor in this respect shall be got approved from the engineer. However, if any of these objects is damaged by reason of the contractor's negligence, it shall be replaced or restored to the original condition at his expense. If the contractor fails to do so, within the required time as directed by the engineer or if, in the opinion of the engineer, the actions initiated by the contractor to replace/restore the damaged objects are not satisfactory, the engineer shall arrange the replacement/restoration directly through any other agency at the risk and cost of the contractor after issuing a prior notice to the effect.

300.1.6. Preparation of cut formation –

The cut formation, which serves as a subgrade, shall be prepared to receive the sub-base/base course as directed by the engineer.

Where the material in the subgrade (that is within 500 mm from the lowest level of the pavement) has a density less than specified in Table 2, the same shall be loosened to a depth of 500 mm and compacted in layers in accordance with the requirements of clause 305. Any unsuitable material encountered in the subgrade level shall be removed as directed by the engineer and replaced with suitable material compacted in accordance with clause 305.

In rocky formations, the surface irregularities shall be corrected and the levels brought up to the specified elevation with granular base material as directed by the engineer, laid and compacted in accordance with the respective specifications for these materials. The unsuitable material shall be disposed of in accordance with clause 300.1.3.11. After satisfying the density requirements, the cut formation shall be prepared to receive the sub base/base course in accordance with clause 300.10 and 300.11 to receive the sub-base/base course.

300.1.7. Finishing operations –

Finishing operations shall include the work of properly shaping and dressing all excavated

surfaces.

When completed, no point on the slopes shall vary from the designated slopes by more than 150 mm measured at right angles to the slope, except where excavation is in rock (hard or soft) where no point shall vary more than 300 mm from the designated slope. In no case shall any portion of the slope encroach on the roadway.

The finished cut formation shall satisfy the surface tolerances described in clause 900.2. Where directed, the topsoil removed earlier and conserved (clauses 300.1.3.2 and 300.5.3.3) shall be spread over cut slopes, where feasible, berms and other disturbed areas. Slopes may be roughened and moistened slightly, prior to the application of topsoil, in order to provide satisfactory bond. The depth of topsoil shall be sufficient to sustain plant growth, the usual thickness being from 75 mm to 100 mm.

300.1.8. **Measurements for payment –**

Excavation for roadway shall be measured by taking cross-sections at suitable intervals in the original position before the work starts and after its completion and computing the volumes in cu. m. by the method of average end areas for each class of material encountered. Where it is not feasible to compute volumes by this method because of erratic location of isolated deposits, the volumes shall be computed by other accepted methods.

At the option of the engineer, the contractor shall leave depth indicators during excavations of such shape and size and in such positions as directed so as to indicate the original ground level as accurately as possible. The contractor shall see that these remain intact till the final measurements are taken.

For rock excavation, the overburden shall be removed first so that necessary cross-section could be taken for measurement. Where cross-sectional measurements could not be taken due to irregular configuration or where the rock is admixed with other classes of materials, the volumes shall be computed on the basis of stacks of excavated rubble after making 35 per cent deduction therefrom. When volumes are calculated in this manner for excavated material other than rock, deduction made will be to the extent of 16 per cent of stacked volumes.

Works involved in the preparation of cut formation shall be measured in units indicated below:

- (i) Loosening and compacting the loosened material at subgrade..... cum.
- (ii) Loosening and removal of unsuitable material and replacing with a suitable
Material and compacting to required density..... cum.
- (iii) Preparing rocky subgrade..... sq m.
- (iv) Stripping including storing and Reapplication of topsoil.....cum.
- (v) Disposal of surplus material beyond initial 1000 m lead.....cum

300.1.9. **Rates**

300.1.9.1 The contract unit rates for the items of roadway and drain excavation shall be payment in full for carrying out the operations required for the individual items including full compensation for:

(i) setting out; (ii) transporting the excavated materials and depositing the same on sites of embankments, spoil banks or stacking as directed within all lifts and lead upto 1000 m or as otherwise specified; (iii) trimming bottoms and slopes of excavation; (iv) dewatering; (v) keeping the work free of water as per clause 300.11.; and (vi) all labour, materials, tools, equipment, safety measures, testing and incidentals necessary to complete the work to specifications.

Provided, however, where presplitting is prescribed to achieve a specified slope in rock excavation, the same shall be paid for vide clause 300.3.5.

300.1.9.2. The contract unit rate for loosening and recompacting the loosened materials at subgrade shall include full compensation for loosening to the specified depth, including breaking clods, spreading in layers, watering where necessary and compacting to the requirements. Clauses 300.1.9.1. and 300.5.8. shall apply as regards contract unit rate for item of removal of unsuitable material and replacement with suitable material respectively.

300.1.9.3. The contract unit rate for item of preparing rocky subgrade as per clause 300.1.6. shall be full compensation for providing, laying and compacting granular base material for correcting surface irregularities including all materials, labour and incidentals necessary to complete the work and all leads and lifts.

300.1.9.4. The contract unit rate for the items of stripping and storing topsoil and of reapplication of topsoil shall include full compensation for all the necessary operations including all lifts, but leads upto 1000 m.

300.1.9.5. The contract unit rate for disposal of surplus earth from roadway and drain excavation shall be full compensation for all labour, equipment, tools and incidentals necessary on account of the additional haul or transportation involved beyond the initial lead of 1000 m.

PROVIDING AND FILLING IN FOUNDATION WITH GRANITE / TRAP BROKEN METAL

Providing and Filling in foundation with granite / trap broken metal 100mm. and down size, with approved sand including hand packing, ramming, watering, including cost of all materials and labour with all lead and lift. Complete as per specifications.

SPECIFICATIONS FOR CEMENT CONCRETE

4.2.0. This shall be prepared by mixing graded stone or brick aggregate of nominal size as specified with fine aggregate and cement in specified proportions with required quantity of water. The grading and quality of aggregates shall be such as to give minimum compressive strength of 140 kg/cm² and 210 kg / cm² at 7 days and 28 days respectively in case of mix 1:2:4, (One cement - two Coarse sand - four stone aggregate).

One sample consisting of 6 cubes 15x15x15 cm shall be taken for every 15 cubic meter or part thereof cement concrete 1:2:4. The cube tests shall not be carried out in case the quantity of cement concrete placed on any day is less than 15 cubic meter unless otherwise specific. For other details, refer section on R.C.C. work.

4.2.1. Proportioning - It shall be done by volume. Boxes of suitable size shall be used for measuring sand and aggregate. The internal dimensions of the boxes shall be generally 35 X

25 X40 cm deep or as otherwise approved by the engineer. The unit of measurement of cement shall be a bag of 50 kg. and this shall be taken as 0.035 cubic meter. While measuring the aggregate, shaking, ramming or heaping shall not be done. The proportioning of sand shall be on the basis of its dry volume and in case of damp sand, allowances for bulk age shall be made as given for mortar.

4.2.2. Preparation - This shall be prepared by mixing coarse aggregate, fine aggregate and cement in specified proportions with required quantity of water. Nominal size and quality of aggregate shall be as specified.

Except where brick aggregate is used in cement concrete, minimum compressive strength on works test for different concrete mixes shall be as specified for various grades prepared by volume basis, in Table 5 below. The work test shall be carried out for every 15 cum of a day's concreting unless otherwise specified.

Table 5

Concrete mix	Min compressive strength on 15 cm cube in Kg / cm ²	
	7 days strength	28 days strength
1:1:2	210	315
1:1½ :3		265
1:2:4	140	175

4.2.2.1. Mixing - Concrete shall be mixed in mechanical batch type concrete mixers conforming to IS: 1791 having two blades and fitted with power loader (lifting hopper type). Half bag mixers and mixers without lifting hoppers shall not be used for mixing concrete. In exceptional circumstances, such as mechanical break down of mixer, work in remote areas or power breakdown and when the quantity of concrete work is very small, hand mixing may be done with the specific prior permission of the engineer in writing subject to adding 10% extra cement. When hand mixing is permitted, it shall be carried out on a watertight platform and care shall be taken to ensure that mixing is continued until the concrete is uniform in colour and consistency. Before mixing the brick aggregate shall be well soaked with water for a minimum period of two hours and stone aggregate or gravel shall be washed with water to remove, dirt, dust and other foreign materials. For guidance, the mixing time may be 1½ to 2 minutes, for hydrophobic cement it may be taken as 2½ to 3 minutes.

4.2.2.2. Power loader - Mixer will be fitted with a power loader complying with the following requirements.

a). The hopper shall be of adequate capacity to receive and discharge the maximum nominal batch of unmixed materials without spillage under normal operating conditions on a level site.

Note - In such a case the volume of the maximum nominal batch of mixed material is 50% greater than the nominal mixed batch capacity.

b). The minimum inside width of the feeding edge of the hopper shall be as specified below in Table 6.

Table 6

Nominal size of mixer (T, NT or R), litre	Minimum inside width of hopper feeding edge in mm

140	1.0
200	1.1
280	1.2
375	1.4
500	1.5
1000	2.0

~~~~~ T = tilting; NT = non-tilting; R = Reverse

The design of the loader shall be such that it allows the loading hopper to be elevated to such a height that the center line of the chute plate of the hopper when in discharge position, is at an angle of not less than 50° to the horizontal. A mechanical device to aid discharge of the contents as quickly as possible from the hopper to the drum may also be provided. Even when a mechanical device is provided, it is recommended that the angle of center line of the chute plate of the hopper when in discharge position, should be as large as practicable, preferably not less than 40° to horizontal.

When the means of raising and lowering the loading hopper includes flexible wire ropes winding on to a drum or drums, the method of fastening the wire to rope to the drums shall be such as to avoid, as far as possible any tendency to cut the strands of the ropes and the fastening should preferably be positioned clear of the barrel of the drum for example, outside the drums flange. When the loading hopper is lowered to its normal loading position, there should be at least one and half drums of rope on the drum.

Clutch brake and hydraulic control lever shall be designed so as to prevent displacement by liberation or by accidental contact with any person.

The clutch and brake control arrangements shall also be so designed that the operator can control the falling speed of the loader.

Safety device shall be provided to secure the hopper in raised position when not in use

4.2.2.3. Mixing efficiency - The mixer shall be tested under normal working conditions in accordance with the method specified in IS - 4643 with a view to check its ability to mix the ingredients to obtain concrete having uniformity within the prescribed limits. The uniformity of mixed concrete shall be evaluated by finding the percentage variation in quantity (mass in water) of cement, fine aggregate and coarse aggregate in a freshly mixed batch of concrete.

The percentage variation between the quantities of cement, fine aggregate and coarse aggregates (as found by weighing in water) in the two halves of a batch and average of the two halves of the batch shall not be more than the following limits -

|                  |    |
|------------------|----|
| Cement           | 8% |
| Fine aggregate   | 6% |
| Coarse aggregate | 5% |

4.2.2.4. Machine mixing - The mixer drum shall be flushed clean with water. Measured quantity of coarse aggregate shall be placed first in the hopper. This shall be followed with measured quantity of fine aggregate and then cement. In case fine aggregate is damp, half the required quantity of coarse aggregate shall be placed in the hopper, followed by fine aggregate and cement. Finally the balance quantity of coarse aggregate shall be fed in the hopper, & then the dry materials are slipped into the drum by raising the hopper. The dry material shall be mixed for at least four turns of the drum. While the drum is rotating, water

shall be added gradually to achieve the water cement ratio as specified or as required by the engineer. After adding water, the mixing shall be continued until concrete of uniform colour, uniformly distributed material and consistency is obtained. Mixing shall be done for at least two minutes after adding water. If there is segregation after unloading from the mixer, the concrete should be remixed. The drum shall be emptied before recharging. When the mixer is closed down for the day or at any time exceeding 20 minutes, the drum shall be flushed clean with water.

4.2.2.5 Hand mixing - When hand mixing has been specifically permitted in exceptional circumstances by the engineer in writing, subject to adding 10% extra cement, it shall be carried out on a smooth, clean and water tight platform of suitable size. Measured quantity of sand shall be spread evenly on the platform and the cement shall be dumped on the sand and distributed evenly. Sand and cement shall be mixed intimately with spade until mixture is of even colour throughout. Measured quantity of coarse aggregate shall be spread on top of cement sand mixture and mixing done by shoveling and turning till the coarse aggregate gets evenly distributed in the cement sand mixture. Three quarter of the total quantity of water required shall be added in a hollow made in the middle of the mixed pile and the material is turned towards the middle of pile with spade. The whole mixture is turned slowly over and again and the remaining quantity of water is added gradually. The mixing shall be continued until concrete of uniform colour and consistency is obtained. The mixing platform shall be washed and cleaned at the end of the day.

4.2.3. Workability - The quantity of water to be used for each mix shall be such that the concrete is of adequate workability for the placing conditions of the concrete and can properly be compacted with the means specified. Generally, the quantity of water to be used for each mix of 50 Kgs cement shall not be more than 34 litres for 1:3:6 mix, 30 litres for 1:2:4 mix, 30 litres for 1:1½:3 mix and 25 litres for 1:1:2 mix. In case of vibrated concrete, the quantity of water may be suitably reduced to avoid segregation. The quantity of water shall be regulated by carrying out regular slump tests as described in Annexure 4.A.1. The slump and workability for different kind of works shall be as per Table 7 below

Table 7

| Placing conditions.                                                                                       | Degree of workability | Value of workability                                                      |
|-----------------------------------------------------------------------------------------------------------|-----------------------|---------------------------------------------------------------------------|
| Concreting of shallow Sections with vibration                                                             | Very low              | 0.75-0.80<br>Compacting factor.                                           |
| Concreting of lightly reinforced section with vibration.                                                  | Low                   | Slump up to 25 mm, 10-5 Seconds, vee bee time 0.8-0.85 compacting factor. |
| Concreting of lightly reinforced Section without vibration or heavily reinforced sections with vibration. | Medium                | 25-75 mm, slump for 20 mm aggregate.                                      |
| Concreting of heavily reinforced sections without vibration.                                              | High                  | 75-125 mm slump for 20 mm aggregate.                                      |

Note - Where considered necessary, the workability of the concrete may also be ascertained by compacting factor test and vee-bee consistometer method as specified in IS: 1199. For suggested ranges of value of workability of concrete by the above methods, reference may be made to IS: 456-2000.

4.2.4. Transportation - Concrete shall be transported from the mixer to the place of laying as rapidly as possible by methods which will prevent the segregation or loss of any of the ingredients and maintaining the required workability.

4.2.5. Placing - The concrete shall be deposited as nearly as practicable in its final position to avoid rehandling. It shall be laid gently (not thrown) and shall be thoroughly vibrated and compacted before setting commences and should not be subsequently disturbed. Method of placing shall be such as to preclude segregation. Care shall be taken to avoid displacement of reinforcement or movement of form work and damage due to rains.

4.2.6. Compaction - Concrete shall be thoroughly compacted and fully worked around embedded fixtures and into corners of the form work. Compaction shall be done by mechanical vibrator of appropriate type till a dense concrete is obtained. The mechanical vibrators shall conform to IS: 2505 specifications for concrete vibrators (immersion type). To prevent segregation, over vibration shall be avoided. The use of mechanical vibrator may be relaxed by the engineer at his discretion for certain items and permit hand compaction. Hand compaction shall be done with the help of tamping rods. Compaction shall be completed before the initial setting starts. For the items where mechanical vibrators are not to be used, the contractor shall take permission of the engineer in writing before the start of the work. After compaction the top surface shall be finished even and smooth with wooden trowel before the concrete begins to set.

4.2.7. Construction joints - Connecting shall be carried out continuously up to construction joints. The position and arrangement of construction joints shall be as shown in the structural drawings or as directed by the engineer. Number of such joints shall be kept minimum and shall be kept as straight as possible.

4.2.7.1. When the work has to be resumed on a surface which has hardened, such surface shall be roughened. It shall then be swept clean and thoroughly wetted. For vertical joints, neat cement slurry, of workable consistency by using 2kgs of cement per sq m shall be applied on the surface before it is dry. For horizontal joints, the surface shall be covered with a layer of mortar about 10-15 mm thick composed of cement and sand in the same ratio as the cement and sand in concrete mix. This layer of cement slurry or mortar shall be freshly mixed and applied immediately before placing of the concrete

4.2.7.2. Where the concrete has not fully hardened, all laitance shall be removed by scrubbing the wet surface with wire or bristle brushes, care being taken to avoid dislodgement of particles of coarse aggregate. The surface shall be thoroughly wetted and all free water removed. The surface shall then be coated with neat cement slurry @ 2 kgs of cement per sqm. On this surface, a layer of concrete not exceeding 150 mm in thickness shall first be placed and shall be well rammed against corners and close spots; work, thereafter, shall proceed in the normal way.

4.2.8. Concreting under special conditions

4.2.8.1 Work in extreme weather conditions - During hot and cold weather, the concreting shall be done as per the procedure set out in IS: 7861(Part-I) and IS: 7861(Part II) respectively. Concreting shall not be done when the temperature falls below 4.5° C. In cold weather, the concrete placed shall be protected against frost. During hot weather, it shall be ensured that the temperature of wet concrete does not exceed 38°C.

Under water concreting - Concrete shall not be deposited under water if it is practicable to de-water the area and place concrete in the regular manner. The concrete shall contain at least 10% more cement than that required for the same mix placed in dry conditions, the quantity of extra cement varying with conditions of placing with prior written permission of the engineer. Such extra cement will be paid extra. The volume of coarse aggregate shall not be less than 1½ times nor more than twice the fine aggregate and slump not less than 100 mm nor more than 180 mm. Where found necessary to deposit any concrete under water, the method, equipment, materials and mix shall first be got approved by the engineer. Concrete shall be deposited continuously until it is brought to required height. While depositing, the top surface shall be kept as nearly level as possible and the formation of heaps shall be avoided. The concrete shall be deposited under water by one of the approved methods such as Tremie method, drop bottom bucket, bags, grouting etc. as per details given in IS: 456-2000. If it is necessary to raise the water after placing the concrete, the level shall be brought up slowly without creating any waves or commotion tending to wash away cement or to disturb the fresh concrete in any way

4.2.9. Curing - When the concrete begins to harden i.e. two to three hours after compaction, the exposed surfaces shall be kept damp with moist gunny bags, sand or any other material approved by the engineer 24 hours after compaction, the exposed surface shall be kept continuously in damp or wet conditions by ponding or by covering with a layer of sacking, canvass, Hessian or similar absorbent materials and kept constantly wet for at least 7 days where ordinary Portland cement is used and 10 days, where Portland pozzolana cement is used from the date of placing of concrete. For concrete work with other types of cement, curing period shall be as directed by the engineer.

Approved curing compounds may be used in lieu of moist curing with the permission of the engineer. Such compounds shall be applied to all exposed surfaces of the concrete as soon as possible after the concrete has set

4.2.9.1 Freshly laid concrete shall be protected from rain by suitable covering.

4.2.9.2 Over the foundation concrete, the masonry work may be started after 48 hours of its compaction but the curing of exposed surfaces of cement concrete shall be continued along with the masonry work for at least 7 days. And where cement concrete is used as base concrete for flooring, the flooring may be commenced before the curing of period of base concrete is over but the curing of base concrete shall be continued along with top layer of flooring for a minimum period of 7 days.

4.2.10. Testing of concrete will be done as described in section on R.C.C

4.2.11. Form work - Form work shall be as specified in R.C.C section and shall be paid for separately unless otherwise specified.

4.2.12. Finishes - Plastering and special finishes other than those, obtained through form work shall be specified and paid for separately unless otherwise specified.

4.2.13. Measurements

4.2.13.1. Dimensions of length, breadth and thickness shall be measured correct to nearest cm. Except for the thickness of slab and partition which shall be measured to nearest 5 mm. Area shall be worked out to nearest 0.01 square meter and the cubic contents of consolidated concrete shall be worked out nearest 0.001 cubic meters. Any work done in excess over the specified dimension or as required by engineer is ignored.

4.2.13.2. Concrete work executed in the following conditions shall be measured separately

At or near the ground level



Work in liquid mud

c. Work in or under foul positions

4.2.13.3. Cast-in-situ concrete and or precast concrete work shall be measured in stages described in the item of work, such as -

At or near the ground level,

Up to specified floor level

Between two specified floor levels

Up to specified height above or depth below plinth level/ defined datum level  
Between two specified heights or depths with reference to plinth level / defined datum level

4.2.13.4. No deduction shall be made for the following -

a. Ends of dissimilar materials for example beams, girders, rafters, purlins trusses corbels and steps up to 500sq. cm in cross sections.

b. Opening up to 0.1sq meter (1000sq.cm).

c. Volume occupied by pipes, conduits, sheathing etc. not exceeding 100sq cm each in cross sectional areas.

d. Small voids such as shaded portions in Figure when these do not exceed 40sq cm each in cross section.

Note - In calculating area of opening, the thickness of any separate lintel or still shall be included in the height. Nothing extra shall be payable for forming such openings or voids.

4.2.13.5. Cast-in-situ concrete shall be classified and measured as follows -

Foundation, footings, bases for columns

Walls (any thickness) including attached pilasters, buttresses, plinth and string courses, fillets etc.

Shelves

Slabs

Chajjas including portions bearing on the wall

Lintels, beams and Bressemmers

Columns, piers abutments, pillars, post and struts

Stair case including stringer beams but excluding landings.

Balustrades, newels and sailing

Spiral staircase (including landing)

Arches

Domes, vaults

Shell roof, arch ribs and folded plates

Chimneys and shaft.

Breast walls, retaining, walls, return walls

Concrete filling to precast components

Kerbs, steps and the like

String or lacing courses, parapets, copings, bed block, anchor blocks, plain window sills and the like

Cornices and moulded windows sills.

Louvers, fins, fascia.

4.2.13.6. Precast cement concrete solid articles shall be measured separately and shall include muse of moulds, finishing the top surfaces even and smooth with wooden trowel, before setting in position in cement mortar 1:2 (1 cement -2 coarse sand). Plain and moulded work shall be measured separately and the work shall be classified and measured as under -

| Classification                                                                                          | Method of measurement                                            |
|---------------------------------------------------------------------------------------------------------|------------------------------------------------------------------|
| a. Wall panels<br>In square meters<br>stating the thickness                                             | In square meters stating the thickness                           |
| b. String or lacing courses, coping, bed<br>plats, plain windows sills, shelves, louvers,<br>steps etc. | In cubic meters                                                  |
| c. Kerbs, edgings etc. In cubic meters                                                                  | In cubic meters                                                  |
| d. Solid block work                                                                                     | In square meters stating the thickness<br>or in cubic meters.    |
| e. Hollow block work                                                                                    | In square meters stating the thickness<br>or in cubic meters.    |
| f. Light weight Partitions                                                                              | In square meters stating the thickness<br>or in cubic<br>meters. |

4.2.14. Rate - The rate is inclusive of the cost of labour and materials involved in all the operations described above.

## 7.0 STONE WORK

### 7.0 TERMINOLOGY

Ashlar

Stone masonry using dressed square stone blocks of given dimensions having faces perpendicular to each other and laid in courses.

Bed Joint

The joint where one stone presses on another for example, a horizontal joint in a wall or radiating joint between the voussoirs or arch

Block

A concrete masonry unit with any one of the external dimension greater than the corresponding dimension of a brick and having one or more large holes or cavities which either pass through the block (open cavity) or do effectively pass through the block (closed cavity) and having the solid material between 50% and 75% of the total volume of the block calculated from the overall dimensions.

(b) Solid Block: A concrete masonry unit with external dimensions greater than corresponding dimension of a brick and having solid material not less than 75% of the total volume of the block calculated from over all dimension.

Bond

An interlocking arrangement of structural units in a wall to ensure stability.

Bond Stone (through Stone)

Selected long stone used to hold a wall together transversely

Corbel

Stone bonded well into the wall with part of it projecting out of the face of wall to form a bearing surfaces.

Cramp A small piece of metal or the hardest or tough test stone procurable, sunk in mortices and fixed across joints as additional ties. The ends of metal cramps are bent at right angles and stone cramps are dovetailed Course A layer of stones in wall including the bed mortar. Dowels Dowels are small sections of metal, stone or pebbles bedded with mortar in corresponding mortise in bed or side joint or adjacent stones Jamb The part of the wall at the side of an opening

5.1.3.7 Thermo Mechanically treated reinforcement bars:

(a) There is no BIS code for TMT bars. The available code BIS 1786 pertains to HSD Bars. Therefore there should be no stipulation that TMT bars should conform to relevant BIS code. (b) The TMT bars are being produced under valid license from either of the firms namely Temporal, There Eco Turbo & Turbo Quench. These firms have acquired patents and are giving licenses to various producers to produce TMT Bars.

(c) The TMT bars shall conform to IS 1786 pertaining to Fe 415 D or Fe 500 D or Fe grade of steel as specified.

(d) In design and construction of reinforced concrete building in seismic zone III and above, steel reinforcement of Grade Fe 415 D shall be used. However, high strength deformed steel bars, produced by thermo mechanical treatment process of grade Fe 415, Fe 500 and Fe 550 having elongation more than 14.5. % and conform to other requirements of Fe 415 D, Fe 500 D and Fe 550 D respectively of IS 1786 may also be used for reinforcement. In future, latest provision of IS 456 and IS 13920 or any other relevant code as modified from time to time shall be applicable.

#### 4. Earth work excavation by manual means

Earth work excavation by manual means for drains, canals, waste weir, draft, approach channels, key trenches, foundation of bridges and such similar works in all kinds of soils, as per drawing and technical specifications, including setting out,

shoring, strutting, barricading, caution lights, removal of stumps and other deleterious matter, excavated surface leveled and sides neatly dressed disposing off the excavated stuff or sorting & stacking the selected stuff for reuse in a radius of 50 m and lift upto 1.5 m including cost of labour, tools & other appurtenances required to complete the work. Depth exceeding 1.5m, but not exceeding 3 m.

5. Dismantling steel work in built up sections

Dismantling steel work in built up sections in angles, tees, flats and channels including all gusset plates, bolts, nuts, cutting rivets, welding etc. including dismembering and stacking to the appropriate disposal area as per direction of Engineer-in-charge.

6. Providing and Filling in foundation with granite

KSRB 2.8 : Providing and Filling in foundation with granite / trap broken metal 100mm. and down size, with approved sand including hand packing, ramming, watering, including cost of all materials and labour with all lead and lift. complete as per specifications. specification. No. KBS.

7. Providing and laying in position plain cement concrete

Providing and laying in position plain cement concrete for levelling course for all works in foundation. The granite/trap/basalt crushed graded coarse aggregates and fine aggregates as per relevant IS Codes machine mixed, laid in layers not exceeding 150 mm thickness, well compacted using plate vibrators, including all lead & lifts, cost of all materials of quality, labour, Usage charges of machineries, curing, and all the other appurtenances required to complete the work as per technical specifications. (The cost of steel reinforcement & formwork shall be paid separately) Mix 1:3:6 (M10) Using 20 mm nominal size graded crushed coarse aggregates.

8. Providing and constructing laterite size stone masonry

Providing and constructing laterite size stone masonry in CM 1:6 including cost and conveyance of all materials curing etc complete as per specification. I.S. 3620/1979 having compressive strength not less than 3.5 N/mm<sup>2</sup> for saturated dry samples for foundation.

9. Providing and constructing laterite size stone masonry

Providing and constructing laterite size stone masonry in CM 1:6 including cost and conveyance of all materials curing etc complete as per specification. I.S. 3620/1979 having compressive strength not less than 3.5 N/mm<sup>2</sup> for saturated dry samples. For super structure.

**10. Providing and laying in position plain cement concrete**

Providing and laying in position plain cement concrete of mix 1:2:4 with cement @ 240kgs, with 20mm and down size graded granite metal coarse aggregates @ 0.69 cum and fine aggregates @ 0.459cum, machine mixed, concrete laid in layers not exceeding 15 cms. thick, well compacted, for coping. Including cost of all materials, labour, HOM, curing complete as per specifications. Specification No. KBS 4.1, 4.2

**11. Providing Thermo-Mechanically Treated bars**

Providing Thermo-Mechanically Treated bars of grade Fe-550 steel reinforcement for RCC work including straightening, cutting, bending, placing in position, binding and anchoring to adjacent members wherever necessary complete as per Design including cost of material, labour, usage charges complete as per specifications. (The laps and wastages shall not be measured separately)

**12. Providing and laying in position Reinforced cement concrete**

Providing and laying in position Reinforced cement concrete for all Sub structures of building, Irrigation works, Sub structure works of bridges, Drain works & other parallel works from 0.50m to 3.50 m height. The granite /trap /basalt crushed graded coarse aggregates and fine aggregates as per relevant IS Codes machine mixed with super plasticisers, laid in layers, well compacted using needle vibrators, providing weep holes wherever necessary, including all lead & lifts, cost of all materials of quality, centering, including shuttering, strutting, propping etc., confirming to the requirements of relevant IS codes, labour, Usage charges of machinery, curing and all other appurtenances required to complete the work as per technical specifications. (The cost of steel reinforcement to be paid separately) M25 Design Mix Using 20 mm nominal size graded crushed coarse aggregates.

**13. Filling available excavated earth**

KSRB 2.3 : Filling available excavated earth ( excluding rock ) in sides of foundations upto plinth in layers not exceeding 20 cms. in depth, compacting each deposited layer by ramming after watering with lead upto 50 m. and lift upto 1.5 m. including cost of all labour complete as per specifications. specification. No. KBS 2.9

**14. Providing cement plastering 15mm thick in single coat**

KSRB15-5 : Providing cement plastering 15mm thick in single coat with cement mortar to brick masonry including rounding of corners wherever required smooth rendering, providing and removing scaffolding, including cost of materials, labour, curing complete as per specifications. cement mortar 1:6

**15. Providing fabricating and erecting Mild Steel**

Providing fabricating and erecting Mild Steel Square Hollow Section(SHS) for gate of approved make and quality as shown in the drawing including cost and conveyance of all materials ,labour, cost of anchor plates, bolts, cutting, welding transportation etc., fixing in position and applying a priming coat with two coats of paint including welding etc., and usage charges of machinery complete as per specifications and as per directions of the Engineer-in-Charge.

**16. Supply of 30.5 M high flag Mast**

Supply of 30.5M high flag Mast. Mast shaft shall be in three sections, hot dip galvanised and suitable for wind velocity as per IS 875. It includes a special type of Dome. The shaft shall be PU painted with a coating of primer, and PU paint. It includes system for Raising

Lowering of Flag. It shall have double drum winch, 6 mm dia stainless steel wire rope and integral power tool for the raising and lowering of Flag. Suitable control panel shall be provided for reversing operation of Power tool motor. Also includes LED aviation system with 3C x 2.5 Sqmm Cu armoured cable with earthing etc., complete as per specifications and as per the directions of the Engineer Incharge.

17. Supply of foundation bolts

Supply of foundation bolts manufactured from special steel along with nuts, washers, anchor plate and common template etc complete as per specifications and as per the directions of the Engineer Incharge.

18. Supply of LED Aviation light

Supply of LED Aviation light and its fixing arrangement- Complete set - Fiber Canopy as per specifications and as per the directions of the Engineer In charge.

19. Supply of 350W LED

Supply of 350W LED flood lights Complete set.

20. Supply of 5m high Hot dip galvanised octagonal Pole

Supply of 5m high Hot dip galvanised octagonal Pole suitable to mount one number flood light fitting at top including foundation bolts.

21. Supply of good quality National flag

Supply of good quality National flag of suitable material and of 30ft x 20 ft size for 30.50 m high flag Mast as per specifications and as per the directions of the Engineer In charge.

22. Erection of Flag Mast and Flag

Erection of Flag Mast and Flag with the help of suitable equipment's and assembly of operating system including commissioning of flag mast as per specifications and as per the directions of the Engineer In charge.

23. Painting with synthetic enamel paint

Painting with synthetic enamel paint of approved brand and manufacture to give an even shade :Two coats on new work after thoroughly brooking the surface to remove all dirt, dust, mortar drops and foreign matter including preparing the surface even and sand paper smooth, cost of materials, labour complete as per specifications and as per directions of Engineer-in-charge.

24. Supplying of 1.1 KV LT UG cable

Supplying of 1.1 KV LT UG cable XLPE insulated, PVC extruded inner sheath armoured UG LT cable as per IS-7098 Part-1, Armouring strip thickness in average +5% and resistivity as per IS-3975. i) 3.5 core 25 sq.mm

25. Labour charges for laying

Labour charges for laying of 3.5 core 25 sq.mmsize 1.1KV class XLPE UG

able/on wall/GI Pipe/HDPE pipe as required etc., complete.

**26. Supplying and making end termination**

Supplying and making end termination with metal glands, lugs of LT cable for 3.5 core 25 sq.mm.

**27. Supplying and laying**

Supplying and laying of 63 mm OD/50 mm ID as per IS 14930 part II double walled corrugated (DWC) HDPE Pipe including all necessary connecting sockets/ couplings/Tees/Bends/End-caps of same materials in existing trench suitable for drawing underground cables.

**28. Digging of trench**

Digging of trench of 0.6 Meter deep x 0.3 Meter wide, refilling the trench to the required ground level and consolidating etc., complete.  
i) Hard Soil.

**29. Digging of trench**

Digging of trench of 0.6 Meter deep x 0.3 Meter wide, refilling the trench to the required ground level and consolidating etc., complete.  
i) C.C.Cutting

**30. Removal of pavement blocks**

Removal of pavement blocks and re-fixing to its original conditions for laying of cable as required.

**31. Control Panel**

The control panel shall be made of SS 304 grade, suitable for forward and reverse operation 1.5HP Capacity, 6 Pole, Single Speed Motor. Method of operation shall be Integral Motor / Manual handle with mechanical tripping facility.

**32. Stainless steel wire Rope**

Stainless Steel Wire Rope shall be 7/19 construction, two wire continuous with 6mm dia having braking load capacity.

**33. Lightning protection**

Lightning Protection finial of G.I single spike of length 1800mm shall be provided.

**34. Flag mast material**

Flag Mast material shall be constructed from E350 grade as per BS-EN10 025 (IS 2062) & standard for galvanization shall be as per BS EN ISO 1461.

**35. warranty / guarantee period**

During 1 year Warranty / Guarantee period required spare flags shall be kept ready as and when required for replacement.

**36. Technical Specification of 350W LED Flood Light Fittings :**

The Technical Specification of 350W LED Flood Light Fittings suitable for octagonal pole applications are as follows :

( Necessary warranty certificate of manufacturer for 350W LED Flood Light Fittings has to be submitted for acceptance )

- Rated voltage: 230 V AC, 50Hz. Operating voltage: 120-270 V AC
- System wattage : 350W
- P.F:  $\geq 0.90$
- Luminaire efficacy : 120 lm / W or more
- CCT & CRI :- 5000 K &  $>70$
- Driver efficiency :  $>85\%$
- Total lumens :  $> = 42000$  (system efficiency)
- Protection: O.C, SC, Surge protection of min10 KV, SPD
- Mounting: bracket
- Main housing/heat shrinks material: Aluminum extruded/ Aluminum PDC
- Housing end caps & CG box: aluminum PDC
- Front cover : clear toughened glass
- LED lumens maintenance : 50000 hrs @ L70
- Control gear: isolated, electronic, CC drive
- Hardware: SS
- IP:66
- Impact resistance: IK07
- Name of the make: shall be engraved/embossed/printed on light fitting
- Fitting shall have NABL certification



**1. SECTION V****DRAWINGS****Brief Description of drawing**

The Works are shown in the following drawings that are issued as a part of the Tender Documents:

| Sl. No | Drawing No. | Description                    |
|--------|-------------|--------------------------------|
| 1      | 22/105-LP   | Location Drawing               |
| 2      | 22/105-01   | Elevation                      |
| 3      | 22/105-02   | Elevation & base plate details |
| 4      | 22/105-03   | Sectional Elevation            |
| 5      | 22/105-04   | 04                             |

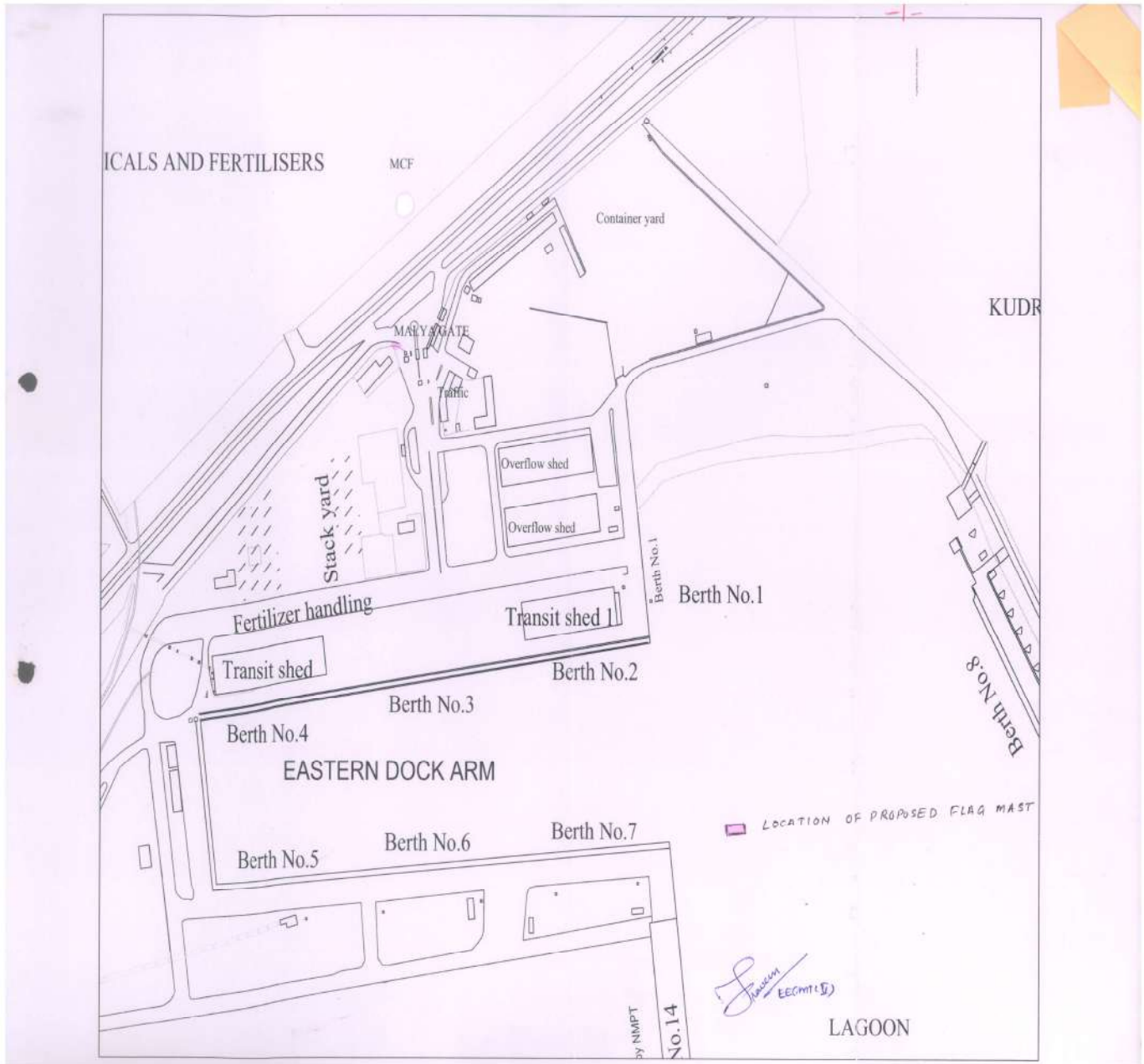

|   |           |                  |
|---|-----------|------------------|
| 1 | 22/105-LP | Location Drawing |
|---|-----------|------------------|

- 33 -

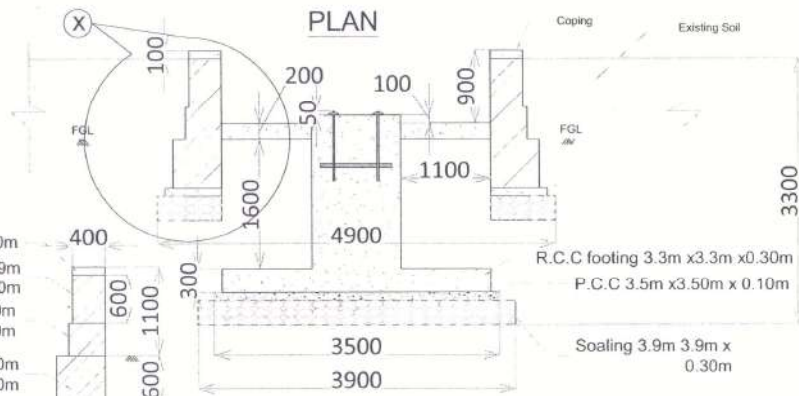
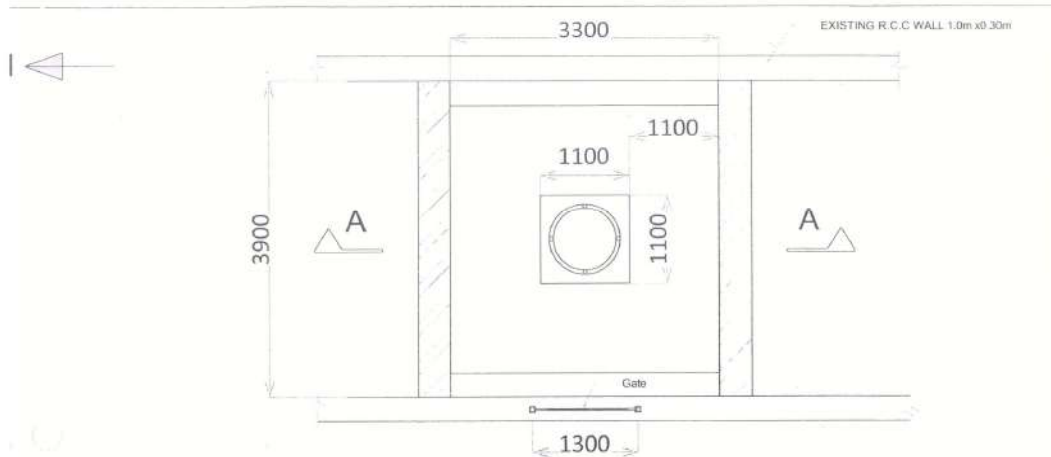

- Coping 3.9m x 0.40m x 0.10m
- Laterite Stone Masonry 3.9m x 0.70m x 0.40m
- Laterite Stone Masonry 3.9m x 0.450m x 0.40m
- Laterite Stone Masonry 3.9m x 0.60m x 0.60m
- P.C.C 3.9m x 0.70m x 0.10m
- Soaling 3.9m 0.80m x 0.30m

Detail-x



M.S Gate Detail

50 x 50 mm x 5mm M.S-SHS

100 x 100 mm x 5mm M.S-SHS

25 x 25 mm x 5mm M.S-SHS

|              |
|--------------|
| Anchor Bolts |
| 12Nos        |
| Dia-30mm     |
| Length-850mm |

|                                                                                                        |  |
|--------------------------------------------------------------------------------------------------------|--|
| <b>NEW MANGALORE PORT AUTHORITY</b>                                                                    |  |
| Name of Work:<br>Supply and Installation of Flag Mast near entrance gate at NMPA-Detail layout drawing |  |
| Drawing Number: 02                                                                                     |  |
| Drawn by: Dhananjay                                                                                    |  |

*ghs*  
28/02/23  
i.r.c.s

*Dhananjay*  
28/2/23

|   |           |           |
|---|-----------|-----------|
| 2 | 22/105-01 | Elevation |
|---|-----------|-----------|

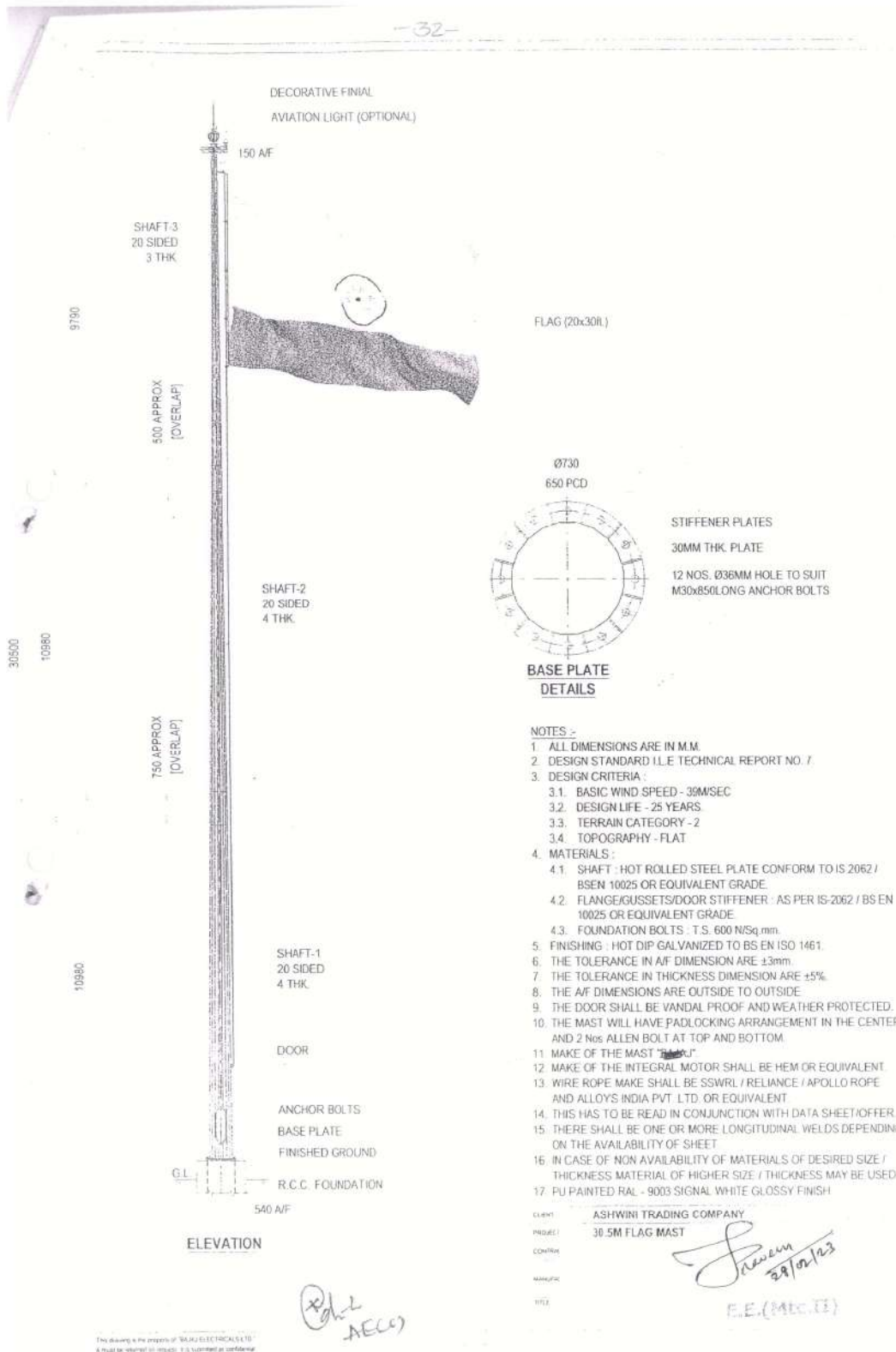

|   |           |                                |
|---|-----------|--------------------------------|
| 3 | 22/105-02 | Elevation & base plate details |
|---|-----------|--------------------------------|

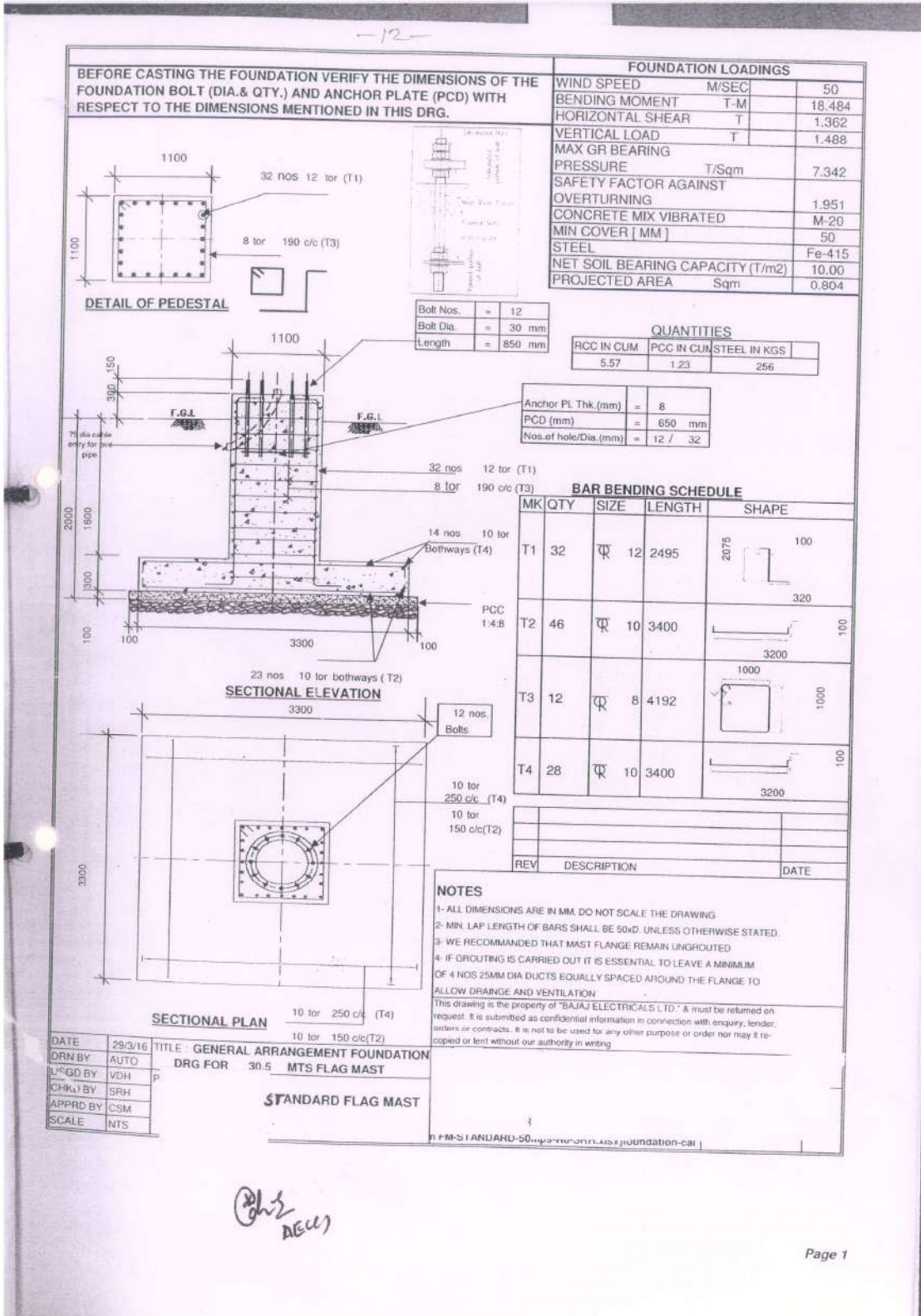

|   |           |                     |
|---|-----------|---------------------|
| 4 | 22/105-03 | Sectional Elevation |
|---|-----------|---------------------|



|   |           |    |
|---|-----------|----|
| 5 | 22/105-04 | 04 |
|---|-----------|----|



**NEW MANGALORE PORT AUTHORITY  
Panambur, Mangalore**

**SUPPLY AND INSTALLATION OF FLAG MAST  
NEAR ENTRANCE GATE AT NMPA**

**TENDER DOCUMENT  
Volume - III**

## Table of Contents

|                                          |            |
|------------------------------------------|------------|
| <b>SECTION VI</b> .....                  | <b>153</b> |
| (i) PREAMBLE TO BILL OF QUANTITIES ..... | 153        |
| 1. General Instructions .....            | 153        |
| 2. Civil Works .....                     | 156        |
| 3. Abbreviations .....                   | 158        |
| ii) BILL OF QUANTITIES .....             | 160        |
| (iii) FORM OF TENDER .....               | 167        |
| <b>SECTION VII</b> .....                 | <b>169</b> |
| SCHEDULE – B .....                       | 174        |



**VOLUME III****SECTION VI****(i) PREAMBLE TO BILL OF QUANTITIES****1. General Instructions****1.1 General**

- 1.1.1 This Bill of Quantities must be read with the Drawings, Conditions of Contract and the Specifications, and the Contractor shall be deemed to have examined the Drawings, Specifications, Conditions of Contract and to have acquainted himself with the detailed descriptions of the Works to be done, and the way in which they are to be carried out.
- 1.1.2 Notwithstanding that the work has been sectionalized every part of it shall be deemed to be supplementary to and complementary of every other part and shall be read with it or into it so far as it may practicable to do so.
- 1.1.3 The detailed descriptions of work and materials given in the Specifications are not necessarily being repeated in the Bill of Quantities.
- 1.1.4 The Contractor shall be deemed to have visited the Site before preparing his tender and to have examined for himself the conditions under which the work will proceed and all other matters affecting the carrying out of the works and cost thereof.
- 1.1.5 The Tenderer will be held to have familiarised himself with all local conditions, in so far as they affect the work, means of access and the locality of existing services, in order to execute the Works measured and described hereinafter. No claims for want of knowledge in this respect will be reimbursed.

**1.2 Rates and Prices to be Inclusive**

- 1.2.1 Rates and prices set against items are to be the all inclusive value of the finished work shown on the Drawings and/or described in the Specification or which can reasonably be inferred there from and are to cover the cost of provision of plant, labour, supervision, materials, test charges, freight,

transportation, erection, installation, performance of work, care of works, insurance, maintenance, overheads and profits and every incidental and contingent cost and charges whatsoever including all taxes if any excluding GST and every kind of temporary work executed or used in connection therewith (except those items in respect of which provision has been separately made in the general condition of contract) and all the Contractor's obligations under the Contract and all matters and things necessary for the proper completion and maintenance of the Works.

- 1.2.2 The rates and prices set down against the items are to be the full inclusive value of the finished work shown on the Drawing and/or described in the Specification or which can reasonably be inferred the reform and to cover the cost of every description of Temporary Works executed or used in connection therewith (except those items in respect of which specific provision has been separately made in these Bills of Quantities) and all the Contractor's obligations under the Contract including testing, giving samples and all matters and things necessary for the proper execution, completion and maintenance of the Works.
- 1.2.3 The Specifications are intended to cover the supply of material and the execution of all work necessary to complete the works. Should there be any details of construction or material which have not been referred to in the Specifications or in the Bill of Quantities and Drawings, but the necessity for which may reasonably be implied or inferred there from, or which are usual or essential to the completion of all works in all trades, the same shall be deemed to be included in the rates and prices entered in the Bill of Quantities. The rates and prices are to cover the item as described in the Bill of Quantities and if there is inconsistency in the description between the Bill of Quantities, Specifications or Drawings, the interpretation will be done according to General Conditions of Contract.
- 1.2.4 The quantities given in the Bill are approximate and are given to provide a common basis for tendering. They are not to be taken as a guarantee that the quantities scheduled will be carried out or required or that they will not be exceeded. The Employer / Engineer reserves the right to delete any item and / or increase / reduce quantities indicated in the Bills of Quantities at any

time. Payment will be made according to the actual quantities of work ordered and carried out in the contract. However, the rates quoted shall be valid for any extent of variation in quantity of each individual item provided that the total contract value does not get altered by more than indicated in conditions of contract. No claim whatsoever for extra payment due to variation of quantities within the above said limit would be entertained.

1.2.5 The drawings for tender purposes are indicative only of the work to be carried out. However, the Tenderer must allow within his price for the items of work included in the Tender Documents for the details which will appear on subsequent drawings developed for construction purposes. Rate and price shall include any additional design/ detailing to be carried out by contractor.

1.2.6 The rates and prices shall include (except where separate items are given) for the provision and operation of the following items, for compliance with the Conditions of Contract, Special Conditions, the specifications and Tender drawings:

- i) Supervision and labour for the Works;
- ii) All materials, installation/erection, handling and transportation;
- iii) All Contractor's Equipment;
- iv) All testing, commissioning, insurance, maintenance, security, welfare facilities, overheads and profit and every incidental and contingent costs and charges whatsoever including;
- v) All temporary fencing, watching, lighting, sanitary accommodation, general security arrangements, welfare facilities and first aid provision;
- vi) Provision and maintenance of Contractor's site offices, cabins, huts, maintenance and storage areas;
- vii) All taxes if any excluding GST on the transfer of property in goods in the execution of works, Excise Duty, Duties, etc. (other than Customs Duty for materials to be permanently incorporated into the Works);
- viii) All necessary temporary services including fresh water, compressed air lines, electrical cabling and switchgear, telephone, walkie-talkie and facsimile facilities;
- ix) The maintenance of all Contractor's services;
- x) All insurances for the Works;
- xi) Allowance for complying with all environmental aspects as specified;
- xii) Detail design of components of temporary works, wherever

necessary as directed by Engineer.

#### **1.4 Method of Measurement**

- 1.4.1 Measurement of Work shall be in accordance with IS 1200 and shall be net off the dimensions of the works shown on the drawings except as mentioned below:
- 1.4.2 Units of Measurement: The units of measurement used in this Bill of Quantities are in metric units as follows:
- i) Linear: Linear metre, centimeter or millimeter abbreviated to 'Rm', 'cm' or 'mm' respectively.
  - ii) Superficial: Square metre or Square centimeter abbreviated to 'Sq.M' or 'sq.cm' respectively.
  - iii) Volumetric: Cubic metre abbreviated to 'cu.m'. Litre abbreviated to 'L'
  - iv) Weight: Tonne = 1000 Kilograms, abbreviated to 'T', / 'MT' Kilogram abbreviated to 'kg'
  - v) Numbers: Numbers abbreviated to Nos. or No.
  - vi) Lump sum: Lump sum abbreviated to 'L.S.'

#### **1.5 Currency**

- 1.5.1 All monetary reference herein and the Bill of Quantities shall be priced in Indian Rupee Currency.

## **2. Civil Works**

- 2.2 Precast Concrete
- 2.2.1 Shuttering for precast concrete shall not be measured and paid for separately.
- 2.2.2 Effort for placement of precast concrete at the final locations shall not be measured unless a specific item is provided in the Bill of Quantities.
- 2.2.3 The precast concrete units shall be measured as shown on the detailed drawings.
- 2.3 In-situ Concrete
- 2.3.1 Shuttering for In-situ concrete shall not be measured and paid for separately.
- 2.3.2 No deduction will be made for chamfers smaller than 50 sq.cm. sectional area, reinforcement bolts and other embedded parts unless larger than 0.1 sq.m. sectional area and 0.03 cu.m. in volume. No extra volume will be measured for splays or fillets smaller than 50 sq.cm. sectional area.
- 2.3.3 The rates for reinforced concrete shall include for all batching, mixing, transporting, hoisting or lowering to any height / depth, placing in position and compaction in work of any sectional area or thickness including shuttering, forming necessary construction joints, shear keys and stop ends, and for curing

and protecting etc. all as specified.

- 2.3.4 The rates shall include for preparing construction joints, shear keys and surfaces against which next stage concrete is to be cast and building in fittings including pipes and bolts except where specifically billed separately. No separate payment will be made for making openings/pockets/pits of any size and shape. Where surfaces are to receive finishes the rates shall include for leaving the surface rough or for hacking and roughening the surface to form a key.
- 2.3.5 Unless otherwise noted, rates shall include for inserting pipes and other inserts in position accurately, concreting while they are in position and also for protecting the same as the work proceeds.
- 2.3.6 Unless otherwise noted, the rates for concrete items shall include for finishing the top surface to levels and slopes and surface finish as specified. Rates for concrete shall include for finishing the slab to specified slope towards drains, etc.
- 2.4 Reinforcement
  - 2.4.1 Steel reinforcement will be measured by weight and fixed in accordance with Drawings and Specifications. The weight of reinforcement bars -whether plain, deformed or ribbed etc., -of various diameters will be calculated in accordance with Table 1 of IS:1732 'Dimensions for Round and Square Steel Bars for Structural and General Engineering Purposes'.
  - 2.4.2 The rates shall include for laps, cutting and waste, straightening short and long lengths, bending, fixing, rolling margin and the provision of spacer bars or support, chairs, binding wire, saddles, forks and all dense concrete spacer blocks, etc., including preparing bending schedules from the Drawings.
  - 2.4.3 The rates shall include for all necessary descaling, wire brushing and cleaning to remove all rust and mill scale, dirt, grease and other deleterious matter before fixing and whilst still exposed during construction.
- 2.5 Structural and Miscellaneous Steel work
  - 2.5.1 Rates for structural steel work and iron work shall include supply, fabrication, delivery and erection/embedment in concrete at Site and all charges for welding, cutting, bending, bolting, site connections, fixing to foundations.
  - 2.5.2 The rates for Structural Steelwork shall include:
    - i) Supply, fabrication, delivery and erection
    - ii) Rolling margin, cutting and waste, weld metal, bolts, fixings and fittings

- iii) Hoisting, drilling, bolting or welding and fixing in the manner specified or indicated in the drawing
  - iv) Fabrication drawings
  - v) Welding trials and tests
  - vi) Erection trials
  - vii) Protective treatment (painting, hot dip galvanizing etc), including making good any damage if provided in the BOQ item.
- 2.5.3 Metalwork items are described in the Bills of Quantities and the Tenderer is to include for all the fittings, etc., described. All items shall include the necessary fabrication, joints, angles, intersections and ends, all bolts or fixing lugs, all hoisting and scaffolding required and casting in fixings or later cutting out or forming pockets for same, grouting, supporting and making good.
- 2.5.4 Rates are to include for all necessary scaffolding, working over water and at any height staging and hoisting and tarpaulin or other protective covers and the cleaning and removal of paint stains and spots, etc.
- 3.4.1 The Contractor's unit rates and prices shall include all equipment, apparatus, material indicated in the Drawings, and/or Specifications in connection with the item in question and also associated labour as well as all additional equipment, apparatus, material, consumables usually necessary to complete the system even though not specifically shown, described or otherwise referred to and also associated labour.
- 3.4.2 The rate for providing and fixing above items shall include all fittings, fixtures, base and sole plates, anchor bolts, including epoxy grouting, etc. all complete as specified, including the necessary additional supervision to ensure accurate alignment

### 3. Abbreviations

- 4.1.1 The following abbreviations are used in the Specifications and Bill of Quantities:

|         |                  |
|---------|------------------|
| IS :    | Indian Standard  |
| BS :    | British Standard |
| Qty. :  | Quantity         |
| mm :    | Millimeters      |
| cm :    | Centimeters      |
| M / m : | Meters           |
| LM :    | linear metre     |
| LS :    | lump sum         |
| Rs. :   | Rupees           |
| P. :    | Paise            |

|                              |                                                      |
|------------------------------|------------------------------------------------------|
| Nos. :                       | Numbers                                              |
| do :                         | Ditto                                                |
| MS :                         | mild steel                                           |
| T :                          | Tones                                                |
| Kg :                         | Kilogram                                             |
| EO :                         | Extra over (previous sum unless specified otherwise) |
| sq.m. /m <sup>2</sup> / sqmt | square metre                                         |
| sq.cm. :                     | square centimeters                                   |
| mm <sup>2</sup> :            | Square Millimetre                                    |
| Cu.m. / cum:                 | cubic meters                                         |
| YST :                        | yield stress                                         |
| dia :                        | Diameter                                             |
| wt. :                        | Weight                                               |
| Drg.No.:                     | drawing number                                       |
| max. :                       | Maximum                                              |
| min :                        | Minimum                                              |
| approx :                     | Approximately                                        |
| n.e.:                        | not exceeding                                        |
| incl:                        | Including                                            |
| circ:                        | Circular                                             |
| set :                        | set / sets                                           |
| c/c                          | centre to centre                                     |
| @ :                          | at the rate of                                       |
| Qtl                          | Quintal                                              |

## ii) BILL OF QUANTITIES

| NAME OF WORK: SUPPLY AND INSTALLATION OF FLAG MAST NEAR ENTRANCE GATE AT NMPA |                                                                                                                                                                                                                                                                                                                                                                                                                                                                                                                                                                         |        |      |                         |                  |
|-------------------------------------------------------------------------------|-------------------------------------------------------------------------------------------------------------------------------------------------------------------------------------------------------------------------------------------------------------------------------------------------------------------------------------------------------------------------------------------------------------------------------------------------------------------------------------------------------------------------------------------------------------------------|--------|------|-------------------------|------------------|
| Item No.                                                                      | DESCRIPTION OF ITEM                                                                                                                                                                                                                                                                                                                                                                                                                                                                                                                                                     | QTY    | UNIT | RATE IN figures / WORDS | AMOUNT (Rs. Ps.) |
| 1                                                                             | Clearing and grubbing road land including uprooting rank vegetation, grass, bushes, shrubs, saplings and trees girth up to 300mm, removal of stumps of trees cut earlier and disposal of unserviceable materials and stacking of serviceable material to be used or auctioned, including removal and disposal of top organic soil not exceeding 150 mm in thickness by mechanical means using dozer in area of light jungle.                                                                                                                                            | 0.0040 | Ha   | 1,58,044.00             | 632.18           |
| 2                                                                             | Cutting of trees of girth 300mm to 600mm including cutting of trunks, branches and removal of stumps stacking of serviceable materials with all lifts, earth filling in the depressions/pits complete as per specification. MORTH specification No.201                                                                                                                                                                                                                                                                                                                  | 3.00   | Each | 469.00                  | 1,407.00         |
| 3                                                                             | Demolishing R.C.C. work manually/ by mechanical means including stacking of steel bars and disposal of unserviceable material to the appropriate disposal area as per direction of Engineer-in-charge                                                                                                                                                                                                                                                                                                                                                                   | 0.55   | Cum  | 1,858.00                | 1,021.90         |
| 4                                                                             | Earth work excavation by manual means for drains, canals, waste weir, draft, approach channels, key trenches, foundation of bridges and such simillar works in all kinds of soils, as per drawing and technical specifications, including setting out, shoring, strutting, barricading, caution lights, removal of stumps and other deleterious matter, excavated surface leveled and sides neatly dressed disposing off the excavated stuff or sorting & stacking the selected stuff for reuse in a radius of 50 m and lift upto 1.5 m including cost of labour, tools | 65.00  | Cum  | 199.00                  | 12,935.00        |



|   |                                                                                                                                                                                                                                                                                                                                                                                                                                                                                                                                                                                                                                                                    |       |     |          |           |
|---|--------------------------------------------------------------------------------------------------------------------------------------------------------------------------------------------------------------------------------------------------------------------------------------------------------------------------------------------------------------------------------------------------------------------------------------------------------------------------------------------------------------------------------------------------------------------------------------------------------------------------------------------------------------------|-------|-----|----------|-----------|
|   | & other appurtenances required to complete the work. Depth exceeding 1.5m, but not exceeding 3 m                                                                                                                                                                                                                                                                                                                                                                                                                                                                                                                                                                   |       |     |          |           |
| 5 | Dismantling steel work in built up sections in angles, tees, flats and channels including all gusset plates, bolts, nuts, cutting rivets, welding etc. including dismembering and stacking to the appropriate disposal area as per direction of Engineer-in-charge.                                                                                                                                                                                                                                                                                                                                                                                                | 27.00 | kg  | 3.00     | 81.00     |
| 6 | Providing and Filling in foundation with granite / trap broken metal 100mm. and down size, with approved sand including hand packing, ramming, watering, including cost of all materials and labour with all lead and lift. complete as per specifications.                                                                                                                                                                                                                                                                                                                                                                                                        | 6.50  | Cum | 2,668.05 | 17,342.33 |
| 7 | Providing and laying in position plain cement concrete for levelling course for all works in foundation. The granite/trap/basalt crushed graded coarse aggregates and fine aggregates as per relevant IS Codes machine mixed, laid in layers not exceeding 150 mm thickness, well compacted using plate vibrators, including all lead & lifts, cost of all materials of quality, labour, Usage charges of machineries, curing, and all the other appurtenances required to complete the work as per technical specifications. (The cost of steel reinforcement shall be paid separately) Mix 1:3:6 (M10) Using 20 mm nominal size graded crushed coarse aggregates | 4.00  | Cum | 5,926.00 | 23,704.00 |
| 8 | Providing and constructing laterite size stone masonry in CM 1:6 including cost and conveyance of all materials, curing etc., complete as per specification. I.S. 3620/1979 having compressive strength not less than 3.5 N/mm <sup>2</sup> for saturated dry samples for foundation.                                                                                                                                                                                                                                                                                                                                                                              | 3.00  | Cum | 5,634.00 | 16,902.00 |

|    |                                                                                                                                                                                                                                                                                                                                                                                                                                                                                                                                                                                          |        |     |          |           |
|----|------------------------------------------------------------------------------------------------------------------------------------------------------------------------------------------------------------------------------------------------------------------------------------------------------------------------------------------------------------------------------------------------------------------------------------------------------------------------------------------------------------------------------------------------------------------------------------------|--------|-----|----------|-----------|
| 9  | Providing and constructing laterite size stone masonry in CM 1:6 including cost and conveyance of all materials, curing etc., complete as per specification. I.S. 3620/1979 having compressive strength not less than 3.5 N/mm <sup>2</sup> for saturated dry samples. For super structure                                                                                                                                                                                                                                                                                               | 4.00   | Cum | 5945.00  | 23,780.00 |
| 10 | Providing and laying in position plain cement concrete of mix 1:2:4 with cement @ 240kgs, with 20mm and down size graded granite metal coarse aggregates @ 0.69 cum and fine aggregates @ 0.459 cum, machine mixed, concrete laid in layers not exceeding 15 cms thick, well compacted, for coping. Including cost of all materials, labour, HOM, curing complete as per specifications.                                                                                                                                                                                                 | 0.50   | Cum | 5,759.00 | 2,879.50  |
| 11 | Providing Thermo Mechanically Treated bars of grade Fe-550 steel reinforcement for RCC work including straightening, cutting, bending, placing in position, binding and anchoring to adjacent members wherever necessary complete as per Design including cost of material, labour, usage charges complete as per specifications. (The laps and wastages shall not be measured separately)                                                                                                                                                                                               | 330.00 | Kg  | 88.00    | 29,040.00 |
| 12 | Providing and laying in position Reinforced cement concrete for all Sub structures of building, Irrigation works, Sub structure works of bridges, Drain works & other parallel works from 0.50m to 3.50m height. The granite /trap /basalt crushed graded coarse aggregates and fine aggregates as per relevant IS Codes, machine mixed with super plasticisers, laid in layers, well compacted using needle vibrators, providing weep holes wherever necessary, including all lead & lifts, cost of all materials of quality, centering, including shuttering, strutting, propping etc, | 6.50   | Cum | 6,613.95 | 42,990.68 |

|    |                                                                                                                                                                                                                                                                                                                                                                                                                                                                               |        |     |        |           |
|----|-------------------------------------------------------------------------------------------------------------------------------------------------------------------------------------------------------------------------------------------------------------------------------------------------------------------------------------------------------------------------------------------------------------------------------------------------------------------------------|--------|-----|--------|-----------|
|    | confirming to the requirements of relevant IS codes, labour, Usage charges of machinery, curing and all other appurtenances required to complete the work as per technical specifications. (The cost of steel reinforcement to be paid separately) M25 Design Mix Using 20mm nominal size graded crushed coarse aggregates.                                                                                                                                                   |        |     |        |           |
| 13 | Filling available excavated earth (excluding rock ) in sides of foundations upto plinth in layers not exceeding 20 cms. in depth, compacting each deposited layer by ramming after watering with lead upto 50 m. and lift upto 1.5 m. including cost of all labour complete as per specifications.                                                                                                                                                                            | 18.00  | Cum | 204.00 | 3,672.00  |
| 14 | Providing cement plastering 15mm thick in single coat with cement mortar to brick masonry including rounding of corners wherever required smooth rendering, providing and removing scaffolding, including cost of materials, labour, curing complete as per specifications. cement mortar 1:6                                                                                                                                                                                 | 12.00  | Sqm | 209.00 | 2,508.00  |
| 15 | Providing fabricating and erecting Mild Steel Square Hollow Section (SHS) for gate of approved make and quality as shown in the drawing including cost and conveyance of all materials, labour, cost of anchor plates, bolts, cutting, welding transportation etc fixing in position and applying a priming coat with two coats of paint including welding etc and usage charges of machinery complete as per specifications and as per directions of the Engineer-in-Charge. | 120.00 | Kg  | 155.00 | 18,600.00 |

|    |                                                                                                                                                                                                                                                                                                                                                                                                                                                                                                                                                                                                                                                                                                          |      |      |             |             |
|----|----------------------------------------------------------------------------------------------------------------------------------------------------------------------------------------------------------------------------------------------------------------------------------------------------------------------------------------------------------------------------------------------------------------------------------------------------------------------------------------------------------------------------------------------------------------------------------------------------------------------------------------------------------------------------------------------------------|------|------|-------------|-------------|
| 16 | Supply of 30.5 M high flag Mast. Mast shaft shall be in three sections, hot dip galvanised and suitable for wind velocity as per IS 875. It includes a special type of Dome. The shaft shall be PU painted with a coating of primer, and PU paint. It includes system for Raising Lowering of Flag. It shall have double drum winch, 6 mm dia stainless steel wire rope and integral power tool for the raising and lowering of Flag. Suitable control panel shall be provided for reversing operation of Power tool motor. Also includes LED aviation system with 3C x 2.5 Sqmm Cu armoured cable with earthing etc complete as per specifications and as per the directions of the Engineer In charge. | 1.00 | No   | 6,95,000.00 | 6,95,000.00 |
| 17 | Supply of foundation bolts manufactured from special steel along with nuts, washers, anchor plate and common template etc complete as per specifications and as per the directions of the Engineer In charge.                                                                                                                                                                                                                                                                                                                                                                                                                                                                                            | 1.00 | Set  | 24,000.00   | 24,000.00   |
| 18 | Supply of LED Aviation light and its fixing arrangement Complete set - Fiber Canopy as per specifications and as per the directions of the Engineer In charge                                                                                                                                                                                                                                                                                                                                                                                                                                                                                                                                            | 2.00 | No's | 21,500.00   | 43,000.00   |
| 19 | Supply of 350W LED flood lights Complete set                                                                                                                                                                                                                                                                                                                                                                                                                                                                                                                                                                                                                                                             | 4.00 | No's | 14,500.00   | 58,000.00   |
| 20 | Supply of 5m high Hot dip galvanised octagonal Pole suitable to mount one number flood light fitting at top including foundation bolts                                                                                                                                                                                                                                                                                                                                                                                                                                                                                                                                                                   | 4.00 | No's | 10,500.00   | 42,000.00   |
| 21 | Supply of good quality National flag of suitable material and of 30ft x 20ft size for 30.50 m high flag Mast as per specifications and as per the directions of the Engineer In charge.                                                                                                                                                                                                                                                                                                                                                                                                                                                                                                                  | 1.00 | No   | 65,000.00   | 65,000.00   |
| 22 | Erection of Flag Mast and Flag with the help of suitable equipments and assembly of operating system including                                                                                                                                                                                                                                                                                                                                                                                                                                                                                                                                                                                           | 1.00 | No   | 45,000.00   | 45,000.00   |

|    |                                                                                                                                                                                                                                                                                                                                                                                       |       |      |        |          |
|----|---------------------------------------------------------------------------------------------------------------------------------------------------------------------------------------------------------------------------------------------------------------------------------------------------------------------------------------------------------------------------------------|-------|------|--------|----------|
|    | commissioning of flag mast as per specifications and as per the directions of the Engineer In charge                                                                                                                                                                                                                                                                                  |       |      |        |          |
| 23 | Painting with synthetic enamel paint of approved brand and manufacture to give an even shade : Two coats on new work after thoroughly brooming the surface to remove all dirt, dust, mortar drops and foreign matter including preparing the surface even and sand paper smooth, cost of materials, labour complete as per specifications and as per directions of Engineer-in-charge | 24.00 | Sqm  | 90.00  | 2,160.00 |
| 24 | Supplying of 1.1 KV LT UG cable XLPE insulated, PVC extruded inner sheath armoured UG LT cable as per IS-7098 Part-1, Armouring strip thickness in average +5% and resistivity as per IS-3975. i) 3.5 core 25 sq.mm                                                                                                                                                                   | 50.00 | Mtrs | 182.00 | 9,100.00 |
| 25 | Labour charges for laying of 3.5 core 25 sq.mm size 1.1KV class XLPE UG cable/on wall/GI Pipe/HDPE pipe as required etc., complete.                                                                                                                                                                                                                                                   | 50.00 | Mtrs | 15.50  | 775.00   |
| 26 | Supplying and making end termination with metal glands, lugs of LT cable for 3.5 core 25 sq.mm.                                                                                                                                                                                                                                                                                       | 2.00  | Set  | 400.00 | 800.00   |
| 27 | Supplying and laying of 63 mm OD/50 mm ID as per IS 14930 part II double walled corrugated (DWC) HDPE Pipe including all necessary connecting sockets/ couplings/Tees /Bends/End-caps of same materials in existing trench suitable for drawing underground cables.                                                                                                                   | 50.00 | Mtrs | 90.00  | 4,500.00 |
| 28 | Digging of trench of 0.6 Meter deep x 0.3 Meter wide, refilling the trench to the required ground level and consolidating etc., complete. i) Hard Soil                                                                                                                                                                                                                                | 40.00 | Mtrs | 61.20  | 2,448.00 |
| 29 | Digging of trench of 0.6 Meter deep x 0.3 Meter wide, refilling the trench to the required ground level and consolidating etc., complete. i) C.C.Cutting                                                                                                                                                                                                                              | 6.00  | Mtrs | 123.00 | 738.00   |

|                             |                                                                                                      |       |      |        |                     |
|-----------------------------|------------------------------------------------------------------------------------------------------|-------|------|--------|---------------------|
| 30                          | Removal of pavement blocks and re-fixing to its original conditions for laying of cable as required. | 30.00 | Mtrs | 150.00 | 4,500.00            |
| <b>TOTAL Rs.</b>            |                                                                                                      |       |      |        | <b>11,94,516.59</b> |
| Excess/Less (In Percentage) |                                                                                                      |       |      |        |                     |
| Quoted Amount in Figures    |                                                                                                      |       |      |        |                     |

(Quoted amount in Words Rupees .....)

**Note:**

1. GST as applicable shall be claimed as separate line item in tax invoice and the same will be paid separately.
2. Contractor shall file the applicable returns with tax department in time and submit the same as documentary evidence.

**SIGNATURE OF THE BIDDER**

**(iii) FORM OF TENDER**

NAME OF CONTRACT.....

To

Executive Engineer (Civil)  
New Mangalore Port Trust  
Panambur  
Mangalore - 575 010

Sir,

1. We have examined the Conditions of Contract, Specification, Drawings, Bill of Quantities, and Addenda Nos----- for the execution of the above-named Works, and we the undersigned, offer to execute and complete such Works and remedy any defects therein in conformity with the Conditions of Contract, Specifications, Drawings and Bill of Quantities and Addenda
2. We acknowledge that the Appendix forms part of our Tender.
3. We undertake, if our Tender is accepted, to commence the Works as soon as is reasonably possible after the receipt of the Engineer's notice to commence, and to complete the whole of the Works comprised in the Contract within the time stated in the Appendix to Tender.
4. We agree to abide by this Tender for the period of 120 days from the last date fixed for receiving the same and it shall remain binding upon us and may be accepted at any time before the expiration of that period.
5. Unless and until a formal Agreement is prepared and executed, this Tender together with your written acceptance thereof shall constitute a binding Contract between us.
6. We understand that you are not bound to accept the lowest or any tender you may receive.

Dated this \_\_\_\_\_ day of \_\_\_\_\_ 201\_\_\_\_

Signature \_\_\_\_\_ in the Capacity of \_\_\_\_\_  
duly authorised to sign Tenders for and on behalf of \_\_\_\_\_

\_\_\_\_\_

(IN BLOCK LETTERS)

Address: \_\_\_\_\_  
\_\_\_\_\_  
\_\_\_\_\_  
\_\_\_\_\_

Witnesses

1. Signature : \_\_\_\_\_  
Name : \_\_\_\_\_  
Address : \_\_\_\_\_  
\_\_\_\_\_  
\_\_\_\_\_  
\_\_\_\_\_

2. Signature : \_\_\_\_\_  
Name : \_\_\_\_\_  
Address : \_\_\_\_\_  
\_\_\_\_\_  
\_\_\_\_\_  
\_\_\_\_\_



**SECTION VII**  
**SCHEDULE II**

(See sub rule (1) of Rule 36)

| SI. No. | Name of the Mineral                                                                                                                                                                                  | Present Rate of Royalty                                                                                               | Royalty to be revised |               |
|---------|------------------------------------------------------------------------------------------------------------------------------------------------------------------------------------------------------|-----------------------------------------------------------------------------------------------------------------------|-----------------------|---------------|
|         |                                                                                                                                                                                                      |                                                                                                                       | Export                | Domestic      |
| 1       | Ornamental and Decorative Building Stones as defined under clause(m) of Rule 2<br>A) Dyke Rock<br>(i) Black granites:<br>(a) Chamarajanagar District:                                                | 15% of Sale Value or of Average Selling Price on advalorem basis or Rs.4,500 per m <sup>3</sup> which is higher.      | Rs.1,200 per MT       | Rs.600 per MT |
|         | (b) All other Districts other than (a) above                                                                                                                                                         | 15% of Sale Value or of Average Selling Price on advalorem basis or Rs.1,500 per m <sup>3</sup> which is higher.      | Rs.1700 per MT        | Rs.400 per MT |
|         | (ii) Other varieties of dyke other than black granites (Entire State)                                                                                                                                | 15% of Sale Value or of Average Selling Price on advalorem basis or Rs.1,500 per m <sup>3</sup> which is higher.      | Rs.500 per MT         | Rs.375 per MT |
|         | (B)(I) Pink and Red Granites (Ilkal Pink Variety)<br>(i) Hungunda and Badami Taluk of Bagalkot District, Kustagi of Koppal District.                                                                 | 15% of Sale Value or of Average Selling Price on advalorem basis or Rs.1,200                                          | Rs.1,000 per MT       | Rs.400 per MT |
|         | (ii) Pink and Red Granites, Gneissess and their structural varieties (other than Ilkal Pink Variety)                                                                                                 | 15% of Sale Value or Average Selling Price on advalorem basis or Rs.1,800 Variety) per m <sup>3</sup> which is higher | Rs.600 per MT         | Rs.350 per MT |
|         | C) Grey and White Granites and their varieties:<br>(i) Very fine grained Grey granite (Sira grey Variety) Price on Chintanmi, Siddlaghattaof Chikkaballapura District Hoskote of Bangalore District. | 15% of Sale Value or of Average Selling Price on advalorem basis or Rs.1,350 per m <sup>3</sup> which is higher.      | Rs.500 per MT         | Rs.350 per MT |

|    |                                                                                                                                        |                                                                                                                  |                                        |               |
|----|----------------------------------------------------------------------------------------------------------------------------------------|------------------------------------------------------------------------------------------------------------------|----------------------------------------|---------------|
|    | (ii) Grey and white granites and textural varieties having shades of grey, black and white colours (other than (i) above Entire State. | 15% of Sale Value or of Average Selling Price on advalorem basis or Rs.1,050 per m <sup>3</sup> which is higher. | Rs.375 per MT                          | Rs.250 per MT |
|    | (iii) Grey granite of Devanahalli Taluk of Bangalore Rural District and Chikkaballapur taluk of Chikkaballapur District                | 15% of Sale Value or of Average Selling Price on advalorem basis or Rs.600 per m <sup>3</sup> which is higher.   | Rs.300 per MT                          | Rs.200 per MT |
| 2  | Felsite and its varieties suitable for use as Ornamental Stone-Entire State                                                            | 15% of Sale Value or of Average Selling Price on advalorem basis or Rs.1800 per m <sup>3</sup> which is higher.  | Rs.900 per MT                          |               |
| 3  | Quartzite and sand stone and their varieties suitable for use as Ornamental Stone-Entire State                                         | 15% of Sale Value or of Average Selling Price on advalorem basis or Rs.1800 per m <sup>3</sup> which is higher.  | Rs.900 per MT                          |               |
| 4  | Marable and Crystalline Limestone as ornamental Stone-Entire State                                                                     | 15% of Sale Value or of Average Selling Price on advalorem basis or Rs.1800 per m <sup>3</sup> which is higher.  | Rs.1000 per MT                         |               |
| 5  | Bentonite-Entire State                                                                                                                 | Rs.400 per MT                                                                                                    | Rs.500 per MT                          |               |
| 6  | Fuller Earth-Entire State                                                                                                              | Rs.125 per MT                                                                                                    | Rs.125 per MT                          |               |
| 7  | Buff colour (waste) the permits not exceed 20% of permit issued For Fullers Earth                                                      | Rs.60 per MT                                                                                                     | Rs.70 per MT                           |               |
| 8  | Limestone under the title "Shahabad Stone"                                                                                             | Rs.70 per 10 Sq meters or Rs.70 per MT                                                                           | Rs.50 per 10 Sq meters or Rs.50 per MT |               |
| 9  | Limestone(non-cement) when used for building stone-Entire State                                                                        | Rs.25 per MT                                                                                                     | Rs.60 per MT                           |               |
| 10 | Ordinary Building Stone(Entire State as                                                                                                | Rs.60 per MT                                                                                                     | Rs.70 per MT                           |               |

|    |                                                                                                                                                                      |                                                                                        |            |
|----|----------------------------------------------------------------------------------------------------------------------------------------------------------------------|----------------------------------------------------------------------------------------|------------|
|    | defined under clause(g) of Rule2(1)                                                                                                                                  |                                                                                        |            |
| 11 | Limeshell-Entire State                                                                                                                                               | 100 per MT                                                                             | 120 per MT |
| 12 | Lime Kankar (non cement) Entire State                                                                                                                                | 50 per MT                                                                              | 80 per MT  |
| 13 | Agate, Chalcedony, Flint-Entire State                                                                                                                                | 240 per MT                                                                             | 300 per MT |
| 14 | Ordinary Sand-Entire State                                                                                                                                           | 60 Per MT                                                                              | 80 Per MT  |
| 15 | Steatite and sand stone used formakinghousehold utensils / articles-Entire State.                                                                                    | 40 Per MT                                                                              | 80 Per MT  |
| 16 | (i)Murram (All types of soils)-Entire State                                                                                                                          | 20 per MT                                                                              | 40 per MT  |
|    | (ii)Clay used for manufacturing tile sand bricks                                                                                                                     | 40 per MT                                                                              | 60 per MT  |
| 17 | Waste rocks generated in ornamental stone quarry-which is suitable for ornamental purpose Entire State (See explanation under Rule36)                                | 300 per MT or 850 CUM                                                                  | 300perMT   |
| 18 | Irregular shaped waste rock generated in Ornamental stone quarry, which is not suitable for ornamental purpose (used for making aggregates and m-sand) Entire State. | 60 per MT                                                                              | 40 per MT  |
| 19 | Waste rocks generated in Shahabad stone quarry-Entire State (See explanation under Rule-36)                                                                          | 60 per MT                                                                              | 40 per MT  |
| 20 | Finished Kerb stones/cubes not exceeding 30 cms each face-Entire State.                                                                                              | 110per MT                                                                              | 150 per MT |
| 21 | Barytes                                                                                                                                                              | 6.5% of average selling price or of sale value whichever is higher on ad-valorem basis | 400 per MT |
|    | (i) A Grade (Grey colour)                                                                                                                                            |                                                                                        | 300 per MT |
|    | (ii) B Grade (Grey colour)                                                                                                                                           |                                                                                        | 200 per MT |
|    | (iii) C, D Grade &Waste                                                                                                                                              |                                                                                        |            |
| 22 | Calcite                                                                                                                                                              | 15% of average selling price or of sale value whichever is higher on ad-valorem basis  | 80 per MT  |
| 23 | China clay and Kaolin (including Ball clay, White shell, Fireclay and white clay)                                                                                    | 8% of average selling price                                                            | 80 Per MT  |
|    | i)Crude/Raw                                                                                                                                                          |                                                                                        |            |

|    |                                                                                                                                                               |                                                                                                                                                        |                                                                                    |
|----|---------------------------------------------------------------------------------------------------------------------------------------------------------------|--------------------------------------------------------------------------------------------------------------------------------------------------------|------------------------------------------------------------------------------------|
|    | ii) Processed                                                                                                                                                 | or of sale value whichever is higher on ad-valorem basis.<br><br>12% of average selling price or of sale value whichever is higher on ad-valorem basis | 600 per MT                                                                         |
| 24 | Corundum                                                                                                                                                      | 12% of average selling price or of sale value whichever is higher on ad-valorem basis                                                                  | 15% of Sale Value or of Average Selling Price on ad valorem basis which is higher. |
| 25 | Dolomite                                                                                                                                                      | Rs.75 per MT                                                                                                                                           | 100 per MT                                                                         |
| 26 | Dunite and Pyroxenite                                                                                                                                         | Rs. 30 per MT                                                                                                                                          | 60 per MT                                                                          |
| 27 | Felsite (Other than for ornamental purpose)                                                                                                                   | 12% of average selling price or of sale value whichever is higher on ad-valorem basis                                                                  | 120 per MT                                                                         |
| 28 | Gypsum                                                                                                                                                        | 20% of average selling price or of sale value whichever is higher on ad-valorem basis                                                                  | 150 per MT                                                                         |
| 29 | Jasper                                                                                                                                                        | 12% of average selling price or of sale value whichever is higher on ad-valorem basis                                                                  | 150 per MT                                                                         |
| 30 | Quartz, feldspar                                                                                                                                              | 15% of average selling price or of sale value whichever is higher on ad-valorem basis                                                                  | 100 per MT                                                                         |
| 31 | Mica<br>i. Crude<br>ii. Waste                                                                                                                                 | 4% of average selling price or of sale value whichever is higher on ad-valorem basis                                                                   | 1500 per MT<br>500 per MT                                                          |
| 32 | Quartzite & Fuchsite<br>Quartzite not suitable for use as Ornamental /Gemstones                                                                               | 12% of average selling price or of sale value whichever is higher on ad-valorem basis                                                                  | 100 per MT                                                                         |
| 33 | Laterite<br>i) /dispatched for use in cement or chemical industries or Abrasive or Refractory purpose (below threshold value as specified by IBM from time to | Rs.60 per MT                                                                                                                                           | 160 per MT                                                                         |

|    |                                                                                    |                                                                                       |                                                                                    |
|----|------------------------------------------------------------------------------------|---------------------------------------------------------------------------------------|------------------------------------------------------------------------------------|
|    | time)<br>ii) For use as building stone (below threshold value as specified by IBM) |                                                                                       | 60 per MT                                                                          |
| 34 | Ochre                                                                              | Rs.24 per MT                                                                          | 60 per MT                                                                          |
| 35 | Pyrophyllite                                                                       | 20% of average selling price or of sale value whichever is higher on ad-valorem basis | 200 per MT                                                                         |
| 36 | Shale                                                                              | Rs.60 per MT                                                                          | 150 per MT                                                                         |
| 37 | Slate                                                                              | Rs.45 per MT                                                                          | 150 per MT                                                                         |
| 38 | Silica Sand                                                                        | 10% of average selling price or of sale value whichever is higher on ad-valorem basis | 100 per MT                                                                         |
| 39 | Steatite or Soapstone (Other than for household articles)                          | 18% of average selling price or of sale value whichever is higher on ad-valorem basis | 200perMT                                                                           |
|    | Talc                                                                               | --                                                                                    | 200perMT                                                                           |
| 40 | All other minerals (which is not specified in schedule-II) Entire State            | 30% of sale value on ad-valorem basis                                                 | 30% of Sale Value or of Average Selling Price on ad-valorem basis which is higher. |

\_\_\$\*\*\*\*\_\_\$

**SECTION VII****SCHEDULE – B****MINIMUM RATES OF WAGES****ABSTRACT OF MINIMUM RATES OF WAGES FROM RELEVANT NOTIFICATIONS**

MINIMUM RATES OF WAGES APPLICABLE IN THE BEAT OF ALC(C), MANGALORE WITH EFFECT FROM **01.04.2023**

Minimum Wages applicable "Construction or maintenance of roads, runways or in building operations including laying down underground electric, wireless, radio, television, telephone and overseas communication cables and similar other underground cabling work, electric lines, water supply lines and sewerage pipelines"-

| <b>Category</b>                       |         |        |        |
|---------------------------------------|---------|--------|--------|
|                                       | Area: A | Area:B | Area:C |
| Unskilled                             | 736.00  | 616.00 | 494.00 |
| Semiskilled/<br>Unskilled Supervisory | 816.00  | 695.00 | 577.00 |
| Skilled/Clerical                      | 897.00  | 816.00 | 695.00 |
| Highly Skilled                        | 973.00  | 897.00 | 816.00 |

(Kindly Note: Area A: Bangalore (UA), Area B: Mangalore (UA), Mysore (UA), Belgaum (UA), Hubli-Dharwad, Area C: All other places in Karnataka not specified above as per Ministry of Labour and Employment F.No.1/5 (3)/2023-LS-II dated 03.04.2023.)

"Employment of Sweeping and Cleaning excluding activities prohibited under the Employment of Manual Scavengers and Construction of Dry latrines (Prohibition) Act, 1933".

| <b>Area</b> | <b>Rates of wages Rs.</b> |
|-------------|---------------------------|
| 'A'         | 736.00                    |
| 'B'         | 616.00                    |
| 'C'         | 494.00                    |

"Employment of Watch and Ward"-Rates of wages for employees employed in watch and ward – Govt. of India, Ministry of Labour

|             | <b>Without arms</b>      | <b>With arms</b>         |
|-------------|--------------------------|--------------------------|
| <b>Area</b> | <b>Rates of wagesRs.</b> | <b>Rates of wagesRs.</b> |
| 'A'         | 897.00                   | 973.00                   |
| 'B'         | 816.00                   | 897.00                   |
| 'C'         | 695.00                   | 816.00                   |

For further details log on to Ministry of Employment