



TENDER DOCUMENT
NEW MANGALORE PORT AUTHORITY

CIVIL ENGINEERING DEPARTMENT

NIT No. CIVIL/CE(C)/EE(C)/54/2024-25

E-Tender ID NMPT/2024_NMPT_833734_1

Tender for

“PROVIDING M30 GRADE CONCRETE FOR REMAINING PORTION OF
BERTH NO. 2 INSIDE WHARF AREA”

THROUGH E-TENDERING MODE

Tender Amount	:	Rs. 83,13,722/-
E.M.D.	:	Rs. 1,96,300/-
Tender Fee	:	Rs. 1,120/- (Including GST @ 12%)



TENDER DOCUMENT
NEW MANGALORE PORT AUTHORITY
CIVIL ENGINEERING DEPARTMENT

Tender for

“PROVIDING M30 GRADE CONCRETE FOR REMAINING PORTION OF BERTH
NO. 2 INSIDE WHARF AREA”

Volume - 1

Table of Contents

i) NOTICE INVITING TENDER.....	9
ii) INSTRUCTIONS TO TENDERERS.....	13
A. Instructions for E-Tendering	13
B. Instructions To Tenderers (General).....	17
1. Introduction:	17
2. Applicants:	17
3. Invitation for Bids:.....	17
4. Purchase of Tender Documents:.....	17
5. One Bid per Bidder:.....	17
6. Cost of Bidding:.....	18
7. Site visit:.....	18
8. Content of Bidding Documents:.....	18
9. Clarification of the Bidding Documents:.....	18
10. Amendment of Bidding Documents:	19
11. Preparation of bids:	19
12. Minimum Eligibility Criteria:	19
13. Bid Prices:.....	21
14. Currencies of Bid and Payment:	21
15. Bid Validity:	21
16. Bid Security / EMD:	21
17. No Alternative Proposals by Bidders:	22
18. Format and Signing of Bid:	22
19. Bid Submission:	22
20. Deadline for Submission of the Bids:.....	24
21. Late Bids:	24
22. Modification and Withdrawal of Bids:.....	24
23. Bid Opening - Technical Bid:	25
24. Bid Opening – Financial Bid:	25

25.	Clarification of Bids:.....	25
26.	Examination of Bids and Determination of Responsiveness:.....	26
27.	Correction of Errors: (Not Applicable).....	26
28.	Evaluation and Comparison of Bids:.....	26
29.	Alteration of tender documents:.....	26
30.	Alternative conditions and Proposal:	27
31.	Award of Contract:	27
32.	Notification of Award:	27
33.	Release of Bid Security/EMD:	27
34.	Performance Security:.....	28
35.	Fraud and Corrupt Practices:	28
36.	Rejection of Tender:.....	29
37.	Additional Information:.....	29
38.	Compliance of Local Content as per Make in India Policy:	29
	Annexure – 1	30
	Annexure – 2.....	31
	Annexure – 3.....	33
	Annexure – 4.....	34
	Annexure – 5.....	35
	Annexure – 6.....	36
	Annexure – 6A (Not applicable).....	37
	Annexure – 7.....	38
	Annexure – 8.....	39
	Annexure-9.....	41
	Annexure-10.....	43
	Annexure-11.....	44
	Annexure 12.....	45
	Annexure-13	47
	Annexure-14.....	48
	SECTION - II.....	49
	iii) FORM OF AGREEMENT	49

SECTION - III	51
iv) CONDITIONS OF CONTRACT	51
A. General	51
1. Definitions	51
2. Interpretation	52
3. Language and Law	53
4. Engineer or his nominee's Decisions	53
5. Delegation	53
6. Communications	53
7. Contract Agreement	53
8. Subcontracting	54
9. Personnel	54
10. Employer's and Contractor's Risks	54
11. Employer's Risks	54
12. Contractor's Risks	55
13. Insurance	55
14. Site Investigation Reports	56
15. Queries about the Contract Data	56
16. Contractor to Construct the Works	56
17. The Works to Be Completed by the Intended Completion Date	56
18. Approval by the Engineer or his nominee	56
19. Safety	56
20. Discoveries	57
21. Possession of the Site	57
22. Access to the Site	57
23. Instructions	57
24. Disputes	57
25. Settlement of Disputes	57
25.1 Amicable Settlement/ Conciliation and Settlement Committee	57
26. Replacement of conciliator (deleted)	59
B. TIME CONTROL	60

27.	Program	60
28.	Revised Program	60
29.	Extension of the Intended Completion Date	60
30.	Delays Ordered by the Engineer or his nominee	61
31.	Management Meetings.....	61
32.	Early Warning.....	61
C.	QUALITY CONTROL	62
33.	Identify Defects	62
34.	Tests	62
35.	Defect Liability.....	62
36.	Uncorrected Defects.....	63
D.	COST CONTROL.....	64
37.	Bill of Quantities	64
38.	Changes in the Quantities	64
39.	Variations	64
40.	Payments for Variations	65
41.	Cash flow forecasts	66
42.	Payment Certificates	66
43.	Payments	67
44.	Compensation Events	68
45.	Tax.....	69
46.	Currencies.....	69
47.	Price Adjustment. (Not Applicable).....	69
48.	Retention.....	69
49.	Liquidated Damages	69
50.	Nominated Subcontractors.....	70
51.	Advance payment (Not Applicable)	70
52.	Securities	71
53.	Removal of Craft or Plant which has sunk (not applicable).....	71
54.	Cost of Repairs	72
E.	Finishing The Contract	73

55.	Completion	73
56.	Taking Over	73
57.	Final Account	74
58.	Submission of 'As built Drawings'	74
59.	Termination	74
60.	Payment upon Termination	76
61.	Property	76
62.	Release from Performance.....	76
F.	SPECIAL CONDITIONS OF CONTRACT	77
63.	Labour.....	77
64.	Compliance with labour regulations.....	77
65.	Safety, Security and Protection of the Environment.....	78
66.	Insurance of Works and Contractor's Equipment.....	78
67.	War Risks Insurance	79
68.	Royalty	79
69.	Transport of Contractor's Equipment or Temporary Works.....	80
70.	Transport of Materials or Plant	80
71.	Labor Laws & Regulations.....	80
72.	Life Saving Appliances and First Aid	83
73.	Diving Operations (NA)	84
74.	Bribes.....	84
75.	Details to be Confidential	84
76.	Contractor's Temporary works, office, etc.	84
77.	Water Supply.....	85
78.	Power Supply.....	85
79.	Taxes and Duties	86
80.	Price Adjustment (not applicable to this contract).....	87
81.	Noise and Disturbance	87
82.	Safety Code	87
83.	Port Authority Rules	88
84.	Execution of work.....	88

85.	Customs Duty.....	88
86.	Drawings & Designs (Not applicable to this contract)	90
87.	Monsoon Period	91
88.	Progress Report	91
89.	Completion Documents (not applicable).....	92
90.	Submission of statutory documents.....	92
G.	SALIENT FEATURES OF SOME MAJOR LAWS APPLICABLE TO ESTABLISHMENTS ENGAGED IN CONSTRUCTION WORK	93
v)	CONTRACT DATA	95
vi)	FORM OF SECURITIES	99
	Annexure A	100
	Annexure B (NA).....	102
	Annexure – C (NA).....	104
	Appendix 1 TO General conditions of contract (NA).....	106

NEW MANGALORE PORT AUTHORITY

PANAMBUR, MANGALORE -575010

NIT No: CIVIL/CE(C)/EE(C)/54/2024-25 Date: 06-11-2024

NOTICE INVITING TENDER

(Through E-Procurement only)

E-Tenders are invited by New Mangalore Port Authority, Panambur, Mangalore- 575010 through <https://www.eprocure.gov.in/eprocure/app> of CPP portal from the Contractor fulfilling the Minimum Eligibility Criteria stipulated in this notice in two cover bidding procedure for the work of "Providing M30 grade concrete for Remaining Portion of Berth No. 2 inside wharf area"

Minimum Eligibility Criteria:-

a) The tenderers must have experience of having successfully or substantially completed *similar works during last 7 (seven) years ending last day of month previous to the one in which applications are invited shall be either of the following

At least Three similar completed works costing not less than the amount

Rs.33.25lakhs each(Excluding GST)

or

At least Two similar completed works costing not less than the amount equal to

Rs.41.56lakhs each(Excluding GST)

or

At least One similar completed works costing not less than the amount equal to

Rs.66.50lakhs(Excluding GST)

The tenderers must have executed **key element** of work i.e "Cement concrete pavement or Reinforced cement concrete pavement with **M30 or M40 grade** of concrete" not less than **250 Cum** in total among the work / works considered for eligible assignment.

Note 1: *Similar work(s) means "**Construction / Improvement of road or open yard or platform with cement concrete pavement or Reinforced cement concrete pavement of M30 or M40 grade including allied works**".

Note 2: Documentary evidence for successful / substantial completion of the work shall be furnished along with work order and work completion certificate.

Note 3: Substantial completion shall be based on 80 (eighty) per cent (value wise) or more works completed under the contract. Certificate for 'substantial completion' of project/work/asset should contain two parts. Part -I shall contain 'financial value of work done' and part-II shall contain 'certificate of functional completion of project/work/asset'.

Note 4: The value of executed works shall be brought to current costing level by enhancing the actual value of the work upon completion by using the following

enhancement factors. For intermediate periods, the actual number of years will be calculated based on number of days and the enhancement / multiplying factor will be interpolated accordingly and the same will be considered for evaluation.

Year before	Enhancement / Multiplying factor
0	0
One year	1.07
Two years	1.14
Three years	1.21
Four years	1.28
Five years	1.35
Six years	1.42

- b) Average Financial turnover of the tenderer over the last three financial years 2021-22, 2022-23 & 2023-24 shall be at least Rs.24.95 lakhs.

The financial capacity of bidders would be evaluated considering the works in hand at NMPA on the due date of submission of bid. The port would deduct the turnover required for execution of work in hand at NMPA from the average financial turnover of the bidder. The remaining net financial turnover of the bidder will be considered for eligibility criteria.

The financial capacity to be 3.33times of the average financial turnover of last three years of the bidder minus works in hand at NMPA. The bidder must fill the annexure-6.

In case the average turnover is Rs. 3.00 crores, the financial capacity of the contractor will considered as (3x3.333) Rs.10.00crores.

The turnover means sales/ contract receipts excluding taxes other income shall not be considered for calculation of turnover

- c) The tenderer shall submit a copy of valid ESIC & EPF registration certificate along with the tender.

Pertinent information is given in the following table:

i)	Estimated Amount put to Tender	Rs 83,13,722/-
ii)	Earnest Money Deposit (EMD)	Rs. 1,96,300/- (Rupees One Lakh Ninety Six Thousand Three Hundred Only.) The EMD shall be in the form of Insurance Surety Bonds, Account Payee Demand draft, Fixed Deposit Receipt, Bankers Cheque or shall be paid by RTGS in favour of F.A. & C.A.O., NMPA. Scanned copy should be uploaded along with bid. The benefit of Exemption of EMD to all Micro and small enterprises (MSE) will allowed. Shall upload with their offer, the proof of their being MSE registered with

		district industries center (DIC) or Khadhi and village industries commission or Khadhi and Industries board (KVIV) or Coir board or National Small Industries Corporation (NSIC) or Directorate of handicrafts and handlooms or Udyam Registration Certificate or any other body specified by Ministry of MSME. The bidder shall submit "Bid Security Declaration" in the prescribed form as per Annexure 13.
iii)	Cost of Tender (Tender fee)	Rs. 1120/- (Rupees One Thousand One Hundred Twenty Only) Payment of Tender fee by NEFT in favour of F.A. & C.A.O., NMPA. Scanned copy should be uploaded along with bid. Scanned copy should be uploaded along with bid. The benefit of Exemption of Tender fee to Micro and small enterprises (MSE) will allowed. Shall upload with their offer, the proof of their being MSE registered with district industries center (DIC) or Khadhi and village industries commission or Khadhi and Industries board (KVIV) or Coir board or National Small Industries Corporation (NSIC) or Directorate of handicrafts and handlooms or Udyam Registration Certificate or any other body specified by Ministry of MSME.
iv)	Document download start date and time	06-11-2024
v)	Seek clarification start date and time	NA
vi)	Seek clarification end date and time	NA
vii)	Bid submission start date and time	20-11-2024
vii)	Bid submission closing date and time	27-11-2024
ix)	Date & time of opening of Cover -I : Technical Part - II : Financial	28-11-2024 Shall be communicated separately.

x)	Completion period	6 (Six) Months Including monsoon
xi)	Validity of Tender	90 days from the date of closing of online submission of e-tender.

Tenderer shall have to pay the prescribed cost of tender i.e., Rs. 1120/- (Rupees One Thousand One Hundred Twenty Only) by NEFT in favour of F.A. & C.A.O., NMPA.

NMPA Bank Details.

1. Name of the Bank: State Bank of India, Panambur, Mangalore - 575 010.

2. Bank A/C No. 10205649448

3. IFSC Code: SBIN0002249

4. MICR Code: 575002011

Contact Nos. 0824-2887306 / 0824-2887308

Email id: bhagyalaxmi.b@nmpt.gov.in / chiefengineer@nmpt.gov.in

Amendments / further information etc. pertaining to the tender, if any shall be uploaded only on websites <https://www.eprocure.gov.in/eprocure/app> of CPP portal, may have to be referred by the prospective Tenderer from time to time.

-sd-

Executive Engineer (Civil)

NEW MANGALORE PORT AUTHORITY
PANAMBUR, MANGALORE -575010
NIT No: CIVIL/CE(C)/EE(C)/54/2024-25
E-Tender event No. 2024_NMPT_833734_1

i) INSTRUCTIONS TO TENDERERS

A. Instructions for E-Tendering

INSTRUCTION TO E-TENDERING

1. SPECIAL INSTRUCTIONS TO THE BIDDERS FOR THE E-SUBMISSION OF THE BIDS ONLINE THROUGH THIS E-PROCUREMENT PORTAL

This is an e-procurement event of NMPA. The e-procurement service provider is <https://www.eprocure.gov.in/eprocure/app> of CPP portal. You are requested to read the terms & conditions of this tender before submitting your online tender. Tenderers who do not comply with the conditions with documentary proof (wherever required) will not qualify in the Tender.

1. Bidder should do Online Enrolment in the Portal using the option Click Here to Enroll available in the Home Page. Then the Digital Signature enrollment has to be done with the e-token, after logging into the portal.
2. Bidder then logs into the portal giving user id / password chosen during enrollment.
3. The e-token that is registered should be used by the bidder and should not be misused by others.
4. DSC once mapped to an account cannot be remapped to any other account. It can only be inactivated.
5. The Bidders can update well in advance, the documents such as certificates, purchase order details etc., under My Documents option and these can be selected as per tender requirements and then attached along with bid documents during bid submission. This will ensure lesser upload of bid documents.
6. After downloading / getting the tender schedules, the Bidder should go through them carefully and then submit the documents as per the tender document; otherwise, the bid will be rejected.
7. The BOQ template must not be modified/replaced by the bidder and the same should be uploaded after filling the relevant columns, else the bidder is liable to be rejected for that tender. Bidders are allowed to enter the Bidder Name and Values only.
8. If there are any clarifications, this may be obtained online through the e-Procurement Portal, or through the contact details given in the tender document. Bidder should take into account of the corrigendum published before submitting the bids online on the portal or on www.newmangaloreport.gov.in Bidder, in

advance, should prepare the bid documents to be submitted as indicated in the tender schedule and they should be in PDF formats.

9. Bidder should arrange for the EMD and tender fee as specified in the tender. The benefit of Exemption of EMD to all Micro and small enterprises (MSE) will allowed. Bidder Shall upload with their offer, the proof of their being MSE registered with district industries center (DIC) or Khadhi and village industries commission or Khadhi and Industries board (KVIV) or Coir board or National Small Industries Corporation (NSIC) or Directorate of handicrafts and handlooms or Udyam Registration Certificate or any other body specified by Ministry of MSME will be considered. The bidder should read the terms and conditions and accepts the same to proceed further to submit the bids.
10. The bidder has to submit the tender document(s) online well in advance before the prescribed time to avoid any delay or problem during the bid submission process.
11. There is no limit on the size of the file uploaded at the server end. However, the upload is decided on the Memory available at the Client System as well as the Network bandwidth available at the client side at that point of time. In order to reduce the file size, bidders are suggested to scan the documents in 75-100 DPI so that the clarity is maintained and the size of file gets reduced. This will help in quick uploading even at very low bandwidth speeds.
12. It is important to note that, the bidder has to click on the Freeze Bid Button, to ensure that, he/she completes the Bid Submission Process. Bids, which are not frozen, are considered as Incomplete/Invalid bids and are not considered for evaluation purposes.
13. The Tender Inviting Authority (TIA) will not be held responsible for any sort of delay or the difficulties faced during the submission of bids online by the bidders due to local issues.
14. The bidder may submit the bid documents online mode only, through this portal. Offline documents will not be handled through this system.
15. At the time of freezing the bid, the e-Procurement system will give a successful bid updating message after uploading all the bid documents submitted and then a bid summary will be shown with the bid no., date & time of submission of the bid with all other relevant details. The documents submitted by the bidders will be digitally signed using the e-token of the bidder and then submitted.
16. After the bid submission, the bid summary has to be printed and kept as an acknowledgement as a token of the submission of the bid. The bid summary will act as a proof of bid submission for a tender floated and will also act as an entry point to participate in the bid opening event.
17. Successful bid submission from the system means, the bids as uploaded by the bidder is received and stored in the system. System does not certify for its correctness.

18. The bidder should see that the bid documents submitted should be free from virus and if the documents could not be opened, due to virus, during tender opening, the bid is liable to be rejected.
19. The time that is displayed from the server clock at the top of the tender Portal, will be valid for all actions of requesting bid submission, bid opening etc., in the e-Procurement portal. The Time followed in this portal is as per Indian Standard Time (IST) which is GMT+5:30. The bidders should adhere to this time during bid submission.
20. The bidders are requested to submit the bids through online e-Procurement system to the Tender Inviting Authority (TIA) well before the bid submission end date and time (as per Server System Clock).
21. Tender form Fee and EMD shall be submitted with the Part I- Technical BID. BID submitted without fees, as mentioned above will not be considered for evaluation and shall be rejected summarily. The benefit of Exemption of EMD and tender fee to all Micro and small enterprises (MSE) registered with district industries center (DIC) or Khadhi and village industries commission or Khadhi and Industries board (KVIV) or Coir board or National Small Industries Corporation (NSIC) or Directorate of handicrafts and handlooms or any other body specified by Ministry of MSME, will be considered. The bidder shall upload with their offer, the proof of their being MSE.
22. The bidder/tenderer/contractor shall file the applicable returns with Tax departments in time and submit the same as documentary proof. The GST applicable shall be shown as a separate line item in the Tax invoices to avail in put credit to Port.

2. Cover – I Details (Technical)

The following documents shall be uploaded online only.

1. Scanned copy of NEFT Payment details for cost of tender / documentary evidence for exemption of tender fee.
2. Scanned copy of RTGS/NEFT Payment details for EMD (bid security) / documentary evidence for exemption of EMD
3. Scanned copy of documents as per Annexure 1 to 13 of section I(iii) of volume-I (Original power of attorney i.e. Annexure 2 to be submitted by post or by hand immediately after the closing date for submission of online e-tender). However, such Power of Attorney would not be required if the Application is signed by an authorized partner or Director (on the Board of Directors) of the Applicant, in case the Applicant is a partnership firm or limited liability partnership.
4. Scanned copy of valid PAN card, ESI, PF and GST Registration certificate.
5. List of Ongoing works in hand at NMPA should be indicated in the prescribed form.
6. Scanned copy of Form of Tender as per Section VI(iii) of volume -III
7. Technical bid document – Cover I (Volume I to Volume III) along with amendments and clarifications.

3. Cover – II Detail (Finance)

PRICE BID (Bill of Quantities)

Price should be quoted in the BOQ template available in the portal. The BOQ template must not be modified/replaced by the bidder and the same should be uploaded after filling the relevant columns, else the bidder is liable to be rejected for that tender. Bidders are allowed to enter the Bidder Name and Values only.

Any indication of 'Quoted price' in the online technical bid documents shall lead to rejection of the bid outright.

The price bid submitted through e-portal mode only will be taken up for the purpose for evaluation.

4. Opening of bids

A. Part I Techno-Commercial bid will be opened electronically on specified date and time as given in the NIT. Bidder(s) can witness electronic opening of bid.

B. Part II Price bid will be opened electronically of only those bidder(s) whose Part I Techno-Commercial Bid is found to be Techno-Commercially acceptable by NMPA. Such bidder(s) will be intimated, the date of opening of Part II Price bid, through valid email confirmed by them

Note: The tenderers are advised to offer their best possible rates. There would generally be no negotiations hence most competitive prices may be quoted while submitting the price bid. However, in case the lowest rate appears to be reasonable taking into account the prevailing market conditions, the work may be awarded to the lowest bidder and if the rate is still considered high, action as per prevailing instructions / guidelines shall be taken. All entries in the tender should be entered in online Technical & Commercial Formats without any ambiguity.

5. Evaluation process:

A proposal shall be considered responsive if –

- a. It is received by the proposed Due Date and Time.
- b. It is properly signed.
- c. It contains the information and documents as required in the Tender Document.
- d. It contains information in formats specified in the Tender Document.
- e. It mentions the validity period as set out in the document.
- f. It provides the information in reasonable detail. The Port Authority reserves the right to determine whether the information has been provided in reasonable detail.
- g. There are no significant inconsistencies between the proposal and the supporting documents.
- h. The Technical qualification conforms to as specified in the qualification criteria.
- i. A Tender that is substantially responsive is one that conforms to the preceding requirements without material deviation or reservation. A material deviation or reservation is one (1) which affects in any substantial way, the scope, quality, or performance of the Tenderer or (2) which limits in any substantial way, inconsistent

with the Tender document, or (3) whose rectification would affect unfairly the competitive position of other Qualified Applicant presenting substantially responsive bids.

- j. The Port Authority reserves the right to reject any tender which in its opinion is non-responsive and no request for alteration, modification, substitution or withdrawal shall be entertained by the Port Authority in respect of such Tenders.
- k. The Port Authority would have the right to review the Technical Qualification and seek clarifications wherever necessary.
- l. Since the tender involves selection based on pre-qualification criteria and technical specification, the Chief Engineer will examine and seek clarification if any and list out the firms, which are found technically suitable and Cover-II Price Bid of such tenderers only will be opened and EMD will be returned to the unsuccessful tenderers
- m. The date and time will be intimated to tenderers whose offers are found suitable and Cover – II of such tenderers will be opened on the specified date and time
- n. The cost of stamping Agreement must be borne by the successful Tenderer
- o. The Fax/E-Mail offers will be treated as defective, invalid and rejected. Only detailed complete offers received through online prior to closing time and date of the tenders will be taken as valid.

B. Instructions To Tenderers (General)

1. Introduction:

This work essentially comprises of “Providing M30 grade concrete for Remaining Portion of Berth No. 2 inside wharf area”

2. Applicants:

Contractors who wish to bid for the tender for the contract work should apply for the tender document. The successful bidder will be expected to complete the works by the intended completion date specified in the Contract document.

3. Invitation for Bids:

The online Invitation for Bids is open to all eligible bidders meeting the eligibility criteria. The bidders may submit bids for the works detailed in the NIT through e-tender mode only.

4. Purchase of Tender Documents:

Tender document can be downloaded from NMPA website www.newmangaloreport.gov.in, www.tender.gov.in & <https://www.eprocure.gov.in/eprocure/app> of CPP portal

5. One Bid per Bidder:

Each bidder shall submit only one bid for one package. Bidder who submits or participates in more than one Bid will cause all the proposals with the Bidder's participation to be

disqualified.

6. Cost of Bidding:

The bidder shall bear all costs associated with the preparation and submission of his Bid, and the Employer will in no case be responsible and liable for those costs.

7. Site visit:

The Bidder, at the Bidder's own responsibility and risk is encouraged to visit and examine the work site and its surroundings and obtain all information that may be necessary for preparing the Bid and entering into a contract for construction of the Works. The costs of visiting the site shall be at the Bidders' own expense.

8. Content of Bidding Documents:

Tender Document will consist of:

Volume I	Section I	Notice Inviting Tenders Instructions to Tenderers Annexure (1 to 13)
	Section II	Form of Agreement
	Section III	Conditions of Contract: Part A - E: General Conditions Conditions of Contract : Part F: Special Conditions Contract Data Form of Securities (A & B) Appendix – I and Appendix - II
Volume II	Section IV	Technical Specifications
	Section V	Drawings
Volume III	Section VI	Preamble Bill of Quantities For of tender
	Section VII	Schedules (A & B)

Any indication of "Quoted price" in the technical bid, shall lead to rejection of the bid outright. For evaluation purpose the uploaded offer documents will be treated as authentic and final. No hard copy shall be submitted, upload the entire document on the CPP portal only.

9. Clarification of the Bidding Documents:

The Tenderers are advised to examine the Tender Document carefully and if there be or appear to be any ambiguity or discrepancy in the documents, or any clarifications needed on the Tender Documents; these shall be referred to the Chief Engineer (Civil) in writing, so as to reach at least three days before start date of submission of bid. It is to be noted that queries asked after due date will not be answered. Employer's clarifications shall be furnished in the CPP e-portal or shall be issued a corrigendum in the web site after closing

date of online pre-bid meeting without identifying the source.

10. Amendment of Bidding Documents:

Any modification of the tender documents as a result of any ambiguity shall be made exclusively through the issue of an Addendum. Any addendum thus issued shall be part of the tender documents and will be uploaded in CPP e-portal and Port website to all the bidders. Prospective bidders shall acknowledge receipt of each addendum to the Employer. Such addenda will be numbered and it shall be submitted by the Tenderers as part of Part I of their bid. The Addendum can also be downloaded from NMPA official website from 'Ongoing Project link'. The responsibility of downloading such addendum / amendment from NMPA website and CPP e-portal fully lies with the bidder

11. Preparation of bids:

All documents relating to the bid shall be in the English language.

12. Minimum Eligibility Criteria:

- a) The tenderers must have experience of having successfully or substantially completed *similar works during last 7 (seven) years ending last day of month previous to the one in which applications are invited shall be either of the following
At least Three similar completed works costing not less than the amount **Rs.33.25 lakhs each(Excluding GST)**

or

At least Two similar completed works costing not less than the amount equal to **Rs.41.56 lakhs each (Excluding GST)**

or

At least One similar completed works costing not less than the amount equal to **Rs.66.50 lakhs (Excluding GST)**

The tenderers must have executed key element of work i.e "Cement concrete pavement or Reinforced cement concrete pavement with **M30 or M40 grade of concrete**" not less than **250 Cum** in total among the work / works considered for eligible assignment.

Note 1: *Similar work(s) means "**Construction / Improvement of road or open yard or platform with cement concrete pavement or Reinforced cement concrete pavement of M30 or M40 grade including allied works**"

Note 2: Documentary evidence for successful / substantial completion of the work shall be furnished along with work order and work completion certificate.

Note 3: Substantial completion shall be based on 80 (eighty) per cent (value wise) or more works completed under the contract. Certificate for 'substantial completion' of project/work/asset should contain two parts. Part -I shall contain 'financial value of work done' and part-II shall contain 'certificate of functional completion of project/work/asset'.

Note 4: The value of executed works shall be brought to current costing level by

enhancing the actual value of the work upon completion by using the following enhancement factors. For intermediate periods, the actual number of years will be calculated based on number of days and the enhancement / multiplying factor will be interpolated accordingly and the same will be considered for evaluation.

Year before	Enhancement / Multiplying factor
One year	1.07
Two years	1.14
Three years	1.21
Four years	1.28
Five years	1.35
Six years	1.42

- b) Average Financial turnover of the tenderer over the last three financial years 2021-22, 2022-23 and 2023-24 shall be at least Rs.24.95 lakhs.

The financial capacity of bidders would be evaluated considering the works in hand at NMPA on the due date of submission of bid. The port would deduct the turnover required for execution of work in hand at NMPA from the average financial turnover of the bidder. The remaining net financial turnover of the bidder will be considered for eligibility criteria.

The financial capacity to be 3.33times of the average financial turnover of last three years of the bidder minus works in hand at NMPA. The bidder must fill the Annexure-6.

In case the average turnover is Rs. 3.00crores, the financial capacity of the contractor will considered as (3x3.333) Rs.10.00crores.

The turnover means sales / contract receipts excluding taxes other income shall not be considered for calculation of turnover.

- c) The tenderer shall submit a copy of valid ESIC & EPF registration certificate along with the tender.

Copy of the work order, Client's satisfactory work completion Certificate, along with any other documentary proof certifying the date of completion, brief description of the project and project completion cost shall be submitted in support of the assignments performed and claimed by the tenderer to fulfill the eligibility criteria for qualification. Experience of the tenderer / contractor for completed works, executed in private organization shall be considered only if the Tax Deducted at Source Certificate with respect to referred work, issued by Competent Authority is enclosed by the tenderer along with the tender. In case work executed on subcontract, only approved or authorized subcontract shall be considered for eligible assignment.

A statement duly certified by the Chartered Accountant showing the average annual Financial Turnover over the last 3 financial years duly indicating UDIN shall be submitted.

Even though the bidders meet the above qualifying criteria, they are subject to be disqualified if they have:

- i) made misleading or false representations in the forms, statements and attachments submitted in proof of the qualification requirements; and/or
- ii) record of poor performance such as abandoning the works, not properly completing the contract, inordinate delays in completion, litigation history, or financial failures etc.,

13. Bid Prices:

The contract shall be for the whole works as described in based on the priced Bill of Quantities submitted through CPP e-portal by the Bidder. The Bidder shall fill in the percentage of Excess or Less in the Bill of Quantities through CPP e-portal. Items for which no rate or price is entered will not be paid for by the Employer when executed and shall be deemed covered by the other rates and prices in the Bill of Quantities.

14. Currencies of Bid and Payment:

The Unit rates and the prices shall be quoted by the bidder entirely in Indian Rupees

15. Bid Validity:

Bids shall remain valid for a period not less than ninety days (90 days) after the last date for online bid submission. A bid valid for a shorter period shall be rejected by the Employer as non-responsive.

In exceptional circumstances, prior to expiry of the original bid validity period, the Employer may request that the bidders may extend the period of validity for a specified additional period. The request and the bidders' responses shall be made in writing or by cable. A bidder agreeing to the request will not be permitted to modify his bid and also shall submit an extension for EMD, if it is in the form of Bank Guarantee

16. Bid Security / EMD:

- i. The EMD shall be in the form of Insurance Surety Bonds, Account Payee Demand draft, Fixed Deposit Receipt, Bankers Cheque or shall be paid by RTGS/NEFT in favour of Financial Adviser & Chief Accounts Officer, New Mangalore Port Authority, Mangalore
 1. Name of the Bank: State Bank of India, Panambur, Mangalore - 10.
 2. Bank A/C No. 10205649448
 3. IFSC Code: SBIN0002249
 4. MICR Code: 575002011
- ii. The Techno Commercial Bid shall be accompanied by the RTGS/NEFT deposit details towards Earnest Money Deposit of Rs. 196300/- (Rupees One Lakh NinetySix Thousand Three Hundred Only) as stipulated in the tender. The tender without EMD shall be treated invalid. The benefit of Exemption of EMD and tender fee to all Micro and small enterprises (MSE) registered with district industries center (DIC) or Khadhi and village industries commission or Khadhi and Industries board (KVIV) or Coir board or National Small Industries Corporation (NSIC) or Directorate of handicrafts and handlooms or any other body specified by Ministry of MSME, will be considered. The bidder shall upload with their offer, the proof of their being MSE.
- iii. In the event of Bidder withdrawing his Bid before the expiry of tender validity period of 90 days from the last date for online bid submission, the tender shall be cancelled and EMD shall be forfeited.
- iv. The Earnest Money Deposit of unsuccessful bidder shall be returned without interest as early as possible by RTGS/NEFT on conclusion of contract. The Earnest Money Deposit of the successful bidder shall be refunded (without interest) after he has signed the agreement and furnished required performance security.
- v. The Bid Security of a successful bidder will be forfeited in the following cases:
 - a) If the bidder withdraws his tender during the period of bid validity.
 - b) In case of a successful tenderer fails
 - i) to commence the work, apart forfeiture of other claims
 - ii) within the specified time limit to sign the Agreement or furnish the required

Performance Security. In the event of forfeiting the EMD / SD / LD and while imposing penalty GST as applicable will be collected.

17. No Alternative Proposals by Bidders:

Bidders shall submit offers that comply with the requirements of the bidding documents, including the basic technical design as indicated in the drawing and specifications. Alternatives will not be considered.

18. Format and Signing of Bid:

The Bid shall be in online mode. The Bid shall contain no alterations or additions, except those comply with instructions issued by the Employer

19. Bid Submission:

Tender document including quoted bid price have to be submitted online only through CPP Portal before deadline for online submission of bid.

For evaluation purpose the uploaded offer documents will be treated as authentic and final. Any documents submitted in the form of hard copy except Power of attorney.

The Tender shall be submitted in Two Bids.

I. Technical Bid: Shall contain the following.

- i) Techno Commercial Bid: Shall contain all the documents. Techno Commercial Bid should not contain Price Bid. "Disclosure/indication of Price in the Techno Commercial Bid shall render the tender disqualified and rejected.
- ii) The details of payment of EARNEST MONEY DEPOSIT for Rs. 196300/- (Rupees One Lakh NinetySix Thousand Three Hundred Only) by RTGS/NEFT to NMPA Bank Account, failing which the Techno commercial Bid shall not be considered).
- iii) Transaction details of payment towards the COST OF TENDER Fee: Rs. 1120/- (Rupees One Thousand One Hundred Twenty Only) (To be paid by RTGS/NEFT to NMPA Bank Account).

II. FINANCIAL BID: shall contain only the Price.

III. LAST DATE FOR SUBMISSION OF ONLINE TENDER: is as per the date mentioned in the NIT

NMPA may at its sole discretion reserves the right to extend the date for receipt of Bid. Bid after the aforesaid time and date or the extended time and date, if any, shall not be accepted by the portal.

The following details pertaining to Techno Commercial Bid shall be uploaded online.

- a) Letter of Submission- Covering letter (vide Annexure – 1)
- b) Power of Attorney in favour of signatory/s to the Tender,(vide Annexure -2) (Original power of attorney ie. Annexure 2 to be submitted by post or by hand so as to reach the Executive Engineer (Civil) immediately after the closing date for submission of online e-tender). However, such Power of Attorney would not be required if the Application is signed by an authorized partner or Director (on the Board of Directors) of the Applicant, in case the Applicant is a partnership firm or limited liability partnership.

- c) Organization Details (vide Annexure-3)
- d) Details of "Minimum eligibility criteria" as per Clause 12 of instruction to Tenderers and certificates (Client Certificates / work completion certificates or any other documentary evidences with respect to the eligibility work) (vide Annexure-4) of condition of contract. The following specific instruction may be noted ;
 - i) Bidders are expected to provide information in respect of Eligible Assignments in this Section. The assignments cited must comply with the criteria specified in Clause No. 12 (a) for "Minimum eligibility".
 - ii) A separate sheet should be filled for each of the eligible assignments the details are to be supplemented by documentary proof from the respective client for having carried out such assignment duly certified by client's completion certificates and work orders etc.
 - iii) The works indicated in Annexure- 4 will only be considered for evaluation. Mere submission of work completion certificate will not be considered as Eligible Assignments
- e) A statement duly certified by Chartered Accountant showing Average Financial turnover of the tenderer over the last three financial years duly indicating UDIN (vide Annexure-5) with balance sheet.
- f) List of Ongoing works in hand at NMPA should be indicated in the prescribed form (Annexure 6)
- g) A list of Plant and equipment proposed to be engaged for work(vide Annexure-7) The equipment indicated in the Annexure -7 will form part of contract agreement and as such the bidders are requested to indicate the availability of the equipment at site at what stage of the construction period the equipment would made available.
- h) Tenderer should submit copy of Permanent Account Number(PAN), ESI, PF and GST Registration (GSTIN) Number along with certificates issued by the authority as applicable
- i) A declaration to the effect that (vide Annexure -8):-
 - a. All details regarding construction plant and machinery, temporary work and personnel for site organization considered necessary and sufficient for the work have been furnished in the Annexure to Conditions of Contract in Volume I and that such plant, temporary works and personnel for site organization will be available at appropriate time of relevant works for which the equipment have been proposed at site till the completion of the respective work.
 - b. No conditions are incorporated in the financial bid. In case any conditions are specified in the financial bid, the tender will be rejected summarily without making any further reference to the bidder.
 - c. We have not made any payment or illegal gratification to any persons/ authority connected with the bid process so as to influence the bid process and have not committed any offence under PC Act in connection with the bid.

- d. We disclose with that we have made / not made payments or propose to be made to any intermediaries (agents) etc in connection with the bid.
- j) NEFT Payment details towards cost of tender / documentary evidence for exemption of tender cost.
- k) RTGS/NEFT Payment details towards EMD / documentary evidence for exemption of EMD

20. Deadline for Submission of the Bids:

- i) The completed bid shall be submitted in the electronic form by the date and time mentioned in NIT only through CPP e-portal.
- ii) The Employer may extend the deadline for submission of bids by issuing an amendment in accordance with Clause 10, in which case all rights and obligations of the Employer and the bidders previously subject to the original deadline will thereafter be subject to the deadline as extended.
- iii) Price should be quoted in CPP e-portal. Any indication of 'Quoted price' in the online technical bid documents shall lead to rejection of the bid outright. For evaluation purpose the uploaded offer documents will be treated as authentic and final. No hard copy shall be submitted for reference purpose. The bid submitted through e-tendering mode only will be taken up for the purpose for evaluation.
- iv) The uploaded Port Tender Document will be treated as authentic tender and if any discrepancy is noticed at any stage between the Port's tender document and the one submitted/uploaded by the tenderer, the conditions mentioned in the Port's uploaded document shall prevail. Besides, the tenderer shall be liable for legal action for the lapses.

21. Late Bids:

The time that is displayed from the server clock at the top of the CPP e-portal, will be valid for all actions of requesting bid submission, bid opening etc., The bidders should adhere to this time during bid submission.

22. Modification and Withdrawal of Bids:

- i) Bidders may modify the offers by deleting their already freezed bids in online only through CPP e-portal (after submission of bid) and resubmit/upload the revised offer before the deadline prescribed in Clause 20.
- ii) No bid shall be withdrawn and resubmitted through CPP e-portal by the bidder after the deadline for submission of bids.
- iii) Withdrawal of a Bid between the deadline for submission of bids and the expiration of the original period of bid validity specified in Clause 15 may result in the forfeiture of the Bid Security or the bidder shall be disqualified from bidding for any contract with New Mangalore Port Authority for a period of 2 (two) years in pursuant to

Clause 16.

- iv) Bidders may only modify the prices and other required details of their Bids by Resubmitting Bid only in accordance with this clause through CPP e-portal.

23. Bid Opening - Technical Bid:

- a. On the due date and time as specified in Clause 20, the Employer will first open Techno Commercial bids of all bids received online in presence of the Bidders or their representatives who choose to attend. In the event of specified date for bid opening is declared as holiday by the Employer, the bid will be opened at the appointed time and location on the next working day.
- b. In the first instance the Techno Commercial Bid containing the RTGS/NEFT payment details of EMD & Cost of tender document will be verified. If EMD and Tender Fee is in line with the Tender Condition there after the Techno Commercial Bid will be considered for evaluation.
- c. If all Bidders have submitted unconditional Bids together with requisite Bid security, then all Bidders will be so informed then and there. If any Bid contains any deviation from the Bids documents and / or if the same does not contains Bid security in the manner prescribed in the Bid documents, then that Bid will be rejected and the Bidder informed accordingly.

24. Bid Opening – Financial Bid:

The date and time of opening of price bid (cover-II) shall be intimated to the qualified bidders based on the evaluation of the technical bid. The price bid (cover-II) of such eligible bidders shall be opened on the specified date and time.

If bidder withdraws his tender after opening of price bid the bidder will be disqualified for participating in NMPA tender for a period of two years.

25. Clarification of Bids:

To assist in the examination and comparison of Bids, the Employer may, at his discretion, ask any Bidder for clarification of his Bid, including breakdown of unit rates. The request for clarification and the response shall be in writing, but no change in the price or substance of the Bid shall be sought, offered, or permitted.

No Bidder shall contact the Employer on any matter relating to his bid from the time of the bid opening to the time the contract is awarded. If the Bidder wishes to bring additional information to the notice of the Employer, he should do so in writing.

Any effort by the Bidder to influence the Employer's bid evaluation, bid comparison or contract award decisions, may result in the rejection of his bid.

Employer reserves the right to reject any Bid, if the Bidder does not provide the clarification sought for by the Employer, within the time specified by the Employer, for proper evaluation of the Bid

26. Examination of Bids and Determination of Responsiveness:

Prior to detailed evaluation of Bids, NMPA will determine whether each Bid

- a) meets the eligibility criteria as defined in Clause 12.
- b) has been properly signed by an authorized signatory (accredited representative) holding Power of Attorney in his favour. The Power of Attorney shall inter alia include a provision to bind the Bidder to settlement of disputes clause; However, such Power of Attorney would not be required if the Application is signed by an authorized partner or Director (on the Board of Directors) of the Applicant, in case the Applicant is a partnership firm or limited liability partnership.
- c) is accompanied by the requisite Bid security and;
- d) is responsive to the requirements of the Bidding documents.

A responsive Bid is one which conforms to all the terms, conditions and specification of the Bidding documents, without material deviation or reservation. A material deviation or reservation is one

- a) which affects in any substantial way the scope, quality or performance of the Works;
- b) which limits in any substantial way, the Employer's rights or the Bidder's obligations under the Contract; or
- c) whose rectification would affect unfairly the competitive position of other Bidders presenting responsive Bids.

The tenderer shall submit a certificate in the tender schedule in the Technical Bid that he has not incorporated any conditions in the Financial Bid and in case any conditions are specified in the financial bid his tender will be rejected without making any further reference to him.

If a Bid is not substantially responsive, it shall be rejected by the Employer, and may not subsequently be made responsive by correction or withdrawal of the non-conforming deviation or reservation.

27. Correction of Errors: (Not Applicable)

28. Evaluation and Comparison of Bids:

The Employer will evaluate and compare only the Bids determined to be responsive in accordance with Clause 26. In evaluating the Bids, the Employer will determine for each Bid the evaluated Bid Price by adjusting the Bid Price as follows:

- a) making appropriate adjustments to reflect discounts or other price modifications offered in accordance with Clause 22.

29. Alteration of tender documents:

No alteration shall be made in any of the tender documents or in the Bill of Quantities and the tender shall comply strictly with the terms and conditions of the tender document. The

Employer may however ask any tenderer for clarifications of his tender if required. Nevertheless, no tenderer will be permitted to alter his tender price after opening of the tender.

30. Alternative conditions and Proposal:

The Tenderer shall note that alternative or qualifying tender conditions, or alternative design proposal for whole or part of the work will not be acceptable. Tenders containing any qualifying conditions or even Bidder's clarifications in any form will be treated as non-responsive and will run the risk of rejection. Part II: Price Bid of such Bidder's will not be opened.

31. Award of Contract:

The Employer will award the Contract to the bidder whose bid has been determined to be responsive to the bidding documents and who has offered the lowest evaluated bid price, provided that such bidder has been determined to be

- a) Eligible in accordance with the provisions of Clause 12, and
- b) Qualified in accordance with the provisions of Clause 12.

32. Notification of Award:

- i) The Bidder whose Bid has been accepted will be notified about the award by the Employer prior to expiration of the Bid validity period by, fax or e-mail and confirmed by registered letter. This letter (hereinafter and in the Conditions of Contract called the "Letter of Acceptance") will state the sum that the Employer will pay the Contractor in consideration of the execution, completion and maintenance of the works by the Contractor as prescribed by the Contract (hereinafter and in the Contract called the "Contract Price").
- ii) The notification of award will constitute the formation of the Contract subject only to the furnishing of a performance security in accordance with the provisions of Clause 33.

The Agreement will also incorporate all correspondence exchanged between the employer and the successful bidder. Within 21 days of receipt of Letter of Acceptance, the successful bidder will furnish the performance security and sign the Agreement with the Employer. The contractor shall make 12 copies of the Agreement and submit to the employer within 7 days following the date of signing of Agreement. No work shall be commenced without signing contract agreement.

33. Release of Bid Security/EMD:

The Earnest Money Deposit of unsuccessful bidder, shall be returned without interest by RTGS/NEFT on conclusion of Contract. The Earnest Money Deposit of the successful bidder if deposited in cash, shall be refunded (without interest) after he has signed the agreement and furnished required performance security.

34. Performance Security:

- i) Within 21 days of receipt of the Letter of Acceptance, the successful Bidder shall deliver to the Employer a Performance Security in the form in the form of Insurance Surety Bonds, Account Payee Demand draft, Fixed Deposit Receipt from a commercial bank, remittance by RTGS or in the form of Bank Guarantee for an amount equivalent to 5% of the Contract price including GST, as applicable rounded off to the nearest 1000.
- ii) If the performance security is provided by the successful Bidder in the form of a Bank Guarantee, it shall be issued by a Nationalized /Scheduled Indian bank having its branch at Mangalore acceptable by NMPA. The BG shall be issued in favor of New Mangalore Port Authority in the Format enclosed in Volume I as Annexure-A.

35. Fraud and Corrupt Practices:

The bidder and their respective officers, employees, agents and advisers shall observe the highest standard of ethics during the Selection Process. Notwithstanding anything to the contrary contained in this document, the Port shall reject the tender without being liable in any manner whatsoever to the bidder, if it determines that the bidder has, directly or indirectly or through an agent, engaged in corrupt practice, fraudulent practice, coercive practice, undesirable practice or restrictive practice (collectively the "Prohibited Practices") in the Selection Process. In such an event, the Port shall, without prejudice to its any other rights or remedies, forfeit and appropriate the Bid Security or Performance Security, as the case may be, as mutually agreed genuine pre-estimated compensation and damages payable to the Port for, inter alia, time, cost and effort of the Authority, in regard to the Tender, including consideration and evaluation of such Bidder's Proposal. Such Bidder shall not be eligible to participate in any tender or RFP issued by the Authority during a period of 2 (two) years from the date such Bidder is found by the Authority to have directly or through an agent, engaged or indulged in any corrupt practice, fraudulent practice, coercive practice, undesirable practice or restrictive practice, as the case may be.

For the purposes of this Clause, the following terms shall have the meaning hereinafter respectively assigned to them:

(a) "corrupt practice" means

- i) the offering, giving, receiving, or soliciting, directly or indirectly, of anything of value to influence the action of any person connected with the Selection Process (for avoidance of doubt, offering of employment to or employing or engaging in any manner whatsoever, directly or indirectly, any official of the Authority who is or has been associated in any manner, directly or indirectly with the Selection Process or the LOA or has dealt with matters concerning the Agreement or arising there from, before or after the execution thereof, at any time prior to the expiry of one year from the date such official resigns or retires from or otherwise ceases to be in the service of the Authority, shall be deemed to constitute influencing the

- actions of a person connected with the Selection Process; or
- ii) engaging in any manner whatsoever, whether during the Selection Process or after the issue of the LOA or after the execution of the Agreement, as the case may be, any person in respect of any matter relating to the Project or the LOA or the Agreement, who at any time has been or is a legal, financial or technical consultant/ adviser of the Authority in relation to any matter concerning the Project;
- (b) "fraudulent practice" means a misrepresentation or omission of facts or disclosure of incomplete facts, in order to influence the Selection Process;
- (c) "coercive practice" means impairing or harming or threatening to impair or harm, directly or indirectly, any persons or property to influence any person's participation or action in the Selection Process;
- (d) "undesirable practice" means
- i) establishing contact with any person connected with or employed or engaged by the Authority with the objective of canvassing, lobbying or in any manner influencing or attempting to influence the Selection Process; or
- ii) having a Conflict of Interest; and
- (e) "Restrictive practice" means forming a cartel or arriving at any understanding or arrangement among Applicants with the objective of restricting or manipulating a full and fair competition in the Selection Process.

36. Rejection of Tender:

Any Tender not conforming to the foregoing instructions will not be considered. The Employer does not bind himself to accept the lowest or any tender and has the right to reject any tender without assigning any reason thereof. No representation whatsoever will be entertained on this account.

37. Additional Information:

The "Instructions to Tenderers" shall not form part of the Contract. They are intended only to aid the Tenderers in the preparation of their tender.

38. Compliance of Local Content as per Make in India Policy:

Bidder shall comply with DPIIT Order No. P-45021/2/2017-PP(B-II) dtd. 16-09-2020 in respect of Local Content and furnish an undertaking in the prescribed format as per Annexure 14, to that effect, failing which, the bid may be liable for cancellation.

Annexure – 1**LETTER OF SUBMISSION - COVERING LETTER
(ON THE LETTER HEAD OF THE BIDDER)**

Date:

To

The Executive Engineer (Civil),
New Mangalore Port Authority,
Administration Building,
Panambur, Mangalore – 575 010

Sir,

Sub: The work of “Providing M30 grade concrete for Remaining Portion of Berth No. 2 inside wharf area”

Being duly authorized to represent and act on behalf of
(Hereinafter referred to as “the Bidder”) and having reviewed and fully understood all of the requirements of the bid document and information provided, the undersigned hereby apply for the project referred above.

We are submitting our Bid enclosing the following, with the details as per the requirements of the Bid Document, for your evaluation.

- i. Tender Document along with Addendum No ----,
- ii. Power of Attorney - (Annexure - 2)
- iii. Organization Details - (Annexure - 3)
- iv. Details to fulfill the “Minimum Eligibility Criteria” and certificates - (Annexure 4)
- v. Average Financial turnover over the last three financial year - (Annexure 5)
- vi. List of ongoing works at New Mangalore Port (Annexure - 6)
- vii. List of plant and equipment – (Annexure - 7)
- viii. Declaration – (Annexure – 8)
- ix. Bid Security / EMD Paid by RTGS/NEFT vide UTR No.....dtd. of
(name and address of the branch).
- x. Banker’s Details – Annexure 10 & 11
- xi. Tender fee paid by NEFT vide UTR No.....dtd. of (name and
address of the branch).
- xii. Copy of valid PAN Card ESI, PF & GST Registration certificate.
- xiii. Bid security (Annexure -13)

Signature
(Authorised Signatory)

Annexure – 2

ON STAMP PAPER of Rs 500/-
 “PROVIDING M30 GRADE CONCRETE FOR REMAINING PORTION OF BERTH
 NO. 2 INSIDE WHARF AREA”

--

FORMAT OF POWER OF ATTORNEY (in original)

In favour of signatory/s to the Tender, duly authenticated by Notary Public.

POWER OF ATTORNEY IN FAVOUR OF ----- (Name,
 Designation, Company name)

TO ALL TO WHOM THESE PRESENTS shall come, I, (Name & address of the authorized person to sub-delegate/delegate powers, delegated on him by the Board of Directors) do hereby sub-delegate/delegate, in terms of the powers delegated to me by the Board of Directors, ----- (name of the Co.) to Shri ----- (name, designation & address of the Attorney) the following:

NOW KNOW YE AND THOSE PRESENTS that I, (Name & address of the authorized person to sub-delegate/delegate powers, delegated on him by the Board of Directors), do hereby authorize and empower Shri ----- (name, designation & address of the Attorney) to do severally amongst others, for the purpose of carrying on our business, the following:

- a) To represent lawfully the (name of the Co.) for obtaining bid/tender documents, prepare, sign, execute and submit tenders for execution of (Providing M30 grade concrete for Remaining Portion of Berth No. 2 inside wharf area)or any other works incidental to such construction works.
- b) To discuss the technical and financial matters, negotiate and accept prices and take decisions regarding terms and conditions and sign agreements and contracts and also to bind the (name of the Co.) to the arbitration clause included in the contract.
- c) For all or any of the purposes here of to sign and deliver or otherwise execute such deed or deeds, transfer or transfers, endorsement or endorsements and to perform such other acts, matters, things as the Attorney shall consider requisite or advisable as full and effectively as the Company could do, if present and acting there.

I, (Name & address of the authorized person to sub-delegate/delegate powers, delegated on him by the Board of Directors) in terms of the powers delegated to me by the Board of Directors of (name of the Co.), do hereby agree that all acts, deeds and things done by the said Attorney by virtue of this power of attorney, shall be construed as acts, deeds and things done by the Company.

I, (Name & address of the authorized person to sub-delegate/delegate powers, delegated on him by the Board of Directors), further undertake to ratify and confirm whatever our said attorney shall do or cause to be done for the Company, the said Company, in the premises, by virtue of the powers hereby given.

WHEREAS, this sub-delegation is signed and delivered to Shri ----- (name &

designation of the Attorney), on this _____ day of _____, 20____ (Two thousand _____).

WHEREAS, even though this sub-delegation is signed on this _____ day of _____ 20____ (Two thousand _____), will have effect from the date he signs and receives this delegation.

IN WITNESS WHEREOF, I, (Name & address of the authorized person to sub-delegate/delegate powers, delegated on him by the Board of Directors) has, this _____ day of _____ 20____ (Two thousand _____) set my hands and subscribed my signature unto this instrument.

SIGNED AND DELIVERED ON _____ BY

(Name of authorized person to delegate powers)

WITNESS:

SIGNED AND RECEIVED ON _____ BY (Name & designation of Attorney)

Note: i) This Document to be duly authenticated by Notary Public. ii) Please strike off whichever is not applicable.

Annexure – 3

“PROVIDING M30 GRADE CONCRETE FOR REMAINING PORTION OF BERTH
NO. 2 INSIDE WHARF AREA”

--

ORGANIZATION DETAILS

CONTACT No.:

NAME OF APPLICANT:

1. Name of the Owner:
2. Address:
 - Telephone No. :
 - Fax No.
3. Description of Applicant
(for e.g. General, Civil Engineering etc.)
4. Registration and Classification of Contractors:
5. Name and address of bankers:
6. Number of years of experience as a general contractor:-
 - In own Country:
 - Internationally:
7. Number of years of experience as a sub-contractor:
Name and Address of partners or associated companies to be involved in the project and whether Parent/Subsidiary/other:
8. Name and address of any associates knowledgeable in the procedures of customs, immigration and local experience in various aspect of the project etc.
9. Name and address of the companies / Sub-contractors who will be involved in the execution of works, namely:

Signature
(Authorised Signatory)

NEW MANGALORE PORT AUTHORITY**“PROVIDING M30 GRADE CONCRETE FOR REMAINING PORTION OF BERTH NO. 2 INSIDE WHARF AREA”**

Tenderer shall furnish Details of “eligibility works experience” as per Clause 12(a) of Minimum Eligible Criteria (MEC) of Instruction to Tenderer and certificates in the following format (Client Certificates/work completion certificates or any other documentary evidences with respect to the eligibility work)

ELIGIBLE ASSIGNMENT DETAILS FOR MEC

Assignment Number:

Sl. No	Description	Bidder to fill up the details here
1	Name and Address of the Client	
2	Title of the Eligible Assignment	
3	Date of completion of the Eligible Assignment	
4	Project Cost	
5	Reference No of the enclosed work order	
6	Reference No of the enclosed Client work Completion Certificate	
7	Reference No of any other documentary evidence; if enclosed.	
8	Name, telephone no, telefax no and email address of the client's representative	
9	Description and Scope of Work	

Signature

(Authorised Signatory)

Certificate from the Statutory Auditor

This is to certify that the information contained in Sl. No 4 above is correct as per the accounts of the Applicant and/ or the clients.

(Signature, name and designation of the authorised signatory duly indicating UDIN)

Date: Name and seal of the audit firm:

In case the Applicant does not have a statutory auditor, it shall provide the certificate from its chartered accountant that ordinarily audits the annual accounts of the Applicant duly indication UDIN.

Instructions:

- i. Bidders are expected to provide information in respect of Eligible Assignments in this Section. The assignments cited must comply with the criteria specified Clause No. 12.0(a) Minimum eligibility of the “Instructions to Tenderers”.
- ii. A separate sheet should be filled for each of the eligible assignments.
- iii. The details are to be supplemented by documentary proof (Work order and work completion certificate) from the respective client for having carried out such assignment duly certified by clients.

Annexure – 5

**NEW MANGALORE PORT AUTHORITY
 “PROVIDING M30 GRADE CONCRETE FOR REMAINING PORTION OF BERTH
 NO. 2 INSIDE WHARF AREA”
 FINANCIAL CAPABILITY**

(A) Net worth & Average Annual Turnover of the Bidder

Net Worth	Turnover			
Year 1	Year 1	Year 2	Year 3	Average

Instructions:

Net Worth = (Subscribed and Paid-up Equity + Reserves) - (Revaluation reserves + Miscellaneous expenditure not written off + depreciation not provided for). Year 1 will be the Financial Year 2023-24. Year 2 shall be the year immediately preceding Year 1 and Year 3 shall be the year immediately preceding Year 2. The Bidder shall provide audited Annual Reports as required under this Bid Document.

Net worth & Annual turnover of the bidder shall be submitted duly verified by Chartered Accountant or Competent Authority duly indicating UDIN.

(B) (Here specify proposed sources of credit line to meet the Cash flow demand for the work)

Source of Credit line	Amount

There should be a letter from the Bank mentioning that line of credit offered is specifically for this work/contract.

NOTE: If the Tenderer intends to meet the “Cash Flow Demand” for the project through their internal resources without availing the loan of credit, a specific mention to be made to this effect and proof for such resources shall be enclosed.

Certified by C.A
(Authorised Signatory)

Signature

Annexure – 6

NEW MANGALORE PORT AUTHORITY
 “PROVIDING M30 GRADE CONCRETE FOR REMAINING PORTION OF BERTH
 NO. 2 INSIDE WHARF AREA”

LIST OF ONGOING WORKS IN HAND AT NEW MANGALORE PORT

The Tenderer shall furnish in the format given below details of works being carried out by him at the time of bidding in New Mangalore Port

Sl. No.	Name of work	Work order No. and Date	Value of Work Order in Rs.	Average annual financial turnover as per MEC for the work

Contractor

NEW MANGALORE PORT AUTHORITY
“PROVIDING M30 GRADE CONCRETE FOR REMAINING PORTION OF BERTH
NO. 2 INSIDE WHARF AREA”

DETAILS OF PROPOSED APPROACH & METHODOLOGY

Bidder shall furnish a detailed method statement (Technical Note) for carrying out of the works, along with a construction programme showing sequence of operation and the time frame for various segments of temporary and permanent works.

Signature
(Authorised Signatory)

Annexure – 7

NEW MANGALORE PORT AUTHORITY
 “PROVIDING M30 GRADE CONCRETE FOR REMAINING PORTION OF BERTH
 NO. 2 INSIDE WHARF AREA”

--

PLANT AND EQUIPMENT PROPOSED FOR THE WORK

Please indicate the main plant and equipment considered to be necessary for undertaking the work and whether this plant is ready in ownership or will be purchased or hired.

Description of equipment	Requirement no. / capacity	Owned / leased / to be procured	Nos / capacity	Age / condition	Remarks (from whom to be purchased)	At what stage of contract period the equipment will be available

Note: The equipment indicated in the above statement will form part of contract agreement and as such the bidders are requested to indicate the availability of the equipment at site and at what stage of the construction period in a separate column.

Signature
(Authorised Signatory)

NEW MANGALORE PORT AUTHORITY
“PROVIDING M30 GRADE CONCRETE FOR REMAINING PORTION OF BERTH
NO. 2 INSIDE WHARF AREA”

DECLARATION

We M/s. (Name & address of the bidder) hereby declare that:-

- i. I have read the tender document Vol. I (Section I to III) Vol.II (Section IV and V) and Vol.III (Section V and VII) and agreed to the terms and conditions mentioned therein.
- ii. All details regarding construction plant, temporary work and personnel for site organisation considered necessary and sufficient for the work have been furnished in the Annexures to Conditions of Contract in Volume I and that such plant, temporary works and personnel for site organisation will be available at the site till the completion of the respective work.
- iii. No conditions are incorporated in the financial bid. In case any conditions are specified in the financial bid, the tender will be rejected summarily without making any further reference to the bidder.
- iv. We have not made any payment or illegal gratification to any persons/ authority connected with the bid process so as to influence the bid process and have not committed any offence under PC Act in connection with the bid.
- v. We shall undertake that, the Employer i.e. NMPA is indemnified against all damages or compensation payable at Law in respect of or in consequence of any accident or injury to any workman or other person in the employment of the Contractor or Sub-Contractor against all claims, demands, proceedings, costs, charges and expenses whatsoever in respect thereof or in relation thereto and the Employer shall be at liberty to deduct or adjust from the Contractor's bills an amount that Employer may be called upon to pay towards claims, demands, proceedings, costs, charges and expenses Whatsoever in respect of or in relation to any accident or injury referred to above without any reference to the Contractor. The contractor shall execute indemnity bond in the prescribed format as per **Annexure - 12**
- vi. We shall comply with all the Central State and Municipal Laws and Rules and we shall be solely responsible for complying with the provisions of the Contract Labour (Regulations & Abolition) Act, 1970 & the contract labour (Regulation & Abolition) Karnataka Rules 1974 and rules there under and the enactments that may be applicable including ESI Act, the payment of wages act, Provident Fund Act, the Minimum Wages Act, the Factory's Act. The Workmen Compensation Act or any other applicable legislation and the Municipal by-laws or other statutory Rules and Regulations whatsoever in force if these are applicable. Any obligations finding or otherwise missed under any statutory enactments, rules & regulations there under shall be the

responsibility of the Contractor and the NMPA will take no responsibility for the same. The Contractor should take Workmen's Compensation Policy for his Workers, who are not covered under ESI and submit the same to the EIC immediately after commencement of the work

- vii. We undertake that, we are liable to pay all Statutory Compensation to the Labourers/persons engaged by him for the satisfactory execution of the works. If any claim is made against New Mangalore Port Authority on this work, the Port Authority shall have the right to deduct the same from the bill amount payable to the contractor after verification of the validity and if admissible as per rules
- viii. *We disclose with that we have made / not made payments or propose to be made to any intermediaries (agents) etc. in connection with the bid.

* Note: Delete whichever is not applicable.

Signature
(Authorised Signatory)

Annexure-9**BID SECURITY (BANK GUARANTEE) (NOT APPLICABLE)**

WHEREAS, _____ [Name of Bidder] (hereinafter called "the Bidder") has submitted his bid dated _____ [date] for the Providing M30 grade concrete for Remaining Portion of Berth No. 2 inside wharf area (hereinafter called "the Bid"). KNOW ALL PEOPLE by these presents that We _____ [name of bank] of _____ (name of country) having our registered office at _____ (hereinafter called "the Bank") are bound unto _____ [name of Employer] (hereinafter called "the Employer") in the sum of _____ 1 for which payment well and truly to be made to the said Employer the Bank binds itself, his successors and assigns by these presents.

SEALED with the Common Seal of the said Bank this _____ day of _____ 20 _____

THE CONDITIONS of these obligations are:

- (1) If after Bid opening the Bidder withdraws his Bid during the period of bid validity specified in the Form of Bid;
or
- (2) If the Bidder having been notified of the acceptance of his Bid by the Employer during the period of bid validity:
 - (a) fails or refuses to execute the Form of Agreement in accordance with the Instructions to Bidders, if required; or
 - (b) fails or refuses to furnish the Performance Security, in accordance with the Instructions to Bidders, or
 - (c) does not accept the correction of the Bid Price pursuant to Clause 27;

We undertake to pay to the Employer up to the above amount upon receipt of his first written demand, without the Employer having to substantiate his demand, provided that in his demand the Employer will note that the amount claimed by him is due to him owing to the occurrence of one or any of the three conditions, specifying the occurred condition or conditions.

This Guarantee will remain in force up to and including the date _____ 2 days after the deadline for submission of Bids as such deadline is stated in the Instructions to Bidders or as it may be extended by the Employer, notice of which extension(s) to the Bank is hereby waived. Any demand in respect of this Guarantee should reach the Bank not later than the above date.

Notwithstanding anything mentioned above,

Our liability against this guarantee is restricted to Rs (Rupees only) and unless a claim in writing is lodged with us within 3 months of the date of expiry or the extended date of expiry of this guarantee all our liabilities under this guarantee shall stand discharged.

IN WITNESS WHEREOF this guarantee _____ has been duly executed on this
day of 20

DATE _____ SIGNATURE OF THE BANK _____

WITNESS _____ SEAL _____

[Signature, name and address]

The Bidder should insert the amount of the guarantee in words and figures denominated in Indian Rupees. This figure should be the same as shown in Clause 16 of the Instructions to Bidders.

30 days after the end of the validity period of the Bid. Date should be inserted by the Employer before the Bidding documents are issued.

Annexure-10**DETAILS OF THE PARTY OPTING FOR REFUND OF EMD THROUGH E-PAYMENT SYSTEM FROM NEW MANGALORE PORT AUTHORITY**

Name of the Party :

Bank A/c No :

Account type : (Savings / Current / Overdraft)

Bank Name :

Branch :

IFSC Code Number : (11 digit code)

Centre (Location) :

FAX No. :

E-Mail ID : (For forwarding information of remittance)

Mobile No :

Signature of the Party

Annexure-11**FORMAT FOR FURNISHING BANK INFORMATION FOR e-PAYMENT**

1	Name and full address of the beneficiary	
2	Credit Account No. (Should be full 14 digit)	
3	Account Type (SB or CA or OD)	
4	Name of the Bank	
5	Branch (Full address with telephone No.)	
6	IFSC Code Number (11 digit)	
7	MICR code (Should be 9 digit)	
8	Telephone/Mobile/Fax No. of the beneficiary	Telephone:
		Mobile :
		Fax :
9	Photostat copy of a Cheque	

Signature of the party with seal

Verified the details furnished by the party and it is ascertained that the information furnished are in full shape as required. Xerox copy of a Cheque is also enclosed.

Signature of the HOD/HOO with seal

Annexure 12**INDEMNITY BOND**

(To be furnished in Stamp paper not less than Rs.200 e-Stamp paper)

This deed of indemnity is executed by herein after referred to as 'Indemnifier' which expression shall unless repugnant to the context or meaning thereof, include its successors, Administrator, representatives and assignees in favour of New Mangalore Port Authority, Panambur, Mangalore 575010, herein after referred to as 'Indemnified' which expression shall unless repugnant to the context or meaning thereof include its representatives and assignees witnesses as to.

Whereas the indemnified herein as awarded to the indemnifier herein a Tender/Contract or for supply of / Construction of on terms and conditions set out interalia in the work order No..... valued at Rs.....

AND Whereas, the clauses No..... of the above-mentioned work order provides for indemnifying the indemnified by the indemnifier for any accident, damage or compensation payable to any workmen or other person in the employment of the contractor or any sub-contractor during the period of tender/contract.

AND Whereas, the Indemnifier hereby irrevocably agrees to indemnify the indemnified against all damages or compensation payable at law in respect of or in consequence of any accident or injury to any workmen or other person in the employment of the contractor or sub-contractor against all claims, demands, proceedings, costs, charges and expenses whatsoever in respect thereof or in relation thereto and the indemnified shall be at liberty to deduct or adjust from the bills payable to the indemnifier by the indemnified for an amount that the indemnified may be called upon to pay towards claims, demands, proceedings, costs, charges and expenses whatsoever in respect of or in relation to any accident or injury referred to above without any reference to the indemnifier.

The Indemnifier shall comply with all the Central State and Muncipal Laws and Rules and shall be solely responsible for complying with the provisions of the Contract Labour (Regulations & Abolition) Act, 1970 & the contract labour (Regulation & Abolition) Karnataka Rules 1974 and rules there under and the enactments that may be applicable including ESI Act, the payment of wages act, Provident Fund Act, the Minimum Wages Act, the Factory's Act, the Workmen Compensation Act or any other applicable legislation and the Muncipal by-laws or other statutory Rules and Regulations whatsoever in force if these are applicable. Any obligations finding or otherwise missed under any statutory enactments rules & regulations there under shall be the responsibility of the Indemnifier and the Indemnified will have no responsibility for the same. The Indemnifier shall obtain Workmen's Compensation Policy for his workers, who are not covered under ESI and submit the same to the ESIC immediately after commencement of the work.

The Indemnifier is liable to pay all Statutory Compensation to the Labourers / persons engaged by him for the satisfactory execution of the works. If any claim is made against Indemnified arising out of this work, the Port shall have the right to deduct the same from the bill amount payable to the Indemnifier after verification of the validity and if admissible as per rules.

The Indemnifier shall ensure the use of PPE such as helmets, safety shoes, nose masks, hand gloves, safety harness or any other equipment as required depending on nature of work by his staff at site.

In addition to complying of the above, the Indemnifier hereby undertakes to indemnify the indemnified against any unforeseen incidents / accidents, which may lead to fatality including death, permanent/ partial disablement, injury, financial loss, legal issues or any other etc of the labourers / workmen's/ staffs of the contractor / sub-contractor for which the indemnified and its officers / representation are in no way responsible.

For.....

INDEMINIFIER

(Signature with Name and Designation)

Company Seal

Station:

Date:

Witness:

1.....

Signature with Name, Designation & Address

2.....

Signature with Name, Designation & Address

BID SECURITY DECLARATION FORM

Date: [insert date (as day, month and year)]

Bid No.: [insert number of bidding process]

To: [insert complete name of the Employer]

I/We. The undersigned, declare that:

I/We understand that, according to your conditions, bids must be supported by a Bid security declaration

I/We accept that we will automatically be disqualified from bidding for any contract with New Mangalore Port Authority for a period of 2 (Two) years starting from the date of notification from the Employer, if the undertaking of the affidavit submitted by us or our constituents in pursuance to any of the declarations of Letter of Technical Bid or Letter of Price Bid submitted by us are found to be false at any stage during the process of bid evaluation; or

I am / We are in a breach of any obligation(s) under the bid conditions, because I/We

- a) have withdrawn / modified / amended, impairs or derogates from the bid, my / our Bid during the period of bid validity specified in the form of Bid; or
- b) do not accept the correction of errors in accordance with the Instructions to Bidders; or
- c) having been notified of the acceptance of our Bid by the employer during the period of bid validity,
 - i. fail or refuse to execute the contract, if required; or
 - ii. fail or refuse to furnish the Performance Security, in accordance with the Instructions to Bidders; or
 - iii. fail or refuse to furnish a domestic preference security, if required.

I/We understand this Bid Security Declaration shall cease to be valid if I am/we are not the successful Bidder, upon the earlier of

- i. the receipt of your notification of the name of the successful Bidder; or
- ii. 28 (Twenty eight) days after the expiration of the validity of my/our Bid

Signed: [insert signature of person whose name and capacity are shown]

In the capacity of [insert legal capacity of person signing the Bid-Securing Declaration]

Name: [insert complete name of person signing the Bid-security Declaration]

Duly authorized to sign the bid for and behalf of [insert complete name of the Bidder]

Dated on _____ day of _____, _____ [insert date of Signing]

Corporate seal [where appropriate]

Annexure-14

**Format for Self Certification under Preference to “MAKE IN
INDIA” Policy**
(Refer Clause No. 38 of ITT)

CERTIFICATE

In line with Government Public Procurement Order No. P-45021/2/2017-PP(B-II) dtd. 16-09-2020, as amended from time to time and as applicable on the date of submission of tender, we hereby certify that we M/s _____ (name of the Bidder) are local supplier meeting the requirement of minimum Local content (50%) as defined in above orders for the material against Tender NIT No _____ for the work of

Details of location at which local value addition will be made is as follows:

We also understand, false declarations will be in breach of the Code of Integrity under Rule 175(1)(i)(h) of the General Financial Rule for which for which a bidder or its successors can be debarred for up two years as per Rule 151 (iii) of the General Financial Rules along with such other actions as may be permissible under law. Seal and Signature of Authorized Signatory

Signature of the Bidder

Date :

Place :

SECTION - II

ii) FORM OF AGREEMENT

THIS AGREEMENT made the _____ day of _____
 20___ BETWEEN New Mangalore Port Authority (hereinafter called "the Employer") of the
 one part and _____

(hereinafter called "the Contractor") of the other part WHEREAS the Employer is desirous that certain works should be executed by the Contractor, Viz----- and has accepted a Tender by the Contractor for the execution and Completion of such works and the remedying of any defects therein at a contract price of Rs

NOW THIS AGREEMENT WITNESSETH as follows:

1. In this Agreement words and expressions shall have the same meanings as are respectively assigned to them in the General Conditions hereinafter referred to.
2. The following documents shall be deemed to form and be read and construed as part of this Agreement, viz.-
 - a) The Letter of Acceptance;
 - b) The Said Tender (Technical Bid);
 - c) The Conditions of Contract (Parts I and II)
 - d) The Specifications;
 - e) The Drawings;
 - f) The Bill of Quantities and
 - g) The Addenda
- h) Letters exchanged between the Employer and the Tenderer up to the issue of Letter of Acceptance as separately listed and annexed here to.
3. In consideration of the payments to be made by the Employer to the contractor as hereinafter mentioned the Contractor hereby covenants with the Employer to execute and complete the works and remedy any defects therein in conformity in all respect with the provisions of the Contract.
4. The Employer hereby covenants to pay the Contractor in consideration of the execution and completion of the works and the remedying of defects therein the Contract Price or and such other sum as may become payable under the Provisions of the Contract at the times and in the manner prescribed by the Contract.

IN WITNESS whereof the parties hereto have caused this Agreement to be executed the day and year first above written in accordance with their respective laws.

This document contains pages in all. This agreement is assigned No. CEA /20XX-XX.

The Common Seal of

was hereunto affixed in the presence of:

iii) CONDITIONS OF CONTRACT

A. General

1. Definitions

Terms which are defined in the Contract Data are not also defined in the Conditions of Contract but keep their defined meanings. Capital initials are used to identify defined terms.

Bill of Quantities means the priced and completed Bill of Quantities forming part of the Bid.

Compensation Events are those defined in Clause 44.

The Completion Date is the date of completion of the Works as certified by the Engineer or his nominee in accordance with Sub Clause 54

The Contract is the contract between the Employer and the Contractor to execute, complete and maintain the Works. It consists of the documents listed in Clause 2.3 below.

The Contract Data defines the documents and other information which comprise the Contract.

The Contractor is a person or corporate body whose Bid to carry out the Works has been accepted by the Employer.

The Contractor's Bid is the completed Bidding documents submitted by the Contractor to the Employer.

The Contract Price is the price stated in the letter of acceptance and thereafter as adjusted in accordance with the provisions of the Contract.

Days are calendar days, months are calendar months.

A Defect is any part of the Works not completed in accordance with the Contract.

The Defects Liability Period is the period named in the Contract Data and calculated from the Completion Date.

The Employer is the party who will employ the Contractor to carry out the Works.

Equipment is the Contractor's machinery and vehicles brought temporarily to the Site to construct the Works.

The Initial Contract Price is the Contract Price listed in the Employer's Letter of Acceptance.

The Intended Completion Date is the date on which it is intended that the Contractor shall complete the works. The Intended Completion Date is specified in the Contract Data. The Intended Completion Date may be revised only by the Engineer or his nominee by issuing an extension of time.

Materials are all supplies, including consumables, used by the contractor for incorporation in the Works.

The Engineer or his nominee is the person named in the Contract Data (or any other

competent person appointed and notified to the contractor to act in replacement of the Engineer or his nominee) who is responsible for supervising the Contractor, administering the Contract, certifying payments due to the Contractor, issuing and valuing Variations to the Contract, awarding extensions of time and valuing the Compensation Events.

Plant is any integral part of the Works which is to have mechanical, electrical, electronic or chemical or biological function.

The Site is the area defined as such in the Contract Data.

Site Investigation Reports are those which are included in the Bidding documents and are factual interpretative reports about the surface and sub-surface conditions at the site.

Specification means the Specification of the Works included in the Contract and any modification or addition made or approved by the Engineer or his nominee.

The Start Date is given in the Contract Data. It is the date when the Contractor shall commence execution of the works. It does not necessarily coincide with any of the Site Possession Date.

A Subcontractor is a person or corporate body who has a Contract with the Contractor to carry out a part of the work in the Contract which includes work on the Site.

Temporary Works are works designed, constructed, installed and removed by the Contractor which are needed for construction or installation of the Works.

A Variation is an instruction given by the Engineer or his nominee which varies the Works.

The Works are what the Contract requires the Contractor to construct, install and turn over to the Employer as defined in the Contract Data.

The Trained Work Person are those employed / proposed to be employed by the Contractor at the Project Site, who have participated and are in possession of a valid Competency Certificate through a programme run under the auspices of a University, State Technical Board, Ministry of Government of India.

2. Interpretation

- 2.1 In interpreting these Conditions of Contract, singular also means plural, male also means female or neuter and the other way around. Headings have no significance. Words have their normal meaning under the language of the Contract unless specifically defined. The Engineer or his nominee will provide instructions clarifying queries about the Conditions of Contract.
- 2.2 If sectional completion is specified in the Contract Data, references in the Conditions of Contract to the Works, the Completion Date, and the Intended Completion Date apply to any Section of the Works (other than references to the Completion Date and Intended Completion date for the whole of the Works).
- 2.3 The documents forming the Contract shall be interpreted in the following order

of priority:

- (1) Agreement
- (2) Letter of Acceptance and notice to proceed with works
- (3) Contractor's Bid
- (4) Contract Data
- (5) Conditions of Contract including Special Conditions of Contract
- (6) Specifications
- (7) Drawings
- (8) Bill of quantities and
- (9) any other documents listed in the Contract Data as forming part of the Contract.

3. Language and Law

- 3.1 The language of the Contract and the law governing the Contract are stated in the Contract Data.

4. Engineer or his nominee's Decisions

- 4.1 Except where otherwise specifically stated, the Engineer or his nominee will decide contractual matters between the Employer and the Contractor in the role representing the Employer.

5. Delegation

- 5.1 The Engineer or his nominee may delegate any of the duties and responsibilities to other people after notifying the Contractor and may cancel any delegation after notifying the Contractor.

6. Communications

Communications between parties which are referred to in the conditions are effective only when in writing. A notice shall be effective only when it is delivered (in terms of Indian Contract Act 1872).

7. Contract Agreement

A suitable form is annexed as "FORM OF AGREEMENT" to the Contract Document. Upon signing the Contract Agreement, the Contractor shall make 12 copies of Contract Documents in hardbound cover which shall cover documents used in Contract/Agreement and provide the same to the Employer at no extra cost. No work shall be commenced without signing contract agreement. Data made available by the Employer in accordance with provisions of the Condition of Contract shall be deemed to include data listed elsewhere in the Contract and open for inspection at the office of the Deputy Chief Engineer (Civil) of the New Mangalore Port Authority (by prior appointment with the Engineer).

8. Subcontracting

- 8.1 The Contractor may subcontract with the approval of the Engineer or his nominee but may not assign the Contract without the approval of the Employer in writing. Subcontracting does not alter the Contractor's obligations.

Other Contractors

- 8.2 The Contractor shall co-operate and share the site with other contractors, public authorities, utilities, and the Employer between the dates given in the Schedule of other contractors. The Contractor shall as referred to in the Contract Data, also provide facilities and services for them as described in the Schedule. The employer may modify the schedule of other contractors and shall notify the contractor of any such modification.

9. Personnel

- 9.1 The Contractor shall employ the key personnel named in the Schedule of Key Personnel as referred to in the Contract Data to carry out the functions stated in the Schedule or other personnel approved by the Engineer or his nominee. The Engineer or his nominee will approve any proposed replacement of key personnel only if their qualifications, abilities, and relevant experience are substantially equal to or better than those of the personnel listed in the schedule.
- 9.2 If the Engineer or his nominee asks the contractor to remove a person who is a member of the contractor's staff of his work force stating the reasons, the contractor shall ensure that the person leaves the site within seven days and has no further connections with the work in the contract.

10. Employer's and Contractor's Risks

- 10.1 The Employer carries the risks which this Contract states are Employer's risks and the contractor carries the risks which this Contract states are contractor's risks.

11. Employer's Risks

- 11.1 The Employers risks are
- a) in so far as they directly affect the execution of the Works in the country where the Permanent Works are to be executed:
 - i) war and hostilities (whether war be declared or not), invasion, act of foreign enemies;
 - ii) rebellion, revolution, insurrection, or military or usurped power, or civil war;
 - iii) ionizing radiations, or contamination by radioactivity from any nuclear fuel, or from any nuclear waste, from the combustion of nuclear fuel, radioactive toxic explosive or other hazardous properties of any explosive nuclear assembly or

- nuclear component thereof;
- iv) pressure waves caused by aircraft or other aerial devices travelling at sonic or supersonic speeds; and
 - v) riot, commotion or disorder, unless solely restricted to the employees of the Contractor or of his Subcontractors and arising from the conduct of the Works;
 - vi) Unforeseen Rains (Rains if any; during the period other than the Monsoon period as stated in the Tender), floods, tornadoes, earthquakes and landslides.
- b) loss or damage due to the use or occupation by the Employer of any Section or part of the Permanent Works, except as may be provided for in the Contract;
 - c) loss or damage to the extent that it is due to the design of the Works, other than any part of the design provided by the Contractor or for which the Contractor is responsible; and
 - d) any operation of the forces of nature (in so far as it occurs on the Site) which an experienced contractor:
 - i) could not have reasonably foreseen, or
 - ii) could reasonably have foreseen, but against which he could not reasonably have taken at least one of the following measures:
 - A) prevent loss or damage to physical property from occurring by taking appropriate measures, or
 - B) insure against.

12. Contractor's Risks

- 12.1 All risks of loss of or damage to physical property and of personal injury and death which arise during and in consequence of the performance of the Contract other than the excepted risks are the responsibility of the Contractor.

13. Insurance

- 13.1 The Contractor shall provide in the joint names of the Employer and the Contractor, insurance cover from the Start Date to the end of the Defects Liability Period, in the amounts and deductibles stated in the Contract Data for the following events which are due to the Contractors risks.
- a) loss of or damage to the Works, Plant and Materials
 - b) loss of or damage to Equipment;
 - c) loss of or damage of property (except the Works, Plant, Materials and Equipment) in connection with the Contract; and
 - d) personal injury or death.
- 13.2 Policies and certificates for insurance shall be delivered by the contractor to the Engineer or his nominee for the Engineer or his nominee's approval before the start date. All such insurances shall provide for compensation to be payable in the types and proportions of currencies required to rectify the loss or damage

incurred.

- 13.3 If the contractor does not provide any of the policies and certificates required, the Employer may affect the insurance which the contractor should have provided and recover the premiums the Employer has paid from payments otherwise due to the contractor or, if no payment is due, the payment of the premiums shall be a debt due.
- 13.4 Alterations to the terms of insurance shall not be made without the approval of the Engineer or his nominee.
- 13.5 Both parties shall comply with all conditions of the insurance policies.

14. Site Investigation Reports

The Contractor, in preparing the Bid, shall rely on the Site Investigation Report referred to in the Contract Data, supplemented by any information available to the Bidder.

15. Queries about the Contract Data

The Engineer or his nominee will clarify queries on the Contract Data.

16. Contractor to Construct the Works

The Contractor shall construct and install the works in accordance with the Specification and Drawings.

17. The Works to Be Completed by the Intended Completion Date

The Contractor may commence execution of the works on the Start Date and shall carry out the works in accordance with the program submitted by the contractor as updated with the approval of the Engineer or his nominee, and complete them by the Intended Completion Date.

18. Approval by the Engineer or his nominee

- 18.1 The Contractor shall submit Specifications and Drawings showing the proposed Temporary Works to the Engineer or his nominee, who is to approve them if they comply with the specifications and Drawings.
- 18.2 The Contractor shall be responsible for design of Temporary Works.
- 18.3 The Engineer or his nominee's Approval shall not alter the contractor's responsibility for design of the Temporary Works.
- 18.4 All Drawings prepared by the contractor for the execution of the temporary or permanent Works, are subject to prior approval by the Engineer or his nominee before their use.

19. Safety

The contractor shall be responsible for the safety of all activities on the Site.

20. Discoveries

Anything of historical or other interest or of significant value unexpectedly discovered on the Site is the property of the Employer. The Contractor is to notify the Engineer or his nominee of such discoveries and carry out the Engineer or his nominee's instructions for dealing with them.

21. Possession of the Site

The Employer shall give possession of all parts of the Site to the Contractor, free from encumbrances. If possession of a part is not given by the start date stated in the Contract Data the Employer is deemed to have delayed the start of the relevant activities and this will be a Compensation Event.

22. Access to the Site

The Contractor shall allow the Engineer or his nominee and any person authorised by the Engineer or his nominee access to the Site to any place where work in connection with the Contract is being carried out or is intended to be carried out and to any place where materials or plant are being manufactured, fabricated and/or assembled for the works.

23. Instructions

The Contractor shall carry out all instructions of the Engineer or his nominee which comply with the applicable laws where the Site is located.

24. Disputes

If the Contractor believes that a decision taken by the Chief Engineer (Civil) or his Representative was either outside the authority given to the Chief Engineer (Civil) or his Representative by the Contract or that the decision was wrongly taken or there is no decision within a calendar month, the decision shall be referred to the Conciliation Settlement Committee (CSC) to be Constituted by the Indian Ports Association as per the guidelines dated 24.09.2021 within 30 days of the notification of the Chief Engineer (Civil) or his Representative decision or upon expiry of a calendar month as the case may be.

25. Settlement of Disputes**25.1 Amicable Settlement/ Conciliation and Settlement Committee**

Disputes of any kind arising between the Board of NMPA and the Contractor in connection with, or arising out of the Contract or the execution of the contract whether during the execution of the contract or after the completion and whether before or after repudiation or termination of the Contract, including any dispute as to any opinion, decision, instruction, determination, certificate, payment, or valuation under the contract, the matter in dispute shall in the first place, be referred in writing to the Chief Engineer (Civil) NMPA or his

nominee/representative and an attempt shall first be made by all the parties to settle such disputes amicably by serving a copy of such reference in writing to the other party and such reference shall state that it is made pursuant to this clause.

If the Contractor believes that a decision taken by the Chief Engineer (Civil) or his Representative was either outside the authority given to the Chief Engineer (Civil) or his Representative by the Contract or that the decision was wrongly taken or there is no decision within a calendar month, the decision shall be referred to the Conciliation Settlement Committee (CSC) to be Constituted by the Indian Ports Association as per the guidelines dated 24.09.2021 within 30 days of the notification of the Chief Engineer (Civil) or his Representative decision or upon expiry of a calendar month as the case may be.

Unless the Contract has already been repudiated or terminated, the Contractor shall, in every case, continue to proceed with the Works with all due diligence and the Contractor and the Principal Employer shall give effect forthwith to every such decision of the Chief Engineer (Civil) unless and until the same shall be revised, as hereinafter provided, in a CSC or an arbitral award.

Provided that, unless the parties otherwise, have exhausted the above remedies under the amicable Settlement proviso and the CSC, the parties shall not invoke arbitration before the expiry of Thirty days after the day on which the notice of failure to settle such dispute was given by the CSC.

25.2 Procedure of Arbitration:

Except where otherwise provided for in the contract, all questions and disputes relating to the meaning of the words, terms, specifications, operations, and instructions, mentioned in this contract and as to the quality of workmanship or performance of handling and any other question, claim, right, matter or thing whatsoever in any way arising out of or relating to the contract, specifications, operating instructions, orders or these conditions; or otherwise concerning the transport and handling operations, the execution or failure to execute the same whether arising during the progress of the work or after the completion or abandonment thereof, shall be referred to a sole arbitrator to be appointed by the Tender Accepting Authority of NMPA. There will be no objection if the sole arbitrator so appointed is not ineligible for being appointed as an arbitrator under the fifth & sixth schedule of the Arbitration & conciliation Act 1996.

If the Arbitrator, to whom the matter is originally referred, is transferred or vacates his office or is unable to act for any reason, the Tender Accepting Authority of NMPA, as aforesaid at the time of such transfer, or vacation of the office or inability to act, shall appoint another person to act as Arbitrator in accordance with the terms of the contract. Such person shall be entitled to

proceed with the reference from the stage, at which it was left by his predecessor.

Subject to as aforesaid, the provisions of the Arbitration and Conciliation Act 1996 and the amended provisions thereto, or any statutory modification or re-enactment thereof, and the rules made there under, and for the time being in force shall apply to the arbitration proceedings under this clause.

It is a term of the contract that the party invoking arbitration shall specify the disputes to be referred to arbitration under this clause together with the amount or amounts claimed in respect of each dispute.

The work under the contract shall, if reasonably possible, continue during the arbitration proceedings and no payment due or payable to the contractor shall be withheld on account of such arbitration proceedings.

The Arbitrator shall be deemed to have entered on the reference on the date on which he issues notices to both the parties fixing the date of the first hearing.

The Arbitrator shall have power to call for such evidence by way of affidavits or otherwise as the Arbitrator shall think proper and it shall be the duty of the parties hereto to do or cause to be done all such things as may be necessary to enable the Arbitrator to pass the award without any delay.

The Arbitrator shall give a separate award in respect of each dispute or difference referred to him. The venue of arbitration shall be at Panambur, Mangalore. The award of the Arbitrator shall be final, conclusive and binding on all parties to the contract. The Courts at Mangalore shall only have the Jurisdiction to entertain Arbitration Suits/ Arbitration Applications.

26. Replacement of conciliator (deleted)

B. TIME CONTROL

27. Program

- 27.1 Within the time stated in the Contract Data the Contractor shall submit to the Engineer or his nominee for approval a Program showing the general methods, arrangements, order, and timing for all the activities in the works along with monthly cash flow forecast.
- 27.2 An update of the Program shall be a program showing the actual progress achieved on each activity and the effect of the progress achieved on the timing of the remaining work including any changes to the sequence of the activities.
- 27.3 The Contractor shall submit to the Engineer on the first day of each week or such longer period as the Engineer may from time to time direct, a progress report in an approved form showing up-to-date total progress, progress achieved against planned progress, during the previous week and progress forecast for the following week for all important items in each section or portion of the Works, in relation with the approved Program.
- 27.4 The Contractor shall submit to the Engineer or his nominee, for approval an updated Program at intervals no longer than the period stated in the Contract Data. If the Contractor does not submit an updated Program within this period, the Engineer or his nominee may withhold the amount stated in the Contract Data from the next payment certificate and continue to withhold this amount until the next payment after the date on which the overdue Program has been submitted.

28. Revised Program

The Engineer or his nominee's approval of the Program shall not alter the Contractor's obligations. The Contractor may revise the Program and submit it to the Engineer or his nominee again at any time. A revised Program is to show the effect of Variations and Compensation Events.

29. Extension of the Intended Completion Date

- 29.1 The Engineer or his nominee shall extend the Intended Completion Date if a Compensation Event occurs or a Variation is issued which makes it impossible for Completion to be achieved by the Intended Completion Date without the Contractor taking steps to accelerate the remaining work and which would cause the Contractor to incur additional cost.
- 29.2 The Engineer or his nominee shall decide whether and by how much to extend the Intended Completion Date within 21 days of the Contractor asking the Engineer or his nominee for a decision upon the effect of a Compensation Event or Variation and submitting full supporting information. If the Contractor has failed to give early warning of a delay or has failed to cooperate in dealing

with a delay, the delay by this failure shall not be considered in assessing the new Intended Completion Date.

30. Delays Ordered by the Engineer or his nominee

The Engineer or his nominee may instruct the Contractor to delay the start or progress of any activity within the Works.

31. Management Meetings

- 31.1 Either the Engineer or his nominee or the Contractor may require the other to attend a management meeting. The business of a management meeting shall be to review the plans for remaining work and to deal with matters raised in accordance with the early warning procedure.
- 31.2 The Engineer or his nominee shall record the business of management meetings and is to provide copies of his record to those attending the meeting and to the Employer. The responsibility of the parties for actions to be taken is to be decided by the Engineer or his nominee either at the management meeting or after the management meeting and stated in writing to all who attended the meeting.

32. Early Warning

- 32.1 The Contractor is to warn the Engineer or his nominee at the earliest opportunity of specific likely future events or circumstances that may adversely affect the quality of the work, increase the Contract Price or delay the execution of works. The Engineer or his nominee may require the Contractor to provide an estimate of the expected effect of the event or circumstance on the Contract Price and Completion Date. The estimate is to be provided by the Contractor as soon as reasonably possible.
- 32.2 The Contractor shall cooperate with the Engineer or his nominee in making and considering proposals for how the effect of such an event or circumstance can be avoided or reduced by anyone involved in the work and in carrying out any resulting instruction of the Engineer or his nominee.

C. QUALITY CONTROL

33. Identify Defects

The Engineer or his nominee shall check the Contractor's work and notify the Contractor of any Defects that are found. Such checking shall not affect the Contractor's responsibilities. The Engineer or his nominee may instruct the Contractor to search for a Defect and to uncover and test any work that the Engineer or his nominee considers may have a Defect.

34. Tests

If the Engineer or his nominee instructs the Contractor to carry out a test not specified in the Specification to check whether any work has a Defect and the test shows that it does the Contractor shall pay for the test and any samples. If there is no Defect the test shall be a Compensation Event.

35. Defect Liability

35.1 The Engineer or his nominee shall give notice to the Contractor of any Defects before the end of the Defects Liability Period, which begins at Completion and is defined in the Contract Data. The Defects Liability Period shall be extended for as long as Defects remain to be corrected.

35.2 Every time notice of a Defect is given, the Contractor shall correct the notified defect within the length of time specified by the Engineer or his nominee's notice. To the intent that the works shall, at or as soon as practicable after the expiration of the Defects Liability Period, be delivered to the Employer in the condition required by the Contract, fair wear and tear excepted, to the satisfaction of the Engineer, the Contractor shall :

- (a) Complete the work, if any, outstanding on the date stated in the Taking-Over Certificate within the date to be intimated by the engineer and
- (b) execute all such work of amendment, reconstruction, and remedying defects, shrinkages or other faults as the Engineer may, during the Defects Liability Period or within 14 days after its expiration, as a result of an inspection made by or on behalf of the Engineer prior to its expiration, instruct the Contractor to execute.

35.3 Cost of Remedying Defects

All work referred to in Sub-Clause 35.2 shall be executed by the contractor at his own cost if the necessity thereof is, in the opinion of the Engineer, due to:

- a) The use of materials, Plant or workmanship not in accordance with the Contract, or
- b) Where the Contractor is responsible for the design of part of the Permanent Works, any fault in such design, or the neglect or failure on the part of the Contractor to comply with any obligation, expressed or implied, on the Contractor's part under the Contract.

35.4 Defects Liability Certificate

The Contract shall not be considered as completed until a Defects Liability Certificate shall have been signed by the Engineer and delivered to the Employer, with a copy to the Contractor, stating the date on which the Contractor shall have completed his obligations to execute and complete the Works and remedy any defects therein to the Engineer's satisfaction. The Defects Liability Certificate shall be given by the Engineer within 28 days after the expiration of the Defects Liability Period, or, if different defects liability periods shall become applicable to different Sections or parts of the Permanent Works, the expiration of the latest such period, or as soon thereafter as any works instructed, pursuant to Clauses 35, have been completed to the satisfaction of the Engineer.

35.5 Unfulfilled Obligations

Notwithstanding the issue of the Defects Liability Certificate the Contractor and the Employer shall remain liable for the fulfillment of any obligation incurred under the provisions of the Contract prior to the issue of the Defects Liability Certificate which remains unperformed at the time such Defects Liability Certificate is issued and, for the purposes of determining the nature and extent of any such obligation, the Contract shall be deemed to remain in force between the parties to the Contract.

36. Uncorrected Defects.

If the Contractor has not corrected a Defect within the time specified in the Engineer or his nominee's notice the Engineer or his nominee will assess the cost of having the Defect corrected, and the Contractor will pay this amount.

D. COST CONTROL

37. Bill of Quantities

- 37.1 The Bill of Quantities shall contain items for the construction, supply, installation, testing and commissioning work to be done by the Contractor.
- 37.2 The Bill of Quantities is used to calculate the Contract Price. The Contractor is paid for the quantity of the work done at the rate in the Bill of Quantities for each item.

38. Changes in the Quantities

- 38.1 If the final quantity of the work done differs from the quantity in the Bill of Quantities for the particular item by more than +25 % provided the change exceeds +10% of initial Contract Price, the Engineer or his nominee shall adjust the rate(s), to allow for the change.
- 38.2 The Engineer or his nominee shall not adjust rates from changes in quantities if thereby the Initial Contract Price is exceeded by more than 15 percent except with the Prior approval of the Employer.
- 38.3 If requested by the Engineer or his nominee where the quoted rate(s) of any item(s) is abnormally high, the Contractor shall provide the Engineer or his nominee with a detailed cost breakdown of such rate in the Bill of Quantities.

39. Variations

- 39.1 The Engineer shall make any variation of the form, quality or quantity of the Works or any part thereof that may, in his opinion, be necessary and for that purpose, or if for any other reason it shall, in his opinion, be appropriate, he shall have the authority to instruct the Contractor to do and the Contractor shall do any of the following:
- a) increase or decrease the quantity of any work included in the Contract,
 - b) omit any such work,
 - c) change the character or quality or kind of any such work,
 - d) change the levels, lines, position and dimension of any part of the Works,
 - e) execute additional work of any kind necessary for the completion of the Works,
 - f) change any specified sequence or timing of construction of any part of the Works.

No such variation shall in any way vitiate or invalidate the Contract, by the effect, if any, of all such variations shall be valued in accordance with Clause 40. Provided that where the issue of an instruction to vary the works is necessitated by some default of or breach of contract by the contractor or for which he is responsible, any additional cost attributable to such default shall be borne by the contractor. All Variations shall be included in updated Programs

produced by the contractor.

39.2 Instructions for Variations

The Contractor shall not make any such variation without an instruction of the Engineer. Provided that no instruction shall be required for increase or decrease in the quantity of any work where such increase or decrease is not the result of an instruction given under this clause, but is the result of the quantities exceeding or being less than those stated in the Bill of Quantities.

40. Payments for Variations

- 40.1 Variation permitted shall not exceed +25% in quantity of each individual item, and +10% of the total contract price. Within 14 days of the date of instruction for executing varied work, extra work or substitution, and before the commencement of such work, notice shall be given either (a) by the contractor to the Employer of his intention to claim extra payment or a varied rate or price, or (b) by the Employer to the contractor of his intention to vary rate or price.
- 40.2 For items not existing in the Bill of Quantities or substitution to items in the Bill of Quantities, rate payable should be determined by methods given below and, in the order, given below:
- i) Rates and prices in Contract, if applicable plus escalation as per contract.
 - ii) Rates and prices in the Schedule of Rates applicable to the Contract plus ruling percentage.
 - iii) Market rates of materials and labor, hire charges of plant and machinery used, plus 10% for overheads and profits of contractor.
- 40.3 For items in the Bill of Quantities but where quantities have increased beyond the variation limits, the rate payable for quantity in excess of the quantity in the Bill of Quantity plus the permissible variation should be:
- i) Rates and prices in contract, if reasonable plus escalation, failing which (ii) and (iii) below will apply
 - ii) Rates and prices in the schedule of Rates applicable to the contract plus ruling percentage.
 - iii) Market rates of material and labor, hire charges of plant and machinery used plus 10% for overheads and profits of contractor.
- 40.4 If there is delay in the Employer and the Contractor coming to an agreement on the rate of an extra item, rates as proposed by the Employer shall be payable provisionally till such time as the rates are finally determined or till date mutually agreed.
- 40.5 If the Engineer or his nominee decides that the urgency of varying the work prevent a quotation being given and considers not delaying the work, no quotation shall be given and the Variation shall be treated as a Compensation Event.

41. Cash flow forecasts

- 41.1 When the Program is updated, the contractor is to provide the Engineer or his nominee with an updated cash flow forecast.

42. Payment Certificates

- 42.1 The Contractor shall submit to the Engineer or his nominee monthly statements of the estimated value of the work completed less the cumulative amount certified previously.
- 42.2 The Engineer or his nominee shall check the Contractors' monthly statement within 14 days and certify the amount to be paid to the Contractor after taking into account any credit or debit for the month in question in respect of materials for the works in the relevant amounts and under conditions set forth in sub-clause 51.6 of the Contract Data (Secured Advance).
- 42.3 The value of work executed shall be determined by the Engineer or his nominee.
- 42.4 The value of work executed shall comprise the value of the quantities of the items in the Bill of quantities completed.
- 42.5 The value of work executed shall include the valuation of variations and Compensation Events.
- 42.6 The Engineer or his nominee may exclude any item certified in a previous certificate or reduce the proportion of any item previously certified in any certificate in the light of later information.

43. Payments

- 43.1 The bills for other Construction/Renovation/Miscellaneous works which are not paid on monthly basis the Contractor has to submit the bill within 7 days of joint measurement taken along with the concerned Engineer. The Engineer has to ensure that joint measurement to be completed within 7 days of completing of part work / running work. The concerned Engineer i/c shall check and make entries into bill/M.B within 10 days of submission of the interim bill and submit to Executive Engineer/ Superintending Engineer (Civil). The Executive Engineer/ Superintending Engineer (Civil) shall check the bills and after certification of the quantities as per manual shall forward to the Finance Department within 3 working days. The Contractor and Assistant Engineer both jointly complete the measurements, if Contractor due to any reason does not attend/avoid joint survey/measurements the Executive Engineer shall give notice to the contractor to be present at the site for joint measurement within 7 days notice. If the contractor fails to attend the joint measurement second notice shall be issued to the contractor to attend the joint measurement within 3 days failure to attend the site for joint measurement the Assistant Engineer and AEE or EE would record the reason and complete the measurements in a transparent manner departmentally and submit the bill.
- Bills / Tax invoice shall be prepared and submitted by the Contractor. Joint measurements shall be taken continuously and need not be connected with billing stage. System of 4 copies of measurements, one each for Contractor, Employer and Engineer or his nominee, and signed by both Contractor and Employer shall be followed.
- 43.2 Interim of bill amount will be paid within 14 days of submission of the bill.
- 43.3 Contractor shall submit final Bill within 60 days from the date of completion of work and the same will be paid by the Port within 30 days from the date of submission
- 43.4 The payment will be made to the contractor after deducting any dues payable to the Port statutory authorities etc
- 43.5 If an amount certified is increased in a later certificate as a result of an award by the DRB or an Arbitrator, the Contractor shall be paid interest upon the delayed payment as set out in this clause. Interest shall be calculated from the date upon which the increased amount would have been certified in the absence of dispute.
- 43.6 Items of the Works for which no rate or price has been entered in will not be paid for by the Employer and shall be deemed covered by other rates and prices in the Contract.

44. Compensation Events

- 44.1 The following mutually agreed Compensation Events unless they are caused by the Contractor would be applicable:
- (a) The Employer does not give access to a part of the Site by the Site Possession Date stated in the Contract Data.
 - (b) The Employer modifies the schedule of other contractors in a way which affects the work of the contractor under the contract.
 - (c) The Engineer or his nominee orders a delay or does not issue drawings, specifications or instructions required for execution of works on time.
 - (d) The Engineer or his nominee instructs the Contractor to uncover or to carry out additional tests upon work which is then found to have no Defects.
 - (e) The Engineer or his nominee unreasonably does not approve for a subcontract to be let.
 - (f) Ground conditions are substantially more adverse than could reasonably have been assumed before issuance of Letter of Acceptance from the information issued to Bidders (including the Site Investigation Reports), from information available publicly and from a visual inspection of the site.
 - (g) The Engineer or his nominee gives an instruction for dealing with an unforeseen condition, caused by the Employer, or additional work required for safety or other reasons.
 - (h) Other contractors, public authorities, utilities or the Employer does not work within the dates and other constraints stated in the Contract that cause delay or extra cost to the Contractor.
 - (i) The effect on the Contractor of any of the Employer's Risks.
 - (j) Other Compensation Events listed in the Contract Data or mentioned in the contract.

Whenever any compensation event occurs, the contractor will notify the employer, within 14 days and provide a forecast cost of the compensation event.

- 44.2 If a Compensation Event would cause additional cost or would prevent the work being completed before the Intended Completion Date, the Contract Price shall be increased and/or the Intended Completion Date shall be extended. The Engineer or his nominee shall decide whether and by how much the Contract Price shall be increased and whether and by how much the Intended Completion Date shall be extended.
- 44.3 As soon as information demonstrating the effect of each Compensation Event upon the Contractor's forecast has been provided by the Contractor, it is to be assessed by the Engineer or his nominee and the Contract Price shall be adjusted accordingly. If the Contractor's forecast is deemed unreasonable the Engineer or his nominee shall adjust the Contract Price based on Engineer or

his nominee's own forecast. The Engineer or his nominee will assume that the Contractor will react competently and promptly to the event.

45. Tax

- 45.1 The rates quoted by the Contractor to be inclusive of taxes if any excluding GST that the Contractor will have to pay for the performance of this Contract. The Employer will perform such duties in regard to the deduction of such taxes at sources as per applicable law. Any new Taxes, levies, duties imposed after signing the Contract shall be reimbursed by the employer on production of documentary evidence. The GST shall be quoted separately in tax invoice. The contractor shall file the applicable returns with tax department in time and submit the same as documentary evidence.

46. Currencies

- 46.1 All payments shall be made in Indian Rupees unless specifically mentioned.

47. Price Adjustment. (Not Applicable)

48. Retention

- 48.1 The Employer shall retain from each payment due to the Contractor the proportion stated in the Contract Data until Completion of the whole of the Works.
- 48.2 Retention Money shall be deducted at the rate of 10% of the total tax invoice, from first Running Bill onwards subject to a max of 5% plus of the contract price including GST. Retention money shall be refunded after completion of defect liability period along with performance security.

49. Liquidated Damages

- 49A In case of delay in completion of the contract, liquidated damages (L.D) may be levied at the rate of half per cent ($\frac{1}{2}\%$) of the contract price per week of delay, or part thereof subject to a maximum of 10 per cent of the contract price.
- 49A(i) The Employer, if satisfied, that the works can be completed by the contractor within a reasonable time after the specified time for completion, may allow further extension of time at its discretion with or without the levy of L.D. In the event of extension granted being with L.D, the Employer will be entitled without prejudice to any other right or remedy available in that behalf, to recover from the contractor as agreed damages equivalent to half per cent ($\frac{1}{2}\%$) of the contract value of the works including GST for each week or part of the week subject to the ceiling defined in sub-Clause 49 A.
- In the event of forfeiting the LD / EMD / SD performance Guarantee and while imposing penalty GST at applicable rate is applicable.

- 49A(ii) The Employer, if not satisfied that the works can be completed by the contractor, and in the event of failure on the part of the contractor to complete work within further extension of time allowed as aforesaid, shall be entitled, without prejudice to any other right, or remedy available in that behalf, to rescind the contract.
- 49A(iii) The Employer, if not satisfied with the progress of the contract and in the event of failure of the contractor to recoup the delays in the mutually agreed time frame, shall be entitled to terminate the contract.
- 49A(iv) In the event of such termination of the contract as described in clauses 49A(ii) or 49A(iii) or both the Employer shall be entitled to recover L.D. up to ten per cent (10%) of the contract value and forfeit the security deposit made by the contractor besides getting the work completed by other means at the risk and cost of the contractor.
- 49A(v) In case Part / portions of the work can be commissioned and the Port operates the portion for commercial purposes, the rate of LD will be restricted to the uncompleted value of work, the maximum LD being on the entire contract value.

50. Nominated Subcontractors

All specialists, merchants, tradesmen and others executing any work or supplying any good, materials, Plant or services for which provisional Sums are included in the Contract, who may have been or be nominated or selected or approved by the Employer or the Engineer, and all persons to whom by virtue of the provisions of the Contract, the Contractor is required to subcontract shall, in the execution of such work or the supply of such goods, materials, Plant or services, be deemed to be subcontractors to the Contractor and are referred to in this Contract as "Nominated Subcontractors".

51. Advance payment (Not Applicable)

The Employer shall make the following advance payments:

- 51.1 Mobilisation Advance shall be paid up to 10% of Contract price, payable in two equal installments. The first installment shall be paid after mobilisation has started and next installment shall be paid after satisfactory utilisation of earlier advance.
- 51.2 Construction / installation equipment Advance shall be paid up to 5% of Contract price, limited to 90% of assessed cost of machinery.
- 51.3 Mobilisation Advance and Construction Equipment Advance shall be paid at SBI PLR + 2% p.a. (as on date of payment) interest rate at the discretion of the employer and against Bank Guarantee for Mobilisation Advance and against hypothecation of Construction Equipment to the Employer.
- 51.4 Equipment advance will be paid in two or more installments. First installment

shall be paid after Construction Equipment has arrived at the site and next installment shall be paid after satisfactory utilisation of earlier advance (s).

51.5 Recovery of Mobilisation and Construction Equipment advance will start when 15% of the work is executed and recovery of total advance should be completed by the time 80% of the original Contract work is executed.

51.6 Secured Advance :The Engineer or his nominee shall make advance payment in respect of materials and plant brought to site but not yet incorporated and installed in the Works in accordance with conditions stipulated in the Contract Data.

75% of cost of materials and plant brought to site for incorporation into the works only shall be paid as Secured Advance. Materials which are of perishable nature should be adequately insured.

52. Securities

52.1 Security deposit shall consist of two parts

- g) Performance security to be submitted at award of the work
- h) Retention Money to be recovered from Running Bills.

52.2 The Security deposit at 10% of the contract amount including GST, of which 5% of contract price should be submitted as Performance Security within 21 days of receipt of letter of acceptance and balance 5% recovered as retention money from running bills. Recovery of 5% of retention money shall commence from the first RA bill onwards @ 10% for each bill. Retention money shall be refunded after completion of defect liability period. The performance Bank Guarantee will be released after completion of defect liability period.

53. Removal of Craft or Plant which has sunk (not applicable)

The Contractor shall forthwith and with dispatch at his own cost raise and remove any craft or plant (floating or otherwise) belonging to him or to any sub-contractor employed by him (including also any plant which is held by the Contractor or any sub-contractor under agreement for hire or hire-purchase) which may be sunk in the course of the construction completion or maintenance of the Works or otherwise deal with the same as the Engineer may direct or until the same shall be raised and removed, the contractor shall set al such buoys and display at night such lights and do all such things for the safety of navigation as may be required by the Engineer or by Employer. In the event of the Contractor not carrying out his obligation imposed upon him by this clause the Employer may provide buoy and light such sunken craft or plant and raise and remove the same (without prejudice to the right of the Employer to hold the Contractor liable under General Conditions) and the Contractor shall refund to the Employer all costs incurred in connection therewith.

Contractor's Temporary Moorings

Should the Contractor need, in connection with implementing the Works, to provide temporary moorings for his craft he may be allowed to do so in location and manner approved by the Engineer subject to all necessary permissions being first obtained by the Contractor from the authorities concerned. The Contractor shall not lay his temporary moorings such as to interfere with the port traffic and such moorings shall be removed if and when required by the Employer.

54. Cost of Repairs

53.1 Loss or damage to the Works or Materials to be incorporated in the Works between the Start Date and the end of the Defects Correction period shall be remedied by the Contractor at the Contractor's cost if the loss or damage arises from the Contractor's acts or omissions.

E. FINISHING THE CONTRACT

55. Completion

After completion of the work, the contractor will serve a written notice to the Engineer or his nominee/Employer to this effect. The Engineer or his nominee/Employer upon receipt of this notice shall conduct a complete joint survey of the work within 7 days and prepare a defects list jointly. The defects pointed out by the Engineer or his nominee/Employer would be rectified by the contractor within 14 days and thereafter acceptance report be signed jointly by the contractor and the Employer. This joint acceptance report shall be treated as 'Completion Certificate'.

Substantial Completion of Parts

If any part of the Permanent Works has been substantially completed and satisfactorily passed any Tests on Completion prescribed by the Contract, the Engineer may issue a Taking-Over Certificate in respect of that part of the Permanent works before completion of the whole of the Works and, upon the issue of such Certificate, the Contractor shall be deemed to have undertaken to complete with due expedition any outstanding work in that part of the Permanent Works during the Defects Liability Period.

Surfaces Requiring Reinstatement

Provided that a Taking-Over Certificate given in respect of any Section or part of the Permanent Works before completion of the whole of the Works shall not be deemed to certify completion of any ground or surfaces requiring reinstatement, unless such Taking-Over Certificate shall expressly so state.

56. Taking Over

The Employer shall take over the Site and the Works within seven days of the Engineer or his nominee issuing a certificate of Completion.

Taking-Over Certificate

When the whole of the Works have been substantially completed and have satisfactorily passed any Tests on Completion prescribed by the Contract, the Contractor may give a notice to that effect to the Engineer, with a copy to the Employer, accompanied by a written undertaking to finish with due expedition any outstanding work during the Defects Liability Period. Such notice and undertaking shall be deemed to be a request by the Contractor for the Engineer to issue a Taking-over Certificate in respect of the Works. The Engineer shall, within 21 days of the date of delivery of such notice, either issue to the Contractor, with a copy to the Employer, a Taking- Over Certificate, stating the date on which, in his opinion, the Works were substantially completed in accordance with the Contract, or give instruction in writing to the Contractor specifying all the work which in the Engineer's opinion, is required to be done by the Contractor before the issue of such Certificate. The Engineer shall

also notify the Contractor of any defects in the Works affecting substantial completion that may appear after such instructions and before completion of the Works specified therein. The Contractor shall be entitled to receive such Taking-Over Certificate within 21 days of completion, to the satisfaction of the Engineer, of the Works so specified and remedying any defects so notified.

Taking Over of Sections or Parts

Similarly, in accordance with the procedure set out in above Clause, the Contractor may request and the Engineer shall issue a Taking-Over Certificate in respect of :

- a. any Section in respect of which a separate Time for Completion is provided in the appendix to Tender, or
- b. any substantial part of the Permanent Works which has been both completed to the satisfaction of the Engineer and, otherwise than as provided for in the Contract, occupied or used by the Employer, or
- c. any part of the Permanent Works which the Employer has elected to occupy or use prior to completion (where such prior occupation or use is not provided for in the Contract or has not been agreed by the Contractor as a temporary measure).

57. Final Account

The Contractor shall supply to the Engineer or his nominee a detailed account of the total amount that the Contractor considers payable under the Contract before the end of the Defects Liability Period. The Engineer or his nominee shall issue a Defects Liability Certificate and certify any final payment that is due to the Contractor within 60 days of receiving the Contractor's account if it is correct and complete. If it is not, the Engineer or his nominee shall issue within 15 days a schedule that states the scope of the corrections or additions that are necessary for the correction and certify payment of 50% of the undisputed amount to the contractor. If the Final Account is still unsatisfactory after it has been resubmitted the Engineer or his nominee shall decide on the amount payable to the Contractor and issue a payment certificate, within 60 days of receiving the Contractor's revised account.

58. Submission of 'As built Drawings'

"As built" Drawings are required to be submitted by the Contractor and shall be supplied by them by the dates stated in the Contract Data. If the Contractor does not supply the Drawings and/or manuals by the dates stated in the Contract Data, or they do not receive the Engineer or his nominee's approval, the Engineer or his nominee shall withhold the amount stated in the Contract Data from payments due to the Contractor.

59. Termination

- 59.1 The Employer or the Contractor may terminate the Contract if the other party causes a fundamental breach of the Contract.

59.2 Fundamental breaches of Contract include, but shall not be limited to the following:

- (a) the Contractor stops work for 28 days when no stoppage of work is shown on the current Program and the stoppage has not been authorised by the Engineer or his nominee.
- (b) the Engineer or his nominee instructs the Contractor to delay the progress of the Works and the instruction is not withdrawn within 28 days.
- (c) the Employer or the Contractor becomes bankrupt or goes into liquidation other than for a reconstruction restructure or amalgamation.
- (d) a payment certified by the Engineer or his nominee is not paid by the Employer to the Contractor within 50 days of the date of the Engineer or his nominee's certificate:
- (e) the Engineer or his nominee gives Notice that failure to correct a particular Defect is a fundamental breach of Contract and the Contractor fails to correct it within a reasonable period of time determined by the Engineer or his nominee.
- (f) the Contractor does not maintain a security which is required.
- (g) the Contractor has delayed the completion of works by the number days for which the maximum amount of liquidated damages can be paid as defined in the Contract data and
- (h) if the Contractor, in the judgment of the Employer has engaged in corrupt or fraudulent practices in competing for or in the executing the Contract.

For the purpose of this paragraph: "corrupt practice" means the offering, giving, receiving or soliciting of any thing of value to influence the action of a public official in the procurement process or in contract execution. "Fraudulent practice" means a misrepresentation of facts in order to influence a procurement process or the execution of a contract to the detriment of the Employer, and includes collusive practice. Bidders (prior to or after bid submission) designed to establish bid prices at artificial non-competitive levels and to deprive the Employer of the benefits of free and open competition."

59.3 When either party to the Contract gives notice of a breach of contract to the Engineer or his nominee for a cause other than those listed under Sub Clause 59.2 above, the Engineer or his nominee shall decide whether the breach is fundamental or not.

59.4 Notwithstanding the above, the Employer may terminate the Contract for convenience subject to payment of compensation to the contractor including loss of profit on uncompleted works. Loss of profit shall be calculated on the same basis as adopted for calculation of extra/additional items.

59.5 If the Contract is terminated the Contractor shall stop work immediately, make the Site safe and secure and leave the Site as soon as reasonably possible.

60. Payment upon Termination

- 60.1 If the Contract is terminated because of a fundamental breach of Contract by the Contractor, the Engineer or his nominee shall issue a certificate for the value of the work done less advance payments received up to the date of the issue of the certificate, less other recoveries due in terms of the contract, less taxes due to be deducted at source as per applicable law and less the percentage to apply to the work not completed as indicated in the Contract Data. Additional Liquidated Damages shall not apply. If the total amount due to the Employer exceeds any payment due to the Contractor, the difference shall be a debt payable to the Employer.
- 60.2 If the Contract is terminated at the Employer's convenience or because of a fundamental breach of Contract by the Employer, the Engineer or his nominee shall issue a certificate for the value of the work done, the reasonable cost of removal of Equipment repatriation of the Contractor's personnel employed solely on the Works, and the Contractor's costs of protecting and securing the Works and loss of profit on uncompleted works less advance payments received up to the date of the certificate, less other recoveries due in terms of the contract and less taxes due to be deducted at source as per applicable law.

61. Property

All materials on the Site, Plant, Equipment, Temporary Works and Works for which payment has been made to the contractor by the Employer, are deemed to be the property of the Employer, if the Contract is terminated because of a Contractor's default.

62. Release from Performance

If the Contract is frustrated by the outbreak of war or by other event entirely outside the control of either the Employer or the Contractor, the Engineer or his nominee shall certify that the Contract has been frustrated. The Contractor shall leave the Site and stop work as quickly as possible after receiving this certificate and shall be paid for all work carried out before receiving it and for any work carried out afterwards to which commitment was made.

F. SPECIAL CONDITIONS OF CONTRACT

The conditions of contract shall be the general conditions of contract in Section-III (v) as modified or added by the following condition of special conditions as provided in Section – III(vi) herein, which shall be read and construed with the general condition in Section – 3 A to E as if they were incorporated therein. In so far as any of the condition of the special conditions may conflict or be in consisting with any of general conditions of in Section -3F- Special condition of the contract shall prevail.

63. Labour

The Contractor shall, unless otherwise provided in the Contract, make his own arrangements for the engagement of all staff and labour, local or other, and for their payment, housing, feeding and transport.

The Contractor shall, if required by the Engineer or his nominee, deliver to the Engineer or his nominee a return in detail, in such form and at such intervals as the Engineer or his nominee may prescribe, showing the staff and the numbers of the several classes of labour from time to time employed by the Contractor on the Site and such other information as the Engineer or his nominee may require.

64. Compliance with labour regulations

During continuance of the contract, the Contractor and his sub contractors shall abide at all times by all existing labour enactment and rules made there under, regulations, notifications and bye laws of the State or Central Government or local authority and any other labour law (including rules) regulations, bye laws that may be passed or notification that may be issued under any labour law in future either by the State or Central Government or the local authority. Salient features of some of the major labour laws that are applicable to construction industry are given below. The Contractor shall keep the Employer indemnified in case any action is taken against the Employer by the competent authority on account of contravention of any of the provisions of any Act or rules made there under, regulations or notifications including amendments. If the Employer is caused to pay or reimburse such amounts as may be necessary to cause or observe, or for non-observance of the provisions stipulated in the notifications/bye laws/Acts/Rules/regulations including amendments, if any, on the part of the Contractor the Engineer or his nominee/Employer shall have the right to deduct any money due to the Contractor including his amount of performance security. The Employer / Engineer or his nominee shall also have right to recover from the Contractor any sum required or estimated to be required for making good the loss or damage suffered by the Employer.

The employees of the Contractor and the Sub-Contractor in no case shall be treated as the employees of the Employer at any point of time.

65. Safety, Security and Protection of the Environment.

Subject and without prejudice to any other provision of the Contract, the Contractor shall take all reasonable precautions:

- (a) In connection with underground water resources (including percolating water) to prevent
 - (i) Any interference with the supply to or abstraction from such sources
 - (j) Pollution of the water so as to affect adversely the quality thereof.
- (b) All works shall be carried out without unreasonable noise and disturbance. The Contractor shall indemnify the Employer from and against any liability for damages on account of noise or other disturbance created while or in carrying out the work and from and against all claims, demands, proceedings, damages, costs, charges and expenses whatsoever in regard or in relation to such liability.
- (c) The Contractor at his own cost shall make such provisions for lighting of Works, Temporary Works, Materials and Plant and shall provide all such marks and lights as may be required by the Employer or the Engineer or any other authority having jurisdiction over the Site together with all labour stores and services required for their efficient working and use at any time, day or night.
- (d) The Contractor shall also provide at his own cost every description of watching and maintenance required in connection with the foregoing, and all other services for protecting and securing all places dangerous whether to Contractor's workmen or to other persons until the Works are handed over to the Employer, or till such time when the Engineer decides that such services are no longer required.

All lights provided by the Contractor shall be placed or screened such as not to interfere with any navigation lights or with any traffic or signal lights of any local or other authority.

66. Insurance of Works and Contractor's Equipment

The Insurance shall be issued by Nationalized Insurance Company from its Mangalore Branch which has been determined by the Contractor to be acceptable to the Employer.

The contractor shall at his own costs and expenses obtain and shall cause any subcontractor to obtain such insurance as may be necessary to cover the liability of the contractor or as the case may be of such subcontractor in respect of personal injuries and death arising out of or in the course of or caused during the execution of the works for a minimum amount of Rs. 25 lakhs and shall produce or cause any such subcontractor to produce for inspection the relevant policy or policies together with receipt for the premium paid under such policy/policies as and when required by the Employer.

- i. The Employer (NMPA) shall not be liable for any accident, damage or compensation payable to any workman or other person in the employment of the Contractor or any Subcontractor.

- ii. Employer Liability Insurance: The Contractor shall indemnify and keep indemnified the Employer i.e. NMPA against all damages or compensation payable at Law in respect of or in consequence of any accident or injury to any workman or other person in the employment of the Contractor or Sub-Contractor against all claims, demands, proceedings, costs, charges and expenses whatsoever in respect thereof or in relation thereto and the Employer shall be at liberty to deduct or adjust from the Contractor's bills an amount that Employer may be called upon to pay towards claims, demands, proceedings, costs, charges and expenses whatsoever in respect of or in relation to any accident or injury referred to above without any reference to the Contractor.
- iii. The Contractor shall comply with all the Central State and Municipal Laws and Rules and shall be solely responsible for complying with the provisions of the Contract Labour (Regulations & Abolition) Act, 1970 & the contract labour (Regulation & Abolition) Karnataka Rules 1974 and rules there under and the enactments that may be applicable including ESI Act, the payment of wages act, Provident Fund Act, the Minimum Wages Act, the Factory's Act. The Workmen Compensation Act or any other applicable legislation and the Municipal by-laws or other statutory Rules and Regulations whatsoever in force if these are applicable. Any obligations finding or otherwise missed under any statutory enactments, rules & regulations there under shall be the responsibility of the Contractor and the NMPA will take no responsibility for the same. The Contractor should take Workmen's Compensation Policy for his Workers, who are not covered under ESI and submit the same to the EIC immediately after commencement of the work.
- iv. The Contractor is liable to pay all Statutory Compensation to the Labourers/persons engaged by him for the satisfactory execution of the works. If any claim is made against New Mangalore Port Authority on this work, the Port Authority shall have the right to deduct the same from the bill amount payable to the contractor after verification of the validity and if admissible as per rules.
- v. PERSONAL PROTECTIVE EQUIPMENTS The Contractor shall ensure the use of PPE such as helmets, safety shoes, nose masks, hand gloves, Safety Harness or any other equipment as required depending on nature of work by his staff at site.

67. War Risks Insurance

If the Contractor receives instructions from the Employer to insure against war risks, such insurance if normally available shall be effected, at the cost of the Employer, with the Insurance Company acceptable to the Employer and shall be in the joint names of the Employer and the Contractor.

68. Royalty

Except where otherwise stated, the contractor shall pay to the authority all tonnage and other royalties, rent and other payments or compensation if any, for getting stone, sand, gravel, clay or other materials by him and his subordinates and his subcontractors and required for the works, at the rates and such conditions as notified by the State Government. The applicable rates for royalty is enclosed as Schedule-A in Volume –III. The contractor should submit the Mineral Dispatch Permit (MDP) in

original for the quantity executed by the contractor for the requisite quantity of material incorporated in works for which MDP is issued by the authorized supplier. If contractor fails to submit the MDP in original the amount equal to 5 times the royalty charges shall be deducted from the contractor's bills as per prevailing orders issued by the Authority.

69. Transport of Contractor's Equipment or Temporary Works

If it is found necessary for the Contractor to move one or more loads of heavy constructional plant or equipment materials or pre-constructed units or parts of units of work over roads, highways or bridges on which such oversized and over weight items are not normally allowed to be moved, the Contractor shall obtain prior permission from the concerned authorities. Payments for complying with the requirements, if any, for protection of or strengthening of the roads, highways or bridges shall be deemed to be included in his contract price.

70. Transport of Materials or Plant

The contractor shall save harmless and indemnify the Employer in respect of all claims, proceedings, damages, costs, charges and expenses whatsoever arising out of or in relation to any claim made by the concerned authorities in respect of damage or injury to roads, highways or bridges. In case of failure of the Contractor to settle such claims and in case the Employer is held responsible for payment to the authorities, then the Employer shall settle the claim and the Employer's expenses in this regard, as certified by the Engineer, may be deducted by the Employer from any money due or to become due to the Contractor and the Engineer shall notify the Contractor accordingly with a copy to the Employer.

71. Labor Laws & Regulations

The Contractor shall at all times during the continuance of the Contract comply fully with all existing Acts, regulations and bye-laws including all statutory amendments and re-enactment of State or Central Govt. and other local authorities and any other enactments and act that may be passed in future either by the State or the Central Govt. or local authority, including Indian Workmen's Compensation Act, Contract Labour (Regulation And Abolition) Act 1970 and Equal Remuneration Act 1976, Employees' State Insurance Act, 1948, Factories Act, Minimum Wages Act, Provident Fund Regulations. Employees' Provident Fund Act and schemes made under the same Act, Health and Sanitary Arrangements for Workmen, Insurance and other benefits and shall keep the Employer indemnified in case any action is commenced for contravention by the Contractor. If the Employer is caused to pay or reimburse any amounts as may be necessary to cause or observe, or for non-observance of the provisions stipulated here-forth on the part of the Contractor, the Engineer shall have the right to recover from the Contractor any sum required estimated to be required for

making good the loss or damage suffered by the Employer. The Tenderers must have valid ESI and PF registration and shall maintain the records prescribed under ESI Regulations and PF Act & make the contribution towards ESI and PF in respect of persons employed by the Contractor. The contractor shall make available such records for inspection by ESI and PF authorities during inspection and furnish the copies of such records to the employer regularly. The EPF and ESI contribution on the part of the employer in respect of this contract shall be paid by the contractor. These contributions on the part of Employer paid by the contractor shall be reimbursed by the Engineer –in –charge to the contractor on actual basis. The minimum wages applicable for Mangalore City is enclosed as Schedule – B in Volume – III.

71.1. Accident Prevention/Safety Officer

The Contractor shall have on his staff on site an officer dealing with all matters regarding safety and protection against, accidents of all staff and labour. This officer shall be qualified for this work and shall have the authority to issue instructions and shall take protective measures to prevent accidents.

71.2 Disorderly Conduct

The Contractor shall at all times take all reasonable precautions to prevent any unlawful, riotous or disorderly conduct by or amongst his staff and labour and for the preservation of peace and protection of Persons and property in the neighborhood of the Works from the same.

71.3 Health and Safety

Due precautions shall be taken by the Contractor, and at his own cost, to ensure the safety of his staff and labour and, in collaboration with and to the requirements of the local health authorities, to ensure that medical staff, first aid equipment and stores, sick bay and suitable ambulance services are available at the camps, housing and on the site at all times throughout the period of the Contract and that suitable arrangements are made for the prevention of epidemics and for all necessary welfare and hygiene requirements.

71.4 Supply of Water

The Contractor shall, so far as is reasonably practicable, having regard to local conditions provide on the Site, to the satisfaction of the Engineer's Representative, an adequate supply of drinking and other water for the use of the Contractor's staff and work people.

71.5 Alcoholic Liquor or Drugs

The Contractor shall not, otherwise than in accordance with the Statues, Ordinances and Government Regulations or Orders for the time being in force, import, sell, give, barter or otherwise dispose of any alcoholic liquor, or drugs or permit or suffer any such importation, sale, and gift, barter disposal by his sub-contractions agents or employees.

71.6 Arms and Ammunition

The Contractor shall not give, barter or otherwise dispose of to any persons or person, any arms or ammunition of any kind or permit or suffer the same as aforesaid.

71.7 Festivals and Religious Customs

The Contractor shall in all dealings with labour in his employment have due regard to all recognized festivals, days of rest and religious or other customs.

71.8 Epidemics

In the event of any outbreak of illness of an epidemic nature, the Contractor shall comply with and carry out such regulations, orders and requirements as may be made by the Govt., or the local medical or sanitary authorities for the purpose of dealing with and overcoming the same.

71.9 Employment of Person in the Service of Others

The Contractor shall not recruit or attempt to recruit his staff and labour from amongst persons in the service of the Employer or other agencies engaged for any works of the Employer.

71.10 Housing for Labour

Save in so far as the Contract otherwise provides, the Contractor shall provide and maintain such accommodation and amenities as he may consider necessary for all his staff and labour employed for the purposes of or in connection with the Contract, including all fencing water supply (both for drinking and other purposes), electricity supply, sanitation, cook houses fire prevention and fire-fighting equipment, **crèche for children** of his staff and labour employed for the purposes, furniture, other requirements in connection with such accommodation or amenities. On completion of the Contract, unless otherwise agreed with the Employer, the temporary camps/housing provided by the Contractor shall be removed and the site reinstated to its original condition, all to the approval of the Engineer. The land for construction of labour camps shall be allotted outside the security area to the extent available and such area allotted for labour camps will be charged a ground rent at TAMP approved rates. The ground rent is liable for change as per the prevailing TAMP rates from time to time during the currency of the contract.

71.11 Fair Wages, Records, Inspection

The Contractor shall pay the labourers engaged by him on the work not less than a fair wage which expression shall mean whether for time or piecework the respective rates of wages as fixed by the Public Works Department as fair wages for Dakshina Kannada District payable to the different categories of labourers of those notified under the Minimum Wages Act.

The Contractor shall maintain records of Wages and other remuneration paid to his employee in such form as may be convenient and to the requirements of the Employer/Engineer and the Labour Enforcement Officer (Central), Ministry of Labour, Govt. of India, or such other authorized person appointed by the

Central Govt. The Contractor shall allow inspection of the aforesaid Wage Records and Wage Slips to the Engineer and to any of his workers or to his agent at a convenient time and place after due notice is received, or to any other person authorized by him on his behalf.

71.12 Reporting of Accidents

The Contractor shall report to the Engineer details of any accident as soon as possible after its occurrence. In the case of any fatality or serious accident, the Contractor shall, in addition, notify the local police authorities immediately by the available means.

71.13 Observance by Sub-Contractors

The Contractor shall be responsible for observance by his sub-contractors of the foregoing provisions.

71.14 Port Entry Permission

The Contractor shall submit prior application for Port entry passes to the concerned Port authority for his labours and the staffs engaged in the works. The passes will be issued free of cost.

The Contractor shall retain the original passes obtained by them in respect of their labour and staff engaged in the Works and produce the same to the Engineer as and when called for. It should not be either destroyed or allowed to be taken by the labour/staff after its use.

71.15 Site - Protected Area

The Site of Work is a protected area. Entry to the Port premises is regulated by entry passes. These passes will be issued by the Central Industrial Security Force or any other authority authorized by the Employer. The Contractor should furnish a list of person for whom the passes are to be issued to the Engineer and arrange to obtain the passes from the appropriate authority, based on the recommendation of the Engineer and abide by the Rules of the New Mangalore Port Authority with regard to entry etc. For the entry of trucks and other vehicles also, the Contractor should obtain necessary permits. However, no charges will be levied for the individual passes or the permits for the vehicles of the Contractor or his sub-contractors for the bonafide use of the work.

The Contractor shall retain the original passes obtained by them in respect of their labour and staffs engaged in the Works and produce the same to the Engineer as and when called for. It should not be either destroyed or allowed to be taken by the labour/staff after its use.

72. Life Saving Appliances and First Aid

The Contractor shall provide and maintain upon the Works sufficient proper and efficient life saving appliances and first aid equipment to the approval of the Engineer. The appliances and equipment shall be available for use at all times.

73. Diving Operations (NA)

- a) Any diving work shall be carried out in accordance with the Diving Operations Regulations of the Government of India.
- b) Before any diving work is undertaken the Contractor shall supply the Engineer or his representative with two copies of the Code of signals to be employed and is to have a copy of such Code Prominently displayed on the craft or structure from which the operations take place

74. Bribes

If the Contractor, or any of his Subcontractors, agents or servants gives or offers to give to any person any bribe, gift, gratuity or commission as an inducement or reward for doing or forbearing to do any action in relation to the Contract or any other contract with the Employer, or for showing or forbearing to show favour or disfavor to any person in relation to the Contract or to any other contract with the Employer, then the Employer may enter upon the Site and the works and terminate the employment of the Contractor and the provisions of Clause 63 hereof shall apply as if such entry and termination had been made pursuant to that Clause.

The bidders shall give an undertaking that they have not made any payment or illegal gratification to any person/authority connected with the bid process so as to influence the bid process and have not committed any offence under the PC Act in connection with the bid.

75. Details to be Confidential

The Contractor shall treat the details of the contract as private and confidential, save insofar as may be necessary for the purposes thereof, and shall not publish or disclose the same or any particulars thereof in any trade or technical paper or elsewhere without the previous consent in writing of the employer. If any dispute arises as to the necessity of any publication or disclosure for the purpose of the Contract the same shall be referred to the decision of the Employer whose award shall be final.

76. Contractor's Temporary works, office, etc.

76.1 The Contractor shall submit to the Engineer for his approval not less than 15 days before commencement of erection of any part of Temporary Works, drawings and detailed proposals for the method of construction of Temporary works such as office, store, false work and temporary platforms etc. which he intends to construct for the execution of the contract and no such work shall be constructed before obtaining the written approval of Chief Engineer. These temporary works, office, store etc. shall be erected at or near the work area subject to approval of the Employer and the land space for the same will be allotted free of ground rent to the extent available. The Contractor shall obtain permission for any Temporary Works and would ensure that

during execution of works the statutory requirements of the concerned authorities such as New Mangalore Port Authority, Police, Customs, etc. would be complied with.

76.2 Submission of Reports, Returns, etc.

All reports, statements, returns, drawings, diagrams etc. which the Contractor is required to submit to the Engineer during the progress of the Works, shall be furnished in triplicate without any additional cost.

77. Water Supply

Water to the extent available will be supplied to the Contractor at a fixed point on the main water supply line within the Port area. The plumbing connection and extension of necessary supply pipeline to the working area shall be arranged by the Contractor at his own cost. The Contractor shall also provide a water meter at his cost for metering the quantity of water used. Charges for the consumption of the water will be paid by the Contractor to the Employer at notified rate as applicable time to time during the currency of the Contract. For non-supply of water at any stage port will not be responsible and the Contractor shall not have any claim whatever for loss or damage.

78. Power Supply

The Electricity connection for lighting, welding and other mechanical works to the extent available will be made available by the Employer within the Port area. Drawing of power lines etc. from the available point of supply of power to the actual work site either by overhead lines or underground cables shall be arranged by the contractor at his cost. The temporary lines and connections by the Contractor shall be approved by the Engineer's representative before availing power. The Contractor shall provide Trivector Meter to read consumption in units, power demand and power factor.

The Contractor shall indicate his requirement of power to the Engineer within 15 days from the date of the letter of acceptance of the tender. If the power requirement is more than 50 KW, the Contractor has to avail the power supply at 11 KV and install his own transformer of suitable capacity and work carried out as per IE Rules & Regulations as approved by the CEA. The Contractor shall pay to the Employer, the power charges as per the prevailing Tariff schedule of MESCOM in force during the work of the Contractor. At present, it is Rs.7.46 per unit consumed and demand charges @ Rs. 190.00 per KVA or part thereof per month on connected load, security deposit Rs. 4,604.00 per KVA along with departmental charges @ 23.75% of the bill amount. The Contractor shall also pay the connection and disconnection charges as applicable.

The Contractor shall ensure that the power factor of the system does not fall below 0.90 at any time and shall provide at his cost required capacity capacitors bank to maintain the Power Factor of all power loads. If the capacity of the capacitor found less than stipulated as per regulation during inspection, surcharge at Rs. 0.03 per unit

will be levied. The contractor shall pay refundable Security Deposit of Rs. 4,604/- per KVA of the sanctioned load, before availing the power supply in the form of a Demand Draft drawn in favour of FA&CAO, NMPA from any Scheduled Bank.

The Contractor shall submit a complete drawing of the power points, wiring, diagram indicating all electrical loads, earthing etc. in complete shape along with the completion report. The Trivector Meter provided is calibrated either by M/s. MESCOM or NITK, Surathkal, and such a Certificate to be produced. For non supply of power at any stage port will not be responsible and the Contractor shall not have any claim whatever for loss or damage.

79. Taxes and Duties

79.1 The Contractor shall pay Tax if any and other levies as applicable from time to time. GST at applicable rate shall be shown separate line items in the Tax invoice.

79.2 Sales / Turnover Tax on Works Contract (Deleted)

79.3 Income Tax

The Contractor and his staff shall be responsible for payment of all personal income taxes to the concerned authorities as per the law in force from time to time. Deduction of Income Tax shall be made by the Employer from each certificate of payment to the contractor at the rate of 2% plus surcharge or such other rates as may be specified by the Central Government from time to time, on the gross amount of the Contractor's bill for payment.

79.4 Goods and Service tax

The contractor shall not include GST component in rate. The GST shall be paid to the contractor separately as applicable. The contractor shall submit running account bills indicating GST separately as applicable. The Contractor shall be responsible for the payment of GST applicable, to the GST authority. The contractor shall file the applicable returns with tax department in time and submit the same as documentary evidence.

The invoice with respect to supplies should contain following information:-

- Name of the Customer : New Mangalore Port Authority
- GSTIN of the Customer : 29AAALN0057A2ZG
- All other information as specified in GST act and GST tax invoice rules such as SAC code, Supplier address, Supplier GSTIN, IRN number QR code etc.

Noncompliance of the above result in rejection of invoice.

The Invoice should be uploaded to GST website on monthly basis with in the due date as specified by GST act. Input tax credit lost by Port due to any error, omission or non filing of return will be recovered from any amount due to the supplier Any input tax credit lost by the Port due to due to any error, omission or non filing of return will be recovered from the bills and other monies available with the Port

80. Price Adjustment (not applicable to this contract)**81. Noise and Disturbance**

All works shall be carried out without unreasonable noise and disturbance. The Contractor shall indemnify the Employer from and against any liability for damages on account of noise or other disturbance created while or in carrying out the work and from and against all claims demands proceedings damages costs charges and expenses whatsoever in regard or in relation to such liability.

82. Safety Code

Necessary Indian Safety regulations for the safety purpose shall be adhered to by the contractor and he will be held responsible for any violations of the same. The set of such conditions (regulation) is available with NMPA and the contractor is required to go through it before tendering.

Besides the above, the Contractor shall also scrupulously adhere to and observe the following safety codes:

The Contractor has to provide sufficient barricades to site of work so that traffic plying nearby should not damage the recently concreted work. In case of any damage on account of above, the entire responsibility will remain with contractor and nothing extra will be paid on this account.

Suitable and strong scaffolds should be provided for the workmen for all work that cannot be safely done from ground. No portable single ladder shall be over 8 meters in length.

Hoisting machines and tackles used in the works including their attachments, and supports shall be in perfect condition as per stipulations of the relevant Rules. The ropes used for hoisting or lowering materials or as means or suspension shall be of durable quality and adequate strength and free from defects.

The excavated material shall not be placed within 1.5 meters of the edge of the trench or half of the depth of the trench, whichever is more. All trenches and excavation shall be provided with necessary fencing to lighting. Every opening in the floor of a building or in a working platform shall be provided with suitable fence to prevent the fall of persons or materials. No floor, roof or other parts of the structure shall be so overloaded with debris or materials as to render it unsafe.

Workers employed on mixing and handling materials such as cement, cement mortar, concrete, lime mortar and asphalt shall be provided with protective footwear and rubber hand gloves and thin cloth for covering face and head.

Those engaged in welding work shall be provided with welder protective eye shield and glove.

All safety rules shall be strictly followed while working on live electrical systems or installations as stipulated in the relevant Rules.

83. Port Authority Rules

The Contractor shall observe the Conservancy Rules relating to the harbour and shall always take such necessary additional steps to keep the harbour waters free of noxious or unhygienic matters coming from his works as are required by the Employer. Under no circumstances shall inflammable materials be allowed to spill into the harbour waters.

The Contractor shall always observe and comply with the working rules and regulations of the Port Authority in force or as issued from time to time.

84. Execution of work

The contractor shall be required to execute the work in such a way so as not to cause any damage, hindrance or interference with port activities going on in the area or nearby. He should not also deposit the materials at such places which may cause inconvenience to the public and the work going on in the nearby area. The Contractor shall have to make good all damages done by him to the structures nearby while executing the work and no extra payment shall be made to him on that account.

All the materials required to be used in the work shall have to be got approved from the Engineer-in-Charge before stacking at the site of work.

Barricading, including proper lighting arrangement in the night at the required places shall have to be provided by the contractor at his own cost, including necessary arrangements for proper movement of traffic by carefully maintained approaches and road diversions with suitable sign boards for indications of road signs etc. as directed by the Engineer-in-Charge.

85. Customs Duty

Being Port Development Project, Customs Duty shall be applicable as per project import chapter 9801.00 read with Notification 17-2001, serial No. 38 (vi) and Notification 42-96 amended by 21-2000 of customs tariff, Government of India.

Customs Duty leviable shall be paid directly by the Contractor to the Customs Authorities, Government of India. The Employer shall reimburse this amount upon submission of documentary evidence in original for the proof of payment of such Customs Duty. The reimbursement of such amount towards Customs Duty shall be limited to the Ceiling amount quoted by the Contractor in the Bill of Quantities as above. If the Contractor incurs Customs Duty Levy less than the said Ceiling Amount, the reimbursement by the Employer shall be limited to the documented cost of Customs Duty levies actually paid to the Customs Authorities, Government of India. If the Actual Customs Duty levies paid by the Contractor exceeds the said Ceiling Amount, then the reimbursement by the Employer shall be limited to the Ceiling Amount. The reimbursement of the Customs Duty will be limited only to the Imported Materials listed in "Preamble and Bill of Quantities", BOQ No. ___. During the execution

of the Works, if it necessitates for expeditious completion of the Works, Contractor may resort to import of any of the materials not listed aforesaid, with the approval of the Employer. However, the aggregate amount of Customs Duty to be reimbursed shall not exceed the lump sum amount offered in the Priced Bill of Quantities.

It shall be the responsibility of the Contractor to provide the requisite particulars and documents to the customs and other Government authorities and get the Imported Materials cleared and transported in time. The Contractor shall be fully responsible for port and Customs clearance including stevedoring, handling, unloading, loading, storage, inland transportation, if any of materials, equipments and plant to storage godowns, yards, sites etc. The contractor shall be fully responsible for any delays, penalties charges and losses if any in this regard.

The Employer shall upon request from the Contractor along with necessary details, provide recommendatory letter(s) for Imported Materials at concession rate or Customs Duty as applicable. However, the responsibility for obtaining such concession rate of customs duty shall be that of the Contractor.

It shall be the responsibility of the Contractor to check the latest position on Customs duty levies applicable and the Employer does not accept any liability on the account. For bill of Lading, the "Consignee" for permanent materials to be incorporated into the Works will be the New Mangalore Port Authority. The Contractor will be "Notify Party". Notwithstanding the above, obtaining "Essentiality Certificate" (if any), payment of deposit (if any) towards Customs Duty, etc. shall be the responsibility of the Contractor.

The Contractor shall give an undertaking follows:

- a) Being the ultimate Employer of the materials to be imported and incorporated into the works covered under the Tender _____ we request New Mangalore Port Authority to be consignee in the matter of permanent materials to be imported by us at our cost (covering payments of materials by letter of credit) including freight, insurances, taxes and any other charges whatsoever payable in connection with the import and its incorporation into the work.
- b) We hereby confirm, in the event of New Mangalore Port Authority becoming consignee, it will not absolve us from any of the obligations, and will not alter the payment terms under the Contract No. SCB II/ 2009 dated between (*the Contractor*) and New Mangalore Port Authority.
- c) New Mangalore Port Authority becoming a consignee is a matter of convenience and we undertake to abide by all the obligations, responsibilities etc. as if we are our self a consignee.
- d) In respect of nay consequences arising out of New Mangalore Port Authority becoming the consignee we hereby unequivocally and irrevocably agree to indemnify New Mangalore Port Authority for such consequences.
- e) We also undertake and confirm to obtained all permits and licenses etc. at our own

cost. New Mangalore Port Authority's responsibilities in this regard will be the same as under the said contract and limited to issuing required recommendatory letters for obtaining such permits and licenses.

- f) *This undertaking does not in anyway vitiate our contractual liabilities and obligations cast upon us by Contract No. SCB II/ 2009 dated between(the Contractor) and New Mangalore Port Authority.*

86. Drawings & Designs (Not applicable to this contract)

- (a) General details of the works are shown on the drawings accompanying this tender document. The Engineer will supply to the Contractor from time to time during the progress of the works such further working drawings as will be necessary in his opinion for the proper and adequate execution and maintenance of the Works in accordance with the Engineer's designs and/or any modification thereof as decided by the Engineer and the Contractor shall carry out the work in accordance with the said working drawings. Two sets of such working drawings will be issued. If the Contractor requires more sets he will have to make his own arrangement at his cost. Residual Design, Detailing & Engineering: - The Engineer to the project has done the detailed design and engineering for the subject tender. During execution of the work the residual design, detailing and engineering, if needed, is to be carried out by the contractor at no extra cost to the Employer. For equipment/ Installations detailed drawings need to be produced by the contractor at no extra cost to the Employer. The contractor shall also get approved such design, detailing & engineering from the Engineer.
- (b) In the event of the Contractor proposing any alteration/modification to the Engineer's design, detail, method of construction, he shall at his own expenses prepare and submit for approval of the Engineer copies in duplicate (in the first instance) of detailed working drawings which may be required for such alteration/modification and at the same time call the attention of the Engineer to any alternative detail or modification of the contract drawings which the Contractor may wish to make at least 30 days prior to the commencement of the work or part of the work to which such drawings relate. The contractor shall at the same time, if so required by the Engineer, furnish calculation sheets in duplicate relating to the strength and anticipated deflections in respect of such altered/modified works. The Engineer will, after any such alteration which he may approve, record on the copies as amended his approval and will return one copy of the drawings and calculation sheets to the contractor, who shall carry out the work in accordance therewith. The contractor shall forward to the Engineer three additional copies of the working drawings and calculation sheets as approved in additions to these working drawings and calculation sheets as approved. In addition to these working drawings are also to be submitted (the same procedure as in the case of the contractor) in respect of any work proposed to be executed by sub-contractors.

The approval of the Engineer of all or any of the calculation sheets, drawings shall not relieve the contractor of responsibility in connection with the execution of the altered/modified or subcontractor's work.

(c) Submission of 'As built Drawings'

"As built" Drawings are required to be submitted by the Contractor and shall be supplied by them by the dates stated in the Contract Data. If the Contractor does not supply the Drawings and/or manuals by the dates stated in the Contract Data, or they do not receive the Engineer or his nominee's approval, the Engineer or his nominee shall withhold the amount stated in the Contract Data from payments due to the Contractor.

87. Monsoon Period

Monsoon period will be reckoned from 1st June to 30th September.

88. Progress Report

The following reports shall be submitted for review; as an input to the Management meeting to be held as per Clause No 31 of Conditions of Contract.

88.1 Daily reports

The contractor shall submit daily report indicating daily activities, weather condition, actual manpower, equipment and the prominent materials available and arriving to site. The contractor shall submit the daily report format to the Department for prior approval.

88.2 Monthly Reports

Monthly progress reports shall be prepared by the Contractor and submitted to the Engineer in triplicate. The first report shall cover the period up to the end of the first calendar month following the Commencement Date. Reports shall be submitted monthly thereafter, each within 7 days after the last day of the period to which it relates. Reporting shall continue until the Contractor has completed all work, which is known to be outstanding at the completion date, stated in the Taking-Over Certificate for the Works.

Each report shall include:

- a) Charts and detailed descriptions of progress, including each stage of design (if any), Contractor's Documents, procurement, manufacture, delivery to Site, construction, erection and testing; and including these stages for work by each Sub-Contractor,
- b) Photographs in hardcopy & digital copy and videography in two sets showing the various stages of progress on the Site monthly;
- c) For the supply of manufactured items, the name of the manufacturer, manufacture location, percentage progress, and the actual or expected dates of:
 - i) Commencement of manufacture,
 - ii) Contractor's/Engineer's inspections,

- iii) Tests,
- iv) Shipment and arrival at the Site;
- d) Copies of quality assurance documents, test results and certificates of Materials;
- e) Safety statistics, including details of any hazardous incidents and activities relating to environmental aspects and public relations; and
- f) Comparisons of actual and planned progress, with details of any events or circumstances which may jeopardize the completion In accordance with the Contract, and the measures being (or to be) adopted to overcome delays.

89. Completion Documents (not applicable)

To treat that the work has been completed and issue a final payment certificate, the following documents will be deemed to form the completion documents:

- i) The Technical documents according to which the work was carried out.
- ii) The set of construction drawings showing therein the modifications and corrections made during the course of execution signed by the Engineer.
- iii) Certificates of final levels and dimensions as set out for various works.
- iv) Certificates of tests performed for various works.
- v) "As Built" Drawings.

90. Submission of statutory documents

The successful bidder, with in 7days from the date of work order, shall submit self-attested copy of statutory documents such PAN card, GST registration certificate, Labour Identification Number (LIN) and any other documents required for successful completion of work.

G. SALIENT FEATURES OF SOME MAJOR LAWS APPLICABLE TO ESTABLISHMENTS ENGAGED IN CONSTRUCTION WORK

- (a) Workmen Compensation Act 1923:- The Act provides for compensation in case of injury by accident arising out of and during the course of employment.
- (b) Payment of Gratuity Act 1972: Gratuity is payable to an employee under the Act on satisfaction of certain conditions on separation if an employee has completed 5 years service or more on death at the rate of 15 days wages for every completed year of service. The Act is applicable to all establishments employing 10 or more employees.
- (c) Employees P.F and Miscellaneous Provision Act 1952: The Act Provides for monthly contributions by the employer and workers @ 13.00% and 12% respectively. The benefits payable under the Act are:
 - (i) Pension to family pension on retirement or death, as the case may be.
 - (ii) Deposit linked insurance on the death in harness of the worker.
 - (iii) Payment of P.F accumulation on retirement/death etc.
- (d) Maternity Benefit Act 1951:-The Act provides for leave and some other benefits to workmen/ employees in case of confinement or miscarriage etc.
- (e) Contract Labour (Regulation & Abolition) Act 1970:-The Act provides for certain welfare measures to be provided by the Contractor to contract labour and in case the Contractor fails to provide, the same are required to be provided, by the Principal Employer by Law. The Principal Employer is required to- take Certificate of Registration and the Contractor is required to take license from the designated Officer. The Act is applicable to the establishments or Contractor of Principal Employer if they employ 20 or more contract labor.
- (f) Minimum Wages Act 1948: The Employer is supposed to pay not less than the Minimum Wages fixed by appropriate Government as per provisions of the Act if the employment is a scheduled employment Construction of Buildings, Roads, Runways are scheduled employment.
- (g) Payment of Wages Act 1936:-It lays down as to by what date the wages are to be paid when it will be paid and what deductions can be made from the wages of the workers.
- (h) Equal Remuneration Act 1979:-The Act provides for payment of equal wages for work of equal nature to Male and Female workers and for not making discrimination against Female employees in the matters of transfers, training and promotions etc.
- (i) Payment of Bonus Act 1965: The Act is applicable to all establishments employing 20 or more employees. The Act provides for payments of annual bonus subject to a minimum of 8.33% of wages and maximum of 20% of wages to employees drawing Rs. 3500/- per month or less. The bonus to be paid to employees getting Rs. 2500/- per month or above up to Rs. 3500/- per month shall be worked out by taking wages as Rs. 2500/- per month only. The Act does not apply to certain establishments. The newly set-up establishments are exempted for five years in certain circumstances. Some of the State Governments have reduced the employment size from 20 to 10 for the purpose of applicability of this Act.

- j) Inter-State Migrant workmen's (Regulation of Employment & Conditions of Service) Act 1979: The Act is applicable to an establishment which employs 5 or more inter-state migrant workmen through an intermediary (who has recruited workmen in one state for employment in the establishment situated in another state). The Inter-State migrant workmen, in establishment to which this Act becomes applicable, are required to be provided certain facilities such as housing, medical aid, travelling expenses from home upon the establishment and back,
- k) The Building and Other Construction workers (Regulation of Employment and Conditions of Service) Act 1996 and the Cess Act of 1996: -All the establishments who carry on any building or other construction work and employs 10 or more workers are covered under this Act. All such establishments are required to pay cess at the rate not exceeding 2% of the cost of construction as may be modified by the Government. The Employer of the establishment is required to provide safety measures at the Building or Construction work and other welfare measures, such as Canteens, First-Aid facilities. Ambulance, Housing accommodations for workers near the work place etc. The Employer to whom the Act applies has to obtain a registration certificate from the Registering Officer appointed by the Government.

iv) CONTRACT DATA

Items marked "N/A" do not apply in this Contract.

Sl. No.	Description	Reference Cl. No.
1	The following documents are also part of the Contract	
	The Schedule of other contractors	(8)
	The Schedule of Key personnel	(9)
2	The above insertions should correspond to the information provided in the Invitation of Bids.	
3	The Employer is	(1)
	New Mangalore Port Authority, Panambur, Mangalore – 575010	
	Name of Authorized Representative:	
	Name : The Chairman, New Mangalore Port Authority, Panambur, Mangalore – 575010	
4	The Engineer is	
	Name : Chief Engineer (C), New Mangalore Port Authority, Panambur, Mangalore- 57501010	
	Name of Nominee is	
	Name : Superintending Engineer SE(C-II)Civil Civil Engineering Department, NMPA, Panambur, Mangalore- 575010	
5	The name and identification number of the Contract is	
	Name of Contract :- "Providing M30 grade concrete for Remaining Portion of Berth No. 2 inside wharf area" Tender no: CIVIL/CE©/EE©/54/2024-25	(1)
6	The works consist of "Providing M30 grade concrete for Remaining Portion of Berth No. 2 inside wharf area".	(1)
7	The start date shall be 7 days from the date of Issue of Letter of Acceptance. However, no work shall be commenced without signing contract agreement.	Conditions of contract A-General 1.Definitions

Sl. No.	Description	Reference Cl. No.		
8	The Contract price is the price stated in the letter of acceptance and thereafter as adjusted in accordance with the provisions of the Contract. However, payment will be made as per actual work done accordance with the contract provisions.	1.Definitions		
9	The Intended completion Date for the whole of the Work is 6 (Six) Months Including monsoon with the following milestones:	(17,29)		
10	<p>Milestone dates:</p> <table border="1" data-bbox="359 593 1204 728"> <tr> <td data-bbox="359 593 774 728">Physical works to be completed</td> <td data-bbox="774 593 1204 728">Period from the date of commencement of work</td> </tr> </table> <p>Milestones dates shall be provided to the Contractor by the Executive Engineer executing the work, for completion of the work as per the scheduled date.</p>	Physical works to be completed	Period from the date of commencement of work	
Physical works to be completed	Period from the date of commencement of work			
11	<p>The following shall form part of the Contract Document:</p> <ol style="list-style-type: none"> (1) Form of Agreement (2) Letter of Acceptance (3) Contractor's Bid (4) Contract Data (5) Conditions of Contract including Special Conditions of Contract (6) Specifications (7) Drawings (8) Bill of quantities and (9) Any other documents listed in the Contract Data as forming part of the Contract. (10) Correspondence exchanged after the opening of the Bid and before the issue of Letter of Acceptance by which the Condition of Contract are amended, varied or modified in any way by mutual consent (to be enumerated). 	(2.3)		
12	The Contractor shall submit a Program for the Works within 14 days of delivery of the letter of Acceptance.	(27)		
13	<p>The site possession date</p> <p>The site will be handed over immediately after issue of Letter of acceptance and the site is free from encumbrances. However, no work shall be commenced without signing contract agreement.</p>	(21)		
14	The site is defined in drawing No. 22/164 Location Plan			
15	The Defects Liability Period is 1 (One) year	(35)		

Sl. No.	Description	Reference Cl. No.
16	The minimum insurance cover for physical property, injury and death is Rs. 5,00,000/- (Rupees five Lakhs) per occurrence with the number of occurrences limited to four. After each occurrence, contractor will pay additional premium necessary to make insurance valid for four occurrences always.	13
17	The following events shall also be Compensation Events: The Employer terminates the contract for his convenience.	(44)
18	The period between Programme updates shall be 30 days.	(27)
19	The amount to be withheld for late submission of an updated Programme shall be Rs. 25,000/-.	(27)
20	The Penalty for the delay in submission of the Performance guarantee shall be at the rate of 0.25% of the amount of performance guarantee for each week or part of the week for the number of weeks delayed beyond the stipulated date of submission.	(52.2) 34.1
21	The language of the Contract documents is English.	(3)
22	The law, which applies to the Contract, is the law of Union of India.	(3)
23	The currency of the Contract is Indian Rupees.	(46)
24	Fees and types of reimbursable expenses to be paid to the Dispute Review Board (Deleted) As per actuals and equally shared by both the parties. (NA)	(25)
25	The Dispute Review Board shall be constituted after signing of the agreement on mutually agreed terms. (Appendix 1). (Deleted) (NA)	(25)
26	Price Adjustment (deleted)	(47) (80)
27	The proportion of payments retained (retention money) shall be 10% of total tax invoice value from each bill subject to a maximum of 5% of the contract price including GST as applicable.	(48)
28	The maximum amount of liquidated damages for the whole of the works is 10 % of the contract price plus taxes and duties. The half per cent (½%) per week L.D is applicable for delay period of $\frac{1}{3}$ of contract period and thereafter 10% L.D is applicable.	[49]
29	Clause No. 49A (v) deleted.	
30	Advance payment is not applicable to this contract	[51]
31	Repayment of secured advance: deleted	(51.6)

Sl. No.	Description	Reference Cl. No.
32	The Securities shall be for the following minimum amounts equivalent as a percentage of the Contract Price.	(52)
33	Performance Security in the form in the form of Insurance Surety Bonds, Account Payee Demand draft, Fixed Deposit Receipt from a commercial bank, remittance by RTGS or in the form of Bank Guarantee for 5% of the contract price inclusive of GST.	(52.2)
34	The standard form of Performance Security acceptable to the Employer shall be an unconditional Bank Guarantee of the type as presented in Section III (iv) of the Bidding Documents.	Annexure-A
35	The Contractor has to submit the final claim for reimbursement of ESI and EPF contribution on the part of the employer in respect of this contract within 60 days from the date of completion of work.	(71)

v) FORM OF SECURITIES

Acceptable forms of securities are annexed. Bidders should not complete the Performance Security form at this time. Only the successful Bidder will be required to provide Performance and Advance Payment Securities in accordance with one of the forms, or in a similar form acceptable to the Employer.

Annexure A: Performance Bank Guarantee

Annexure B: Bank Guarantee for Advance Payment (not applicable to this contract)

Annexure A

PERFORMANCE BANK GUARANTEE

To: _____ [name of Employer]
 _____ [address of Employer]

WHEREAS _____ [name and address of Contractor]
 (hereinafter called "the Contractor") has undertaken, in pursuance of Contract
 _____ No. _____ dated _____ to execute
 _____ [name of Contract and brief
 description of Works] (hereinafter called "the Contract").

AND WHEREAS it has been stipulated by you in the said Contract that the Contractor shall
 furnish you with a Bank Guarantee by a recognized bank for the sum specified therein as
 security for compliance with his obligations in accordance with the Contract;

AND WHEREAS we have agreed to give the Contractor such a Bank Guarantee;

NOW THEREFORE we hereby affirm that we are the Guarantor and responsible to you, on
 behalf of the Contractor, up to a total of
 _____ [amount of guarantee]¹

_____ [In words], such sum being payable in the
 types and proportions of currencies in which the Contract Price is payable, and we undertake
 to pay you, upon your first written demand, and without cavil or argument, any sum or sums
 within the limits of _____ [amount of guarantee]¹ as
 aforesaid without your needing to prove or to show grounds or reasons for your demand for
 the sum specified therein.

We hereby waive the necessity of your demanding the said debt from the Contractor before
 presenting us with the demand.

We further agree that no change or addition to or other modification of the terms of the
 Contract or of the Works to be performed there under or of any of the Contract documents
 which may be made between you and the Contractor shall in any way release us from any
 liability under this guarantee, and we hereby waive notice of any such change, addition or
 modification.

This guarantee shall be valid until 28 days from the date of expiry of the Defects Liability
 Period.

Notwithstanding anything mentioned above,

Our liability against this guarantee is restricted to Rs..... (Rupees
 only) and unless a claim in writing is lodged with us within 3 months of the
 date of expiry or the extended date of expiry of this guarantee all our liabilities under this
 guarantee shall stand discharges.

IN WITNESS WHEREOF this guarantee has been duly executed on this day of

Signature and seal of the guarantor _____

Name of Bank _____

Address _____ Date _____

1 An amount shall be inserted by the Guarantor, representing the percentage of the Contract Price specified in the Contract and denominated in Indian Rupees.

Annexure B (NA)**BANK GUARANTEE FOR ADVANCE PAYMENT (NOT APPLICABLE)**

To: _____ [name of Employer]
 _____ [address of Employer]
 _____ [name of Contract]

Gentlemen:

In accordance with the provisions of the Conditions of Contract, Sub-clause 51.1 ("Advance Payment") of the above mentioned Contract, _____ [name and address of Contractor] (hereinafter called "the Contractor") shall deposit with _____ [name of Employer] a bank guarantee to guarantee his proper and faithful performance under the said Clause of the Contract in an amount of

1

_____ [amount of guarantee] _____ [in words].

We, the _____ [bank or financial institution], as instructed by the Contractor, agree unconditionally and irrevocably to guarantee as primary obligator and not as Surety merely, the payment to _____ [name of Employer] on his first demand without whatsoever right of objection on our part and without his first claim to the Contractor, in the amount not exceeding _____ [amount of guarantee]1 _____ [in words].

We further agree that no change or addition to or other modification of the terms of the Contract or of Works to be performed there under or of any of the Contract documents which may be made between _____ [name of Employer] and the Contractor, shall in any way release us from any liability under this guarantee, and we hereby waive notice of any such change, addition or modification.

The guarantee shall remain valid and in full effect from the date of the advance payment under the Contract until _____ [name of Employer] receives full repayment of the same amount from the Contractor.

Notwithstanding anything mentioned above,

Our liability against this guarantee is restricted to Rs.....(Rupeesonly) and unless a claim in writing is lodged with us within 3 months of the date of expiry or the extended date of expiry of this guarantee all our liabilities under this guarantee shall stand discharges.

IN WITNESS WHEREOF this guarantee has been duly executed on thisday of

Yours truly,

Signature and seal: _____

Name of Bank/Financial Institution: _____

Address: _____

Date: _____ 1. An amount shall be inserted by the bank or financial institution representing the amount of the Advance Payment, and denominated in Indian Rupees.

Annexure – C (NA)**BANK GUARANTEE FOR RETENTION MONEY (NOT APPLICABLE)**

To
 New Mangalore Port Authority,
 Administrative Building,
 Panambur,
 Mangalore – 575 010.

1. In consideration of the Board Members of the New Mangalore Port Authority, Mangalore (hereinafter called "The Board" having agreed to refund _____ (hereinafter called "the said contractor(s)") under the terms and conditions of an Agreement No. _____ made between New Mangalore Port Authority and _____ (hereinafter called "the said Agreement") the retention money for the due fulfillment by the said contractor(s) of the terms and conditions contained in the said agreement on production of a bank guarantee for _____. We _____ (hereinafter referred to as "the Bank") at the request of M/s. _____ do hereby undertake to pay the Board an amount not exceeding _____ on demand.
2. We _____ do hereby undertake to pay the amounts due and payable under this guarantee without any demur, merely on a demand from the Board stating that the amount claimed is required to meet the recoveries due or likely to be due from the said Contractor(s). Any such demand made on the bank shall be conclusive as regards the amount due and payable by the Bank under this guarantee. However, our liability under this guarantee shall be restricted to an amount not exceeding Rs. _____
3. We _____ undertake to pay the Board any money so demanded notwithstanding any dispute or disputes raised by the Contractor(s) in any suit or proceeding pending before any Court or Tribunal relating there to, our liability under this present being absolute and unequivocal.
 The payment so made by us under this bond shall be a valid discharge of our liability for payment there under and the Contractor(s) shall have no claim against us for making such payment.
4. We _____ further agree that the guarantee herein contained shall remain in full force and effect during the period that would be taken for the performance of the said Agreement and that it shall continue to be enforceable till all the dues of the

Board under or by virtue of the said Agreement have been fully paid and its claims satisfied or discharged or till Engineer-in-charge on behalf of the Board certifies that the terms and conditions of the said Agreement have been fully and properly carried out by the said Contractor(s) and accordingly discharges this guarantee.

5. We _____ further agree with the Board that Board shall have the fullest liberty without our consent and without affecting in any manner our obligations here under to vary any of the terms and conditions of the said agreement or to extend time of performance by the said Contractor(s) from time to time or to postpone for any time or from time to time any of the powers exercisable by the Board against the said Contractor(s) and to forbear or enforce any of the terms and conditions relating to the said Agreement and we shall not be relieved from our liability by reason of any such variation, or extension being granted to the said Contractor(s) or for any forbearance act or omission on the part of the Board or any indulgence by the Board to the said Contractor(s) or by any such matter or thing whatsoever which under the law relating to sureties would but for this provision, have effect so relieving us.
6. This guarantee will not be discharged due to the change in the constitution of the Bank or the Contractor(s).
7. We _____ lastly undertake not to revoke this guarantee except with the previous consent of the Board in writing.
8. This guarantee shall be valid up to _____ unless extended on demand by Board Notwithstanding anything mentioned above, our liability against this guarantee is restricted to Rs. _____ and unless a claim in writing is lodged with us within three months of the date of expiry or such extended date of expiry of this guarantee all our liabilities under this guarantee shall stand discharged.

Notwithstanding anything contained herein.

1. Our liability under this Bank Guarantee restricted to a sum of Rs. _____
_____ Only).
2. This bank guarantee shall be valid up to _____ We are liable to pay the guaranteed amount or any part thereof under this bank guarantee only and only if you serve upon us a written claim or demand on or before _____.

APPENDIX 1 TO GENERAL CONDITIONS OF CONTRACT (NA)

DISPUTES REVIEW BOARD AGREEMENT (NOT APPLICABLE)

THIS AGREEMENT, made and entered into this Day
of.....20..... Between (“the Employer”)
and.....
..... (“the Contractor”), and the Disputes Review Board (“the Board”)
consisting of One / three Board Members, (1)
..... (2)
..... (3)

[Note : Delete whatever is not applicable]

WITNESSETH, that

WHEREAS, the Employer and the Contractor have contracted for the construction of the
.....

..... (Project name)
..... (the “Contract”) and

WHEREAS, the contract provides for the establishment and operation of the Board NOW
THEREFORE, the parties hereto agree as follows :

1. The parties agree to the establishment and operation of the Board in accordance with this Board Agreement.
2. Except for providing the services required hereunder, the Board Members should not give any advice to either party or to the Engineer or his nominee concerning conduct of the Works.

The Board Members :

- a. shall have no financial interest in any party to the contract or the Engineer or his nominee, or a financial interest in the contract, except for payment for services on the Board.
- b. shall have had no previous employment by, or financial ties to, any party to the contract, or the Engineer or his nominee, except for fee based consulting services on other projects, all of which must be disclosed prior to appointment to the Board.
- c. shall have disclosed in writing to the parties prior to signature of this Agreement any and all recent or close professional or personal or personal relationships with any director, officer, or employee of any party to the contract, or the Engineer or his nominee, and any and all prior involvement in the project to which the contract relates;
- d. shall not, while a Board Member, be employed whether as a consultant or otherwise

by either party to the contract, or the Engineer or his nominee, except as a Board Member.

- e. shall not, while a Board Member, engage in discussion or make any agreement with any party to the contract, or with the Engineer or his nominee, regarding employment whether as a consultant or otherwise either after the contract is completed or after services as a Board Member is completed;
 - f. shall be and remain impartial and independent of the parties and shall disclose in writing to the Employer, the Contractor, the Engineer or his nominee, and one another any fact or circumstances which might be such to cause either the Employer or the Contractor to question the continued existence of the impartiality and independence required of Board Members.
3. Except for its participation in the Board's activities as provided in the contract and in this Agreement none of the Employer, the Contractor, the Engineer or his nominee, and one another any fact or circumstances which might be such to cause either the Employer or the Contractor to question the continued existence of the impartiality and independence required of Board Members.
 4. The Contractor shall :
 - a) furnish to each Board Members one copy of all documents which the Board may request including contract documents, progress reports, variation orders, and other documents, pertinent to the performance of the Contract.
 - b) in co-operation with the Employer, co-ordinate the Site visits of the Board, including conference facilities, and secretarial and copying services.
 5. The Board shall serve throughout the operation of the contract. It shall begin operation following execution of this Agreement, and shall terminate its activities after issuance of the taking over Certificate and the Board's issuance of its Recommendations on all disputes referred to it.
 6. Board Member shall not assign or subcontract any of their work under this Agreement.
 7. The Board Members are independent and not employees or agents of either the Employer or the Contractor.
 8. The Board Members are absolved of any personal or professional liability arising from the activities and the Recommendations of the Board.
 9. Fees and expenses of the Board Member[s] shall be agreed to and shared equally by the Employer and the Contractor. If the Board requires special services, such as accounting, data research, and the like, both parties must agree and the costs shall be shared by them as mutually agreed.
 10. Board Site visits :
 - a. The Board shall visit the Site and meet with representatives of the Employer and the Contractor and the Engineer or his nominee at regular intervals, at times of critical construction events, and at the written request of either party. The timing of Site failing agreement shall be fixed by the Board.
 - b. Site meetings shall consist of an informal discussion of the status of the construction

of the works followed by an inspection of the works, both attended by personnel from the Employer, the Contractor and the Engineer or his nominee.

- c. If requested by either party or the Board, the Employer will prepare minutes of the meetings and circulate them for comments of the parties and the Engineer or his nominee.

11. Procedure for disputes referred to the Board:

- a. If either party objects to any action or inaction of the other party or the Engineer or his nominee, the objecting party may file a written Notice of Dispute to the other party with a copy to the Engineer or his nominee stating that it is given pursuant to Clause 65 and stating clearly and in detail the basis of the dispute.
- b. The party receiving the Notice of Dispute will consider it and respond in writing within 7 days after receipt.
- c. This response shall be final and conclusive on the subject, unless a written appeal to the response is filed with the responding party within 7 days of receiving the response. Both parties are encouraged to pursue the matter further to attempt to settle the dispute. When it appears that the dispute cannot be resolved without the assistance of the Board either party may refer the dispute to the Board by written Request for Recommendation to the Board, the other party and the Engineer or his nominee stating that it is made pursuant to Clause 65.
- d. The Request for recommendation shall state clearly and in full detail the specific issues of the dispute to be considered by the Board.
- e. When a dispute is referred to the Board, and the Board is satisfied that the dispute requires the Board's assistance, the Board shall decide when to conduct a hearing on the dispute. The Board may request that written documentation and arguments from both parties be submitted to each Board Members before the hearing begins. The parties shall submit insofar as possible agreed statements of the relevant facts.
- f. During the hearing, the Contractor, the Employer, and the Engineer or his nominee shall each have ample opportunity to be heard and to offer evidence. The Board's Recommendations for resolution of the dispute will be given in writing, to the Employer, the Contractor and the Engineer or his nominee as soon as possible, and in any event not more than 28 days after the Board's final hearing on the dispute.

12. Conduct of Hearings :

- a. Normally hearing will be conducted at the Site, but any location that would be more convenient and still provide all required facilities and access to necessary documentation may be utilised by the Board. Private sessions of the Board may be held at any location convenient to the Board.
- b. The Employer, the Engineer or his nominee and the Contractor shall have representatives at all hearings.
- c. During the hearings, no Board Member shall express any opinion concerning the

merit of any facet of the case.

- d. After the hearing are concluded, the Board shall meet privately to formulate its Recommendations. All Board deliberations shall be conducted in private, with all individual views kept strictly confidential. The Board's Recommendations, together with an explanation of its reasoning shall be submitted in writing to both parties and to the Engineer or his nominee. The Recommendations shall be based on the pertinent contract provisions, applicable laws and regulations, and the facts and circumstances involved in the dispute.
- e. The Board shall make every effort to reach a unanimous Recommendation. If this proves impossible, the majority shall decide, and the dissenting member any prepare a written minority report for submission to both parties.

[Note : Delete if it is one member Board]

13. If during the contract period, the Employer and the Contractor are of the opinion that the Dispute Review Board is not performing its functions properly; the Employer and the Contractor may together disband the Disputes Review Board. In such an event, the disputes shall referred to Arbitration straightaway.

The Employer and the Contractor shall jointly sign a notice specifying that the Board shall stand disbanded with effect from the date specified in the notice. The notice shall be posted by a registered letter with AD or delivery of the letter, even if he refuses to do so.



**NEW MANGALORE PORT AUTHORITY
PANAMBUR, MANGALORE**

**“Providing M30 grade concrete for Remaining Portion of Berth No.
2 inside wharf area”**

**TENDER DOCUMENT
Volume – II**

NEW MANGALORE PORT AUTHORITY

CIVIL ENGINEERING DEPARTMENT

Tender no: CIVIL/CE(C)/EE(C)/54/2024-25

Tender for

“Providing M30 grade concrete for Remaining Portion of Berth No. 2 inside wharf area”

<u>Volume I</u>	Section I	i) Notice Inviting Tenders i) Instructions to Tenderers ii) Annexure (1 to 14)
	Section II	i) Form of Agreement
	Section III	i) Conditions of Contract: Part A - E: General Conditions ii) Conditions of Contract : Part F: Special Conditions iii) Contract Data iv) Form of Securities (A & B) v) Appendix – I and Appendix - II
<u>Volume II</u>	Section IV	i) Technical Specifications
	Section V	ii) Drawings
<u>Volume III</u>	Section VI	i) Preamble ii) Bill of Quantities iii) For of tender
	Section VII	i) Schedules (A & B)

Table of Contents

SECTION IV	113
TECHNICAL SPECIFICATIONS.....	113
A. GENERAL.....	113
1. INTRODUCTION	113
TECHNICAL SPECIFICATIONS	116
B. WORKS	116
MATERIALS.....	116
C. WORKMANSHIP	Error! Bookmark not defined.
General	Error! Bookmark not defined.
1. SHIFTING OF DRAWFT WALL.....	127
2. 4.5 SPECIFICATIONS FOR READY MIXED CONCRETE	127
3. SPECIFICATIONS FOR STEEL FOR CONCRETE REINFORCEMENT	183
SECTION V	193
DRAWINGS	193

SECTION IV**TECHNICAL SPECIFICATIONS****A. GENERAL****1. INTRODUCTION**

The intent of this technical specification covers construction of all civil works as covered in the scope of contract as per drawings supplied by Owner.

All civil works shall be carried out as per design / drawings standardized by the Consultant / Owner and the specification provided by the Consultant / Owner. All standard drawings are enclosed with the tender documents. In case any item is not covered under specification then the same shall be carried out as per CPWD specification and applicable Standards and Codes. Any item for which specification is not provided herein and is not covered under CPWD specification shall be executed as per manufacturer guidelines. All materials shall be of best quality conforming to relevant Standards and Codes. In case of any conflict between Standards / Code and Technical Specification, the provisions of Technical Specification shall prevail, and the Engineer's decision on interpretation shall be final.

The Contractor shall furnish all labor, tools, equipment, materials, temporary works, constructional plant and machinery, fuel supply, transportation and all other incidental items not shown or specified but as may be required for complete performance of the Works in accordance with drawings, specifications and direction of Owner.

Excavated earth is to be disposed from site as instructed, only into approved landfill areas and dump yard. The cost of excavation to include for necessary lead and lift as specified.

All materials including cement, reinforcement steel and structural steel etc. shall be arranged by the Contractor. All testing required shall be arranged by the Contractor at his own cost. The contractor shall execute the work as per the standard Field Quality Plan (FQP) of NMPA.

The bidder shall fully apprise himself of the prevailing conditions at the proposed site, climatic conditions including monsoon patterns, local conditions and site specific parameters and shall include for all such conditions and contingent measures in the bid, including those which may not have been specifically brought out in the specifications.

Level and date of concreting shall be marked on the building from outside at every floor level with proper paint, etc.

All levels and survey work shall be measured by total station and electronic level machine at all floors and places.

Brief Description of Works

The scope of work is defined in the Notice Inviting Tender. The Contractor shall provide all necessary materials, equipment and labour etc. for the execution and maintenance of the work till completion.

The work shall be executed in accordance with the specification stipulated in the Bill of Quantity and other bidding documents read along with CPWD (Central Public Works Department) specifications for civil works and IS codes with up-to-date revisions. For non-schedule items specification as given along with tender document and similar items of CPWD shall be applicable.

The list of references for civil works are CPWD specifications, relevant IS codes and best practices.

For deep excavations, necessary shoring is to be done, the design of which will be provided by the contractor, after assessing site and soil conditions, and work only to be commenced on site after the same is duly approved by NMPA. Any approval if required from the Mineral department or any other statutory body that has jurisdiction on such excavations has to be obtained by the contractor.

All earth used for back filling should be of approved quality.

For ready mixed cement concrete, in addition to the CPWD specification, the following also to be noted:

The cost towards cement quantity reduced from the specified quantity in the item due to mixing of fly ash shall be deducted as per relevant BOQ item. The design mix shall be submitted to Engineer in Charge for approval.

All hard ware fittings shall be of best quality and shall be selected as per the Instructions of Engineer in Charge.

Site location, Boundaries and Possession

The location and boundaries of the Site are shown on the Drawing No. **22/164-LP** The Contractor shall confine his activities strictly to the allotted site area(s) and shall not allow his personnel to trespass upon any other areas occupied by the Employer.

1.4 Site Datum and Base Lines

A base line shall be established within the working area by the Contractor. The base line shall be referenced to the site co-ordinate system (based on the Local Coordinates of New Mangalore Port). This bench mark and base line will be the basis for the setting-out for all the Works. The main levels and lines for each portion of the Works shall be established from the bench mark and base line by the Contractor.

1.5 Site Conditions

1.5.1 Location of Work (As per Drawing)

1.5.2 Climate

The climate at Mangalore is tropical with high humidity and a maximum shade temperature of 36°C. The average annual rainfall is approximately 3330 mm and concentrated in the south-west monsoon months of June, July, August and September during which period the average rainfall is as much as 82% of the total annual rainfall.

1.5.3 Wind

The wind in the monsoon months of June, July and August, September are predominantly from south-west and west with a maximum intensity of 5 on the Beaufort Scale. The winds in the remaining months of the year are predominantly from the north-west and the maximum intensity during this period is also of 5 on the Beaufort Scale.

1.5.4 Cyclones

Even though Mangalore is within the cyclonic area of storms originating in the Arabian Sea and those that enter across the Indian Peninsula from Bay of Bengal, cyclones are not as severe or frequent as in the Bay of Bengal. The maximum wind speed so far recorded in cyclonic storm, generally does not exceed 62 kmph (16.9 m/sec.) except one during 1965 when the maximum speed recorded was 97 kmph (26.9 m/sec.)

1.5.5 Visibility

Thirty-year period observations conducted by the Indian Meteorological Department reveal that poor visibility (visibility less than 4 Kms) is encountered for about 10 days in the south-west monsoon period. The maximum number of foggy days in a year is only 3.

1.5.6 Site Preparation

The Contractor shall furnish all necessary supervision, labour, materials, equipment and tools for Site Preparation, clearing and all other works. Clearing shall mean to completely demolish, remove and dispose with all leads, lifts and descents from the area marked, trees, bushes, deadfalls, embedded logs, dislodged roots, stumps, snogs, boulders, mounds, existing structures and other objectionable materials. The areas required to be cleared shall consist of the work Site, ditches, borrow pits, diversions and all other areas necessary for the construction work as directed by the Engineer-in-Charge.

Before any Temporary Works are commenced, the Contractor shall submit his proposal along with complete drawings of all Temporary Work, he may require for the execution of the Works in advance to the Engineer for approval. The Contractor shall also submit his calculations relating to the design of temporary works, strength, etc. if required by the Engineer and shall carry out the modifications that the Engineer may require of such temporary works at Contractor's own cost. The Contractor shall be solely responsible for the stability and safety of all Temporary Work.

It will be the responsibility of the Contractor to make timely procurement of all materials and mobilize all essential equipment for both Temporary and Permanent Works.

1.6 Site Information

The reference is invited to detailed drawing of the construction site for adaptation of methodology for the construction of foundation. However, on account of this change in the geographical profile of site, no extra cost for additional arrangement required to be made will be paid for.

1.7 The Nature of Soil Profile & Pile Depth

The details furnished herein are only for the information/guidelines of the tenderers and the successful contractor shall not claim for any deviation in the actual subsoil profile encountered at site.

1.8 Records

Complete records of all operations connected with the work shall be kept by the Contractor. The Contractor shall submit to the Engineer-in-charge for approval his proposal of the manner of presentation of these records. Three copies of all such records shall be furnished to the Engineer-in-charge on completion of each test or operation.

TECHNICAL SPECIFICATIONS

A. WORKS

MATERIALS

1.2.1 Quality of material

All materials used in the work shall be of the best quality of their respective kinds as specified herein, obtained from sources and suppliers approved by the Engineer-in-charge and shall comply strictly with the tests prescribed hereinafter, or where tests are not laid down in the specification, with the requirements of the latest issues of the relevant Indian Standard codes. Any material not fully specified herein and for which there is no relevant Indian Standard, shall be the best of their kind and to the approval of the Engineer-in-charge.

All manufactured articles unless otherwise allowed by the Engineer in charge shall bear ISI mark and shall be obtained from Manufacturers directly or from recognized dealers of manufacturers.

All material used in the work shall be subjected to inspection and test. Samples of all materials proposed to be employed in the permanent works shall be submitted to the Engineer-in-charge for approval, before they are brought to site. Material may be rejected if found not suitable or in accordance with the specifications notwithstanding the results of tests at the manufacturer's works or elsewhere or test certificates or any approval given earlier.

Materials used in the works shall be stored on stacks, supports, in bins, under cover, etc., as per IS 4082 as appropriate to prevent deterioration or damage from any cause whatsoever to the entire satisfaction of the Engineer-in-charge and as stated in the succeeding clauses.

1.2.2 Procurement of Cement

The contractor shall procure all the cement of approved quality required for the work from the open market.

1.2.3 Tests after delivery to site

At the discretion of the Engineer-in-charge cement shall, after delivery to site, be subjected to all the tests and analysis required by the relevant Indian standards. Samples shall be collected as directed by the Engineer-in-charge and tests carried out at an approved laboratory / site laboratory. The cement from which the samples have been extracted shall not be in used in any works before completion of the testing and analysis and until it has been accepted as satisfactory by the Engineer-in-charges. However the use of cement will be allowed after satisfactory results of 3 days and 7 days. In addition to the above tests and analysis, the Engineer-in-charge may order further tests on the cement after it has been stored at the site prior to use, in order to determine if the cement has deteriorated during storage. No cement shall be allowed to be used until it has been accepted as satisfactory by the Engineer-in-charge.

The costs of all the tests on cement are deemed to be included in the rates and prices and shall not be paid extra.

1.2.4 Sampling and Testing

All materials used in the work shall be subjected to inspection and test. Samples of all materials proposed to be employed in the permanent works shall be submitted to the Engineer-in-charge for approval, before they are brought to site. All the materials shall be in accordance with the

specification. Where materials are specified to comply with I.S., the contractor shall furnish manufacture's certificate that the materials satisfy the requirement of IS specifications.

Material may be rejected if found not suitable or in accordance with the specifications notwithstanding the results of tests at the manufacturer's works or elsewhere or test certificates or any approval given earlier.

Expenditure towards samples and tests whether at the manufacturer's premises at source, at site or at any testing laboratory or institution as directed by the Engineer-in-charge shall be deemed included in the rates quoted in the Bill of Quantities and no extra payment whatsoever shall be made on this account. All the material testing equipment's have to be calibrated and calibration reports for all the equipment's are to be produced.

Even though it is obligatory duty of the contractor to have an up to date laboratory at site and testing equipment's are required to carry out the necessary tests in presence of Engineer's representative they shall arrange to test any of the materials / concrete cubes etc or in outside laboratories of Engineer's choice. All cost i.e. cost of testing, cost of material, packaging, transportation etc. to be borne by the contractor. In case, the Contractor proposed to use ready mix concrete, the facilities for testing of materials and laboratory tests of ready mix concrete, shall be available at mixing plant.

The following are the tests to be carried out for various materials used for construction at frequencies as stated below:

Table

Sl. No.	Material	Tests	Control criteria	Frequency
1	Concrete:			
	Cement	Consistency	IS 4031 – Part 4	1 Test per each consignment.
		Initial setting time	IS 4031- Part 5	
		Final setting Time		
		Soundness	IS 4031- Part 3	
		Finess		
		Compressive strength in N / mm ²	IS 4031 – Part 6	
	Gradation	Coarse aggregate	IS 383- 1970	As per design and one test per 50m ³ ,
		Fine aggregate	IS 2386 – Part 1	As required.
		Water absorption	IS 2386 – Part 3	1 test per source
		Soundness test	IS 2386 – Part 5	1 test per 50m ³
		Aggregate Impact value / Los Angeles Abrasion value	IS 2386 – Part 4	1 test per 50m ³
		Flakiness	IS 2386 – Part I	1 test per 50m ³
		Bulkage and silt content	IS 2386 – Part 2 & 3	1 test per source

2	M- 30 Grade Concrete			
	Workability and Slump		IS 1199	As per design requirement and 1 test per each transit mixer / dumper
	Strength of Concrete	As per design requirement	IS 516	1 to 5 M3 = 6 cubes 6 to 15 M3 = 9 cubes 16 to 30 M3 = 12 cubes 31 to 50 M3 = 15 cubes > 50 m3 = 15 + 3 cubes for every 50 M3
3.	Water	Chemical Test	IS: 456	Once for every change of source and as required.
4.	Reinforcement bars	Mechanical Test and Chemical Test (TMT bars)	IS: 432 & IS: 1786	For each Consignment of different dia of reinforcement bars received.

In case Contractor proposes to use Ready Mix Concrete, the above frequency should be followed at mixing plant.

1.2.5 Storage

The Contractor shall make adequate arrangements to deliver and store sufficient quantity of all the materials required for the work at his own cost.

Tools, Equipment and Appliances

All tools equipment and appliances for the proper execution of all works and operation like batching, mixing, placing, finishing and curing of the concrete and other items shall be on the project in good working condition and all have been inspected by the Engineer in charge before the works are permitted to start. Throughout the construction of the project, the Contractor shall maintain adequate equipment in first class working condition to ensure proper execution of the work.

Specification for controlled concrete

All concrete shall comply with the requirements of I.S. 456. Wherever a reference is made to any Indian standard code of practice it shall mean the latest version of the relevant standard in use.

Concrete work shall be supervised by a competent concrete technologist approved by the Engineer in charge, whose duty will be to supervise all stages of designing the mix, preparation and placing of concrete. All cubes shall be made and site tests carried out under his direct supervision in the presence of Engineer in charge his recognized representatives. In order to exercise the required degree of constant control over the concrete materials and their preparations, the contractor shall set up and maintain at his own expense a testing laboratory at site. He shall provide all apparatus required for sensitive testing of concrete and concrete materials as stated in Clause 8.2 If the Contractor proposes to use ready mix concrete, the control shall be exercised at mixing plant.

Before the commencement of construction work, the Contractor shall supply to the Engineer in charge for his approval drawings showing the general detailed arrangement for concreting plant.

All materials which have been damaged, contaminated or have deteriorated or do not comply in any way with the requirements of this specifications shall be rejected and shall be removed from the site at the contractors expense.

Materials viz. Cement, fine aggregates, coarse aggregates, water etc. shall be tested, if directed, in an approved testing laboratory and test reports in original, shall be forwarded to Engineer in charge and all costs of tests shall be borne by the Contractor.

The concrete mix shall be designed by any of the recognized and accepted methods. The proportions chosen should be such that the concrete is of adequate workability for the conditions prevailing on the work in quality and can be properly compacted.

Except where it can be shown to the satisfaction of the Engineer in charge that supply of properly graded aggregate of uniform quality can be maintained over the period of work, the grading of aggregate should be controlled by obtaining the coarse aggregate in different sizes and blending them in the right proportions for various mix design, the different sizes being stocked in separate stock piles, the materials should be stock piled preferably a day before use. The grading of coarse and fine aggregate should be checked as frequently as possible, the frequency for a given job being determined by the Engineer in charge to ensure that the suppliers are maintaining the uniform grading with that of the samples used in the preliminary tests.

In proportioning concrete, the quantity of both cement and aggregate should be determined by weight. Water should be either measured by volume in calibrated tanks or weighed. All measuring equipment shall be maintained in a clean serviceable condition and their accuracy periodically checked.

Cement

Cement to be used on the work shall comply with the requirements of Indian Standard Specification of 43 grade Ordinary Portland Cement. In case of use of 53 grade cement is allowed, the contractor will have to take adequate measures to reduce heat of hydration like curing etc. However the 53 grade cement shall conform to relevant IS Code.

Large stock of cement shall not be kept at the work but only sufficient quantities to ensure continuity of work. The age of cement at the time of delivery to the site shall not be more than two months and the cement shall be used in the work within three months thereafter. The contractor shall provide and maintain a proper and efficient storage shed and shall be raised at least 30 cm above the ground in order to protect the bags from dampness. No cement damaged by exposures or otherwise will be

allowed to be used on the works, but shall be removed at once from the site. Cement shall be used in accordance with "First come First out" rule i.e. take out the oldest cement first.

The contractor shall note the following points:

- a) Cement carrying ISI mark on every bag will only be purchased and will be permitted for use on works.
- b) The contractor shall buy cement from the dealer approved by the manufacturer. Manufacturers test certificate covering the particular batch from which supply has been made by the dealer shall also be submitted.
- c) The contractor shall construct and maintain in a good condition a cement godown of adequate capacity at the site of the work for proper storage of cement, the purchase of cement shall be so scheduled as to allow reasonable time for sampling and testing.
- d) Compressive tests and testing other properties of cement shall be carried out as and when required as per IS :516-1959.
- e) The Contractor shall inform the Engineer-in-charge of receipt of each delivery and shall forward to him the manufacturer's certificate together with the invoice stating the quantity delivered the name and address of the manufacturer.
- f) The contractor shall maintain records for Material received and consumed for Steel reinforcement, Cement, Aggregates, NP3 Pipe, Paver Blocks M40 and M25 grade and Sealant and submit the copy fortnightly to the Engineer-in-charge.

Admixtures

Admixtures shall be allowed to improve workability only if there is proved evidence that neither the strength nor the other requisite qualities of concrete and / or steel, accessories, grout are impaired by their use. The use of admixtures containing calcium chloride, fluorides, nitrates and sulphates is prohibited. The Engineers decision on all matters relating to the use of admixtures shall be final.

Admixtures shall be stored in a suitable weatherproof shed/ building. Any material which has deteriorated or which has been contaminated or damaged whether during transit or at site shall be immediately removed from the site and replaced at contractors own expense.

Fine Aggregate

It shall conform to the requirements of IS: 383 and relevant portion of IS: 515. It shall be chemically inert, strong, hard, durable, of limited porosity, free from adherent coatings, clay lumps, coal and coal residues, and shall not contain any organic matter or other admixtures that may cause corrosion of reinforcement or impair the strength of durability of the concrete. The maximum quantity of the deleterious materials shall not exceed the limits specified in the relevant Indian standard specifications.

Fine aggregates to be used in concrete shall be sieved through 4.75 mm size sieve.

The natural sand shall have grading conforming to one of the four grading limits given in the following table :

Table

IS designation	Sieve	Percentage Passing

	Grading Zone I	Grading Zone II	Grading Zone III	Grading Zone IV
10 mm	100	100	100	100
4.75 mm	90-100	90-100	90-100	95-100
2.36 mm	60-95	75-100	85-100	95-100
1.18 mm	30-70	55-90	75-100	90-100
600 micron	15-34	35-59	60-79	80-100
300 micron	5-20	8-30	12-40	15-50
150 micron	0-10	0-10	0-10	0-15

(When grading falls outside the limits of any particular grading zone of sieves, other than 600 micron sieve, by a total amount not exceeding 5% , it shall be regarded as falling within the grading zone).

Coarse Aggregate

Shall conform with the requirements of IS:383 and relevant portions of IS:515. It shall consist of hard, dense, durable, uncoated crushed rock, use of gravel shall be allowed only if specified in the schedule of quantities. Aggregates shall be free from soft, friable, thin or flaky pieces. It shall be free from injurious amounts of alkali and organic matter other than deleterious materials. The maximum quantity of deleterious materials shall not exceed the limits specified in the relevant Indian standard specifications.

Coarse aggregates shall be obtained in single sizes conforming to the grading given in the following table in respect of each nominal size. Single sized aggregates shall be blended in suitable proportions to obtain a desired grading of coarse aggregates. At the discretion of the Engineer in charge use of graded aggregates shall be allowed provided the grading conforms to the limits specified in the following table under Column B.

Table

IS Sieve designation	A % Passing for single sized aggregate of nominal size						B % passing of graded aggregate of nominal size			
	63 mm	40 mm	20 mm	16 mm	12.5 mm	10 mm	40 mm	20 mm	16 mm	12.5 mm
80 mm	100	--	--	--	--	--	100	--	--	--
63 mm	85-100	100	--	--	--	--	--	--	--	--
40 mm	0-30	85-100	100	--	--	--	95-100	100	--	--
20 mm	0-5	0-20	85-100	100	--	--	30-70	95-100	100	100
16 mm	--	--	--	85-	100	--	--	--	90-	--

				100					100	
12.5 mm	--	--	--	--	85-100	100	--	--	--	90-100
10 mm	0-5	0-5	0-20	0-30	0-45	85-100	10-35	25-55	30-70	40-85
4.75 mm	--	--	0-5	0-5	0-10	0-20	0-5	0-10	0-10	0-10
2.36 mm	--	--	--	--	--	0-5	--	--	--	--

In selecting coarse as well as fine aggregates, the contractor shall, satisfy himself that the source is suitable and adequate for regular supply and a watch shall be maintained that the particle shape and grading remain reasonable uniform throughout the progress of work. If directed by Engineer in charge the aggregates shall be washed at contractor's expense.

For both fine and coarse aggregates, preliminary tests shall be carried out for physical characteristics, limits of deleterious substances, soundness, etc. prior to commencement of work and also when the source of supply is changed.

Water

Water used for both mixing and curing shall be free from injurious amounts of deleterious materials. Potable water is generally considered satisfactory for mixing and curing concrete.

Reinforcement

The Contractor shall procure the required quantity of steel from the reputed manufacturers confirming to IS: 1786 and mill certificates shall be furnished for the approval of reinforcing steel. The contractor shall make necessary arrangements for transporting, storing, maintaining & protecting the materials required for the work.

Tests shall be carried out as per the instructions of the Engineer-in-charge. Reinforcing bars shall be stored on site on timber or concrete supports suitably spaced and of sufficient height to keep steel clear of the ground. Reinforcing steel shall be stored separately section wise. All rejected steel shall be immediately removed from the site at the Contractors own expense.

All reinforcement shall be TMT bars and shall conform with the requirements of relevant IS specifications for deformed steel. All reinforcement when placed in position shall be clean and free from loose mild scales, dust, loose rust and coats of paints, oil or other coatings which may destroy or reduce bond.

Welded joints may be allowed only when tests shall be made to prove that the joints are of the full strength of the bars connected. Welding of reinforcement shall be done in accordance with the recommendations of relevant Indian standards for welding of mild steel bars used in reinforced cement concrete.

1.2.14 Concrete Mix Design:

Concrete mix for various specified design strength shall be worked out by the contractor by any of the recognized method of mix design. There shall be one or two or more mix designs for same grade of concrete for different workability as required for different structural members.

The selected mix proportion shall ensure that workability of the fresh concrete is suitable for conditions

of handling and placing, so that after compaction it surrounds all reinforcement, ducts etc. and completely fills the formwork. When the concrete is hardened its quality shall be such as to comply with the strength, durability and other requirements, taking into account the conditions to which it will be exposed.

The preliminary mix design shall assume only fair control, unless the contractor can prove from his past experience that he is capable of achieving a high degree of control. Before arriving at average strength values the contractor shall give due regard to the criteria of acceptance for preliminary test as stipulated in IS: 456 consecutive cubes shall constitute a test and the average strength of 3 consecutive cubes tested shall not be less than the stipulated strength for preliminary tests. The design mix and control shall be accepted if only one out of three cubes may give a value less than the specified strength. The contractor shall prepare well in advance all calculations, tabulations, graphs, pertaining to concrete mix design and preliminary test results and submit the copies of Engineer in charge for their instructions. Only that mix which is approved in writing by the Engineer in charge shall be allowed on the works. However it shall be clearly understood that such approval shall not absolve the contractor of his responsibility for compliance of works tests results.

1.2.15 Classes of Concrete

Table

Class	Maximum size of Aggregate mm	Minimum Crushing Strength Kg / sq.cm				Minimum Mixing Time in Minutes	Minimum Cement in concrete (Kg/Cum)	W/C
		Preliminary Test		Work Test				
		7 days	28 days	7 days	28 days			
M10 (1:3:6)	20	100	135	70	100	2	220	0.55
DLC	25	140	---	100	---	2	150	0.65
M20	20	165	235	140	200	2	320	0.45
M40 (PQC)	20	350	500	280	400	2	420	0.40

Note: No claim for excess cement used shall be entertained. If this minimum cement content is not sufficient to produce in the field the concrete of the strength specified in the BOQ, it shall be increased as necessary without additional compensation under the contract.

Note:- Please refer BOQ of Vol III, for minimum cement in concrete(Kg/Cum)

1.2.16 Mixing , placing of concrete and Measurement of materials

The following specifications shall apply for RM C Plant / Batching Plant. The batching plant should be well equipped with digitally controlled computerized operation to get the print out of

materials incorporated the particular of batch mix. The contractor has to certify the batch mix daily with authorized signatory and calibration of the batching plant shall be done periodically.

- IS 4925 - Specification for concrete batching and mixing plant.
- IS 5892 - Specification for concrete transit mixer and agitator.

Concrete shall be conveyed and placed by mechanical operated equipments after approval of the entire procedure by the Engineer. The slump shall be held to the minimum necessary for conveying concrete by this method. The concrete mix shall be specially designed to suit spreading.

The charges for shuttering, vibrating, spreading and part load of concrete, non accessibility of site etc. will not be entertained and paid for. These rates are deemed to be included in the item rate for concrete indicated against respective items of work.

Every transit mixer will carry delivery ticket, which will have minimum following details:-

Date.

Ticket No.

Location of Work

Grade of concrete.

Specified workability

Cement content and grade of cement

Time of loading

Quality of concrete.

When the truck arrives at site, the drum should always be speeded to about 10 to 15 rev/min for at least 3 minutes, to make sure that the concrete is thoroughly mixed and uniform, before discharge.

Cement

In proportioning concrete, the quantity of both cement and aggregates shall be determined by weight. Where the weight of cement is determined by accepting the maker's weight per bag, a number of bags as directed by the Engineer in charge shall be weighed separately to check the net weight. Where cement is weighed on the site and not in bags it shall be weighed separately from the aggregates.

Aggregate

Aggregate shall be batted by weight in a mechanical weigh batcher or batching plant unless otherwise specifically permitted by the Engineer in charge to volumetric batching where volumetric proportion are allowed with the consent of the engineer in charge, the conversion from weight to that of volume shall be on the basis of dry bulk densities of the aggregates.

Water

Water shall be measured either by volume in calibrated tanks or weighed. Water shall not be measured using ordinary buckets. Measurement of water to control and maintain water cement ratio is utmost importance and adequate attention shall be given by the contractor to the satisfaction of the Engineer in charge.

All measuring equipment shall be of approved type and maintained in serviceable condition and their

accuracy is to be periodically checked.

1.2.17 Specifications For Ready Mixed Concrete

- a) All specification for cement concrete shall also be applicable to Ready Mix concrete.
- b) The tenderer shall submit along with the tender, a copy of letter of consent from the RMC plant owner to the effect that he would agree to do the RMC work for the said contract, If the tenderer do not possess their own RMC plant.
- c) Ready mix concrete prepared and transported will be as per IS 4926 of 1976 or the latest IS code. Design mix of specific grade of Concrete supplied by the RMC manufacturer shall be submitted by the contractor.
- d) No dry mix shall be brought to the site and water added thereafter.
- e) The following specifications shall apply for RMC.
 - IS 4925 - Specification for concrete batching and mixing plant.
 - IS 5892 - Specification for concrete transit mixer and agitator.
 - IS 7242 - Specification for concrete spreader.

Concrete shall be conveyed and placed by mechanical operated equipments after approval of the entire procedure by the Engineer. The slump shall be held to the minimum necessary for conveying concrete by this method. The concrete mix shall be specially designed to suit pumping. Care shall be taken to avoid stoppages in work once pumping has started. The spreading shall be done by mobile boom and not by any manual method. The measurement for RMC will be made as per the dimensions of the element cast at site in cubic meter not as per the delivery challan of the RMC manufacturer.

The charges for shuttering, vibrating, spreading, pumping detention time with spreading mobile placer booms, part load of concrete, non accessibility of site etc. will not be entertained and paid for. These rates are deemed to be included in the item rate for concrete indicated against respective items of work.

f) Every transit mixer will carry delivery ticket, which will have minimum following details:-

- 1) Name of manufacturer and Depot
- 2) Serial no. of ticket.
- 3) Date.
- 4) Ticket No.
- 5) Name of contractor to whom the RMC is being supplied
- 6) Location of contract
- 7) Grade of concrete.
- 8) Specified workability
- 9) Cement content and grade of cement
- 10) Time of loading
- 11) Quality of concrete.
- 12) Time of Discharge

When the truck arrives at site, the drum should always be speeded to about 10 to 15 rev/min for at

least 3 minutes, to make sure that the concrete is thoroughly mixed and uniform, before discharge.

1.2.18 Testing of Ready Mixed Concrete

The sampling and testing requirements for ready mixed concrete are no different from those for site mixed concrete. The contractor has to make sure the load is of the right workability, before discharge. After ensuring that the concrete has been uniformly mixed, a sample is taken from the first 0.5 cum. of concrete discharge, and a slump (or compacting factor) test on the sample is done. If the result complies with the specified requirements, then the load shall be accepted. If the results fall outside the limits, a further sample shall be taken from the second 0.5 Cum. of the discharge, and if this is satisfactory, load shall be accepted, if not the concrete is regarded, as outside the specification range. The specified slump is, while carrying out above tests; it may vary by ± 10 mm, as per IS- 4926:1976. Testing materials shall be as per requirement of IS: 4926 and the admixture used shall confirm to IS: 9103-1979.

All taxes/ duties etc. including excise, WCST etc. will be borne by the contractors and not by the NMPA. No extra payment will be made for use of admixtures.

The defect liability period of one year will be that of the main tenderer.

The shuttering for the RMC work shall be capable to resisting the pumping pressure of concrete. The cost of shuttering is deemed to be included in the rate for respective item rate.

B. Works

1. Shifting Of Dwarf Wall

Shifting of Dwarf wall to designated location as directed by the Department, including cost of transportation, loading and unloading charges, crane charges, truck charges, and all other incidental charges etc. complete.

2. Demolishing

Demolishing cement concrete manually/ by mechanical means including disposal of material to the appropriate disposal area as per direction of Engineer-in-charge.

3. Removing existing Railway track

Cutting and removing the existing Railway track of mixed gauge along with the check rails provided and to be stacked at the location as directed by the Engineer in Charge. The rates include cost of exposing the rails, cutting, crane charges for lifting & transportation, and labour cost, Disposal of wooden sleepers etc., complete.

2. 4.5 SPECIFICATIONS FOR READY MIXED CONCRETE

4.5.1 Ready Mixed Concrete - Concrete delivered at site or into the purchaser's vehicle in a plastic condition and requiring no further treatment before being placed in the position in which it is to set and harden.

4.5.1.1 Agitation-The process of continuing the mixing of concrete at a reduced speed during transportation to prevent segregation.

4.5.1.2 Agitator-Truck mounted equipment designed to agitate concrete during transportation to the site of delivery.

4.5.1.3 Truck Mixer-A mixer generally mounted on a self-propelled chassis, capable of mixing the ingredients of concrete and of agitating the mixed concrete during transportation.

4.5.2 Types

For the purpose of this standard, the ready-mixed concrete shall be one of the two types, according to the method of production and delivery as specified in 4.5.3.1 and 4.5.3.2.

4.5.2.1 Centrally-mixed concrete – Concrete produced by completely mixing cement, aggregates, admixtures, if any and water at a stationary central mixing plant and delivered in containers fitted with agitating devices, except that when so agreed to between the purchaser and the manufacturer, the concrete may be transported without being agitated.

4.5.2.2 Truck-mixed concrete - Concrete produced by placing cement, aggregates and admixtures, if any, other than those to be added with mixing water, in a truck mixer at the batching plant, the addition of water and admixtures to be added along with mixing water, and the mixing being carried out entirely in the truck mixer either during the journey or on arrival at the site of delivery. No water shall be added to the aggregate and cement until the mixing of concrete commences.

4.5.3. Materials

4.5.3.1 Cement - The cement used shall be ordinary Portland cement or low heat Portland cement conforming to IS: 269-1989 or 8112-1989 or 1226:1987 or Portland slag cement conforming to IS: 455-1989 or 'Portland-pozzolana cement conforming to IS: 1489-1991 or rapid hardening Portland cement conforming to IS: 8041-1976 as may be specified by the purchaser at the time of placing the order. If the type is not specified, ordinary Portland cement shall be used.

Fly ash when used for partial replacement of cement, shall conform to the requirements of IS:3812 - 1981

4.5.3.2. Aggregates - Unless otherwise agreed to between the purchaser and the manufacturer, the aggregates shall conform to IS: 383-1970. Fly ash when used as fine aggregate shall conform to the requirements of IS: 3812-1981.

4.5.3.3. Water used for concrete shall conform to the requirements of IS: 456-2000.

4.5.3.4, Admixtures – Admixtures shall only be used when so agreed to between the purchaser and the manufacturer. The admixtures shall conform to the requirements of IS: 456-2000, and their nature, quantities and methods of use shall also be specified. Fly ash when used as an admixture for concrete shall conform to IS: 3812-1981.

4.5.3.5, Measurement and storage of materials – Measurement and storage of materials shall be done in accordance with the requirements of IS: 456-2000.

4.5.4 Basis of supply

4.5.4.1 Depending upon the agreement between the purchaser and the manufacturer, the ready-mixed concrete shall be manufactured and supplied on either of the following basis:

a) Specified strength based on 28-day compressive strength of 15-cm cubes tested in accordance with IS: 456-2000.

b) Specified mix proportion.

Note - Under special circumstances and subject to the agreement between the purchaser and the supplier, strength of concrete in (a) above may be based on 28-day or 7-day flexural strength of concrete instead of compressive strength of 15-cm cube tested in accordance with IS: 456-2000.

When the concrete is manufactured and supplied on the basis of specified strength, the responsibility for the design of mix shall be that of the manufacturer and the concrete shall conform to the requirements.

When the concrete is manufactured and supplied on the basis of specified mix proportion, the responsibility for the design of the mix shall be that of the purchaser and the concrete shall conform to the requirements.

4.5.4.2 Measurement of Ready-mixed concrete

The basis of purchase shall be the cubic meter of plastic concrete as delivered to the purchaser.

The volume of plastic concrete in a given batch shall be determined from the total mass of the batch divided by the actual mass per m³ of concrete. The total mass of the batch shall be calculated either as the sum of the masses of all materials, including water, entering the batch or as the net mass of concrete in the batch as delivered. If the purchaser wishes to verify the total mass, of the batch, this shall be obtained from the gross and tare masses of the vehicle on a stamped weigh bridge. The mass per m³ shall be determined in accordance with the method given in IS:1199-1959.

4.5.5 General requirements

4.5.5.1. In addition to the requirements specified in this standard and subject to such modifications as may be agreed to between the purchaser and the manufacturer at the time of placing order, the ready-mixed concrete shall generally comply with the requirements of IS:456-2000.

Unless otherwise agreed to between the purchaser and the supplier, the minimum quantity of cement and the details regarding proportioning and works control shall be in accordance with IS:456-2000.

When a truck mixer agitator is used for mixing or transportation of concrete, no water from the truck-water system or from elsewhere shall be added after the initial introduction of the mixing water for the batch, except when on arrival at the site of work, the slump of the concrete is less than that specified; such additional water to bring the slump within required limits shall be injected into the mixer under such pressure and direction of flow that the requirements for uniformity specified in Appendix. A are met.

Unless otherwise agreed to between the purchaser and the supplier, when a truck mixer or agitator is used for transporting concrete, the concrete shall be delivered to the site of work and discharge shall be complete within 1½ hour (when the prevailing atmospheric temperature is above 20° C) and within 2 hours (when the prevailing atmospheric temperature is at or below 20° C) of adding the mixing water to the dry mix of cement and aggregate or of adding the cement to the aggregate, whichever is earlier.

4.5.5.2 Temperature - The temperature of the concrete at the place and time of delivery shall be not less than 5° C. Unless otherwise required by the purchaser, no concrete shall be delivered, when the site temperature is less than 2.5° C and the thermometer reading is falling.

The temperature of the concrete shall not exceed 5° C above the prevailing shade temperature, when the shade temperature is over 20° C. The temperature of concrete mass on delivery shall not exceed 40° C.

4.5.5.3. Sampling and testing - Adequate facilities shall be provided by the manufacturer for the purchaser to inspect the materials used, the process of manufacture and the methods of delivery of concrete. He shall also adequate facilities for the purchaser to take samples of the materials used.

Unless otherwise agreed to between the purchaser and the supplier, the sampling and testing of concrete shall be done in accordance with the relevant requirements of IS: 456-2000, IS:1199-1959 and IS: 516-1959

Consistency or workability – The tests for consistency or workability shall be carried out in accordance with requirements of IS: 1199-1959 or by such other method as may be agreed to between the purchaser and the manufacturer.

4.5.5.4. Strength test – The compressive strength, and flexural strength tests shall be carried out in accordance with the requirements of IS: 516-1959 and the acceptance criteria for concrete whether supplied on the basis of specified strength or on the basis of mix proportion, shall conform to the requirements mentioned below.

Compressive strength - The concrete shall be deemed to comply with the strength requirements when both the following conditions are met:

a) The mean strength determined from any group of four consecutive test results complies with the appropriate limits in col. 2 of Table.

b) Any individual test result complies with the appropriate limits in col.3 of Table.

Flexural strength - When both the following conditions are met, the concrete complies with the specified flexural strength.

a) The mean strength determined from any group of four consecutive test results exceeds the specified characteristic strength by at least 0.3 N/mm².

b) The strength determined from any test result is not less than the specified characteristic strength less 0.3 N/mm².

4.5.5.5. Quantity of concrete represented by strength test results - The quantity of concrete represented by a group of four consecutive test results shall include the batches from which the first and last samples were taken together with all intervening batches.

For the individual test result requirements given in col.2 of Table 9 or in item (b) of 16.2 only the particular batch from which the sample was taken shall be at risk.

Where the mean rate of sampling is not specified the maximum quantity of concrete that four consecutive test results represent shall be limited to 60m³.

If the concrete is deemed not to comply, the structural adequacy of the parts affected shall be investigated and any consequential action as needed shall be taken.

Concrete of each grade shall be assessed separately.

Concrete is liable to be rejected if it is porous or honey-combed, its placing has been interrupted without providing a proper construction joint, the reinforcement has been displaced beyond the tolerances specified, or construction tolerances have not been met. However, the hardened concrete may be accepted after carrying out suitable remedial measures to the satisfaction of the engineer-in-charge.

Table 9 Characteristic compressive strength compliance requirement

Specified Grade	Mean of Group of 4 Non-Overlapping Consecutive Test Results in N/mm ² .	Individual Test Results in N/mm ² .
(1)	(2)	(3)
M15	$\geq f_{ck} + 0.825 \times$ established standard deviation (rounded off to nearest 0.5 N/mm ²).	$\geq f_{ck}$ N/mm ² .
M 20 or above	$f_{ck} + 3$ N/mm ² , whichever is greater + 0.825 x established standard deviation (rounded off to nearest 0.5 N/mm ²) or +4 N/mm ² , whichever is greater	$\geq f_{ck}$ N/mm ² .
Note:- In the absence of established value of standard deviation, the value given in Table 8 of IS:456-2000 may be assumed, and attempt should be made to obtain results of 30 samples as early as possible to establish the value of standard deviation.		

4.5.5.6 Cost of testing – Unless otherwise agreed to between the purchaser and the manufacturer, the cost of the tests carried out in accordance with the requirements of this specification shall be borne as follows:

- a) By the manufacturer if the results show that the concrete does not comply with the requirements of this standard.
- b) By the purchaser if the results show that the concrete complies with the requirements of this standard.

4.5.5.7 Manufacturer's records and certificates – The manufacturer shall keep batch records of the quantities by mass of all the solid materials, of the total amount of water used in mixing and of the results of all tests. If required by the purchaser, the manufacturer shall furnish certificates, at agreed intervals, giving this information.

4.5.6. Concrete manufactured and supplied on the basis of specified strength

4.5.6.1 The purchaser shall supply the following information for guidance of the manufacturer :

- a) The type of cement to be used;
- b) The maximum size and type of the aggregate;
- c) The type of admixtures to be used;
- d) The minimum acceptable compressive strength of flexural strength or both, determined from samples of plastic concrete taken at the place and time of delivery, in accordance with requirements of IS:456-2000.
- e) The slump or compacting factor or both, or other requirements for consistency or workability at the place and time of delivery of the concrete;
- f) The ages at which the test cubes or beams are to be tested, and the frequency and the number of tests to be made; and
- g) Any other requirements.

4.5.6.2 Tolerances – Unless otherwise agreed to between the purchaser and the manufacturer, the concrete shall be deemed to comply with the requirement of these standard, if the results of tests where applicable, lie within the tolerances specified.

4.5.6.3. Consistency of workability – The slump (average of two tests) shall not differ from the specified value by ± 10 mm for a specified slump of 75mm or less and ± 25 mm when the specified slump is greater than ± 75 m. The compacting factor average of two tests shall be within 0.03 of the value specified. If any other method of determining consistency is to be used, a suitable tolerance shall be agreed to between the purchaser and the manufacturer. The test for consistency or workability shall be completed within 15 minutes of the time of receipt of the ready-mixed concrete at the site.

4.5.6.4. Aggregates – When tested in accordance with IS: 2386(Part I)-1963, the quantity of aggregate larger than the maximum size specified by the purchaser shall not exceed 5 percent of the quantity of coarse aggregate and all such excess shall pass through sieve (conforming to IS: 460 (Part 1-3)-1985 of the next higher size.

4.5.7. Concrete manufactured and supplied on the basis of mix proportion

4.5.7.1 The purchaser shall supply the following information for guidance of the manufacturer:

- a) The type of the cement to be used;
- b) The sizes and types of the aggregate;
- c) The type of admixtures to be used;
- d) The proportions of the mix including the maximum water cement ration at the place and time of delivery of the concrete;
- e) The minimum mixing time after addition of the water; and
- f) Any other requirements.

Tolerances – Unless otherwise agreed to between the purchaser and the manufacturer, the concrete shall be deemed to comply with the requirements of this standard, if the result of tests where applicable, lie within the tolerance specified.

Cement content – The cement content, as shown by the samples taken, shall be not less than 95 percent of that specified.

Ratio of coarse to fine aggregates – The ratio of coarse to fine aggregates, as indicated by the sample taken, shall neither exceed nor fall below the ration specified by the purchaser by more than 10 percent.

Water/ cement ratio - ± 5 percent of the specified value.

Consistency or workability – The slump shall not differ from the amount specified by ± 10 mm for a specified slump of 75 mm or less and ± 25 mm when the specified a slump is greater than 75mm. The compacting factor shall be within ± 0.03 of the value specified. If any other method of determining consistency is used, a suitable tolerance shall be agreed to between the purchaser and the supplier.

APPENDIX A

Concrete uniformity requirement

A-1 Tests

A-1.1 The variation within a batch as provided in Table 10 shall determined for each property listed as the difference between the highest value and the lowest value obtained from the different portions of the same batch. For this specification the comparison shall be between two samples, representing the first and last portions of the batch being tested. Test results conforming to the limits of five of the six tests listed in Table I shall indicate uniform concrete within the limits of this specification. Analysis of concrete samples shall be made in accordance with the relevant requirements of IS: 1159-1959.

A.2. Coarse aggregate content

A-2.1 Coarse aggregate content shall be determined using the following equation:

$$p = \frac{c}{b} \times 100$$

Where

P= Percentage of coarse aggregate by mass in concrete;

c= saturated surface dry mass in kg of aggregate retained on 4.75 mm IS Sieve, resulting from washing all material finer than this sieve from the fresh concrete; and

b= mass of sample, in kg of fresh concrete in unit mass container.

Table 10 Requirements for uniformity of concrete

Sl. No.	Test	Requirement expressed as maximum permissible difference in results of tests or samples representing the first and last portions or concrete batch
1	2	3
i)	Mass per cubic meter calculated to an air-free basis	16 kg/m ³
ii)	Air-content, percent by volume of concrete	1.0
iii)	Slump:	
	If average slump is 10cm or less	2.5 cm
	If average slump is 10 to 15 cm	3.8 cm
iv)	Coarse aggregate content, percent (portion by mass of each sample retained on 4.75-mm IS Sieve)	6.0
v)	Unit mass of air-free mortar, percent based on average for all comparative samples tested	1.6
VI)	Average compressive strength at 7 days for each comparative test specimens, percent	7.5

A-3. Unit mass of air free mortar

A-3.1 Unit mass of air free mortar shall be calculated as follows:

$$M = \frac{b - c}{V = \left\{ \frac{V \times A}{100} + \frac{c}{1000G} \right\}}$$

Where

M= Unit mass of air free mortar in Kg/m³

b= mass of concrete sample in unit mass container in kg,

c= saturated-surface-dry mass of aggregate in kg retained on 4.75mm IS Sieve,

V= Volume of unit mass container in m³

A= air content of concrete in percent measured in accordance with the relevant requirements of IS:1199-1959*, and

G = specific gravity of coarse aggregate.

4.6 SPECIFICATIONS FOR REINFORCED CEMENT CONCRETE WORK.

General - Reinforced cement concrete work may be cast-in-situ or Precast as may be directed by engineer according to the nature of work. Reinforced cement concrete work shall comprise of the following which may be paid separately or collectively as per the description of the item of work.

- a) Form work (Centering and shuttering)

- b) Reinforcement
- c) Concreting - 1) Cast-in-situ 2) Precast

4.6.1 Materials

4.6.1.1 Water, cement, fine and coarse aggregate shall be as specified under respective clauses of mortars and section 04-concrete work as applicable.

4.6.1.2 Steel for reinforcement

The steel used for reinforcement shall be any of the following types -

- a) Mild steel sand medium tensile bars conforming to IS: 432 (part I)
- b) Hard drawn steel wire conforming to IS: 432 (part II)

High strength deformed steel bars conforming to IS: 1786

- c) Hard drawn steel wire fabric conforming to IS: 1566
- d) Structural steel section conforming to IS: 2062-1999

Types and grades - Reinforcement supplied in accordance with this standard shall be classified into the following types -

a) Mild steel bars - It shall be supplied in the following two grades

- i) Mild steel bars grade I designated as Fe 410-S
- ii) Mild steel bars grade II designated as Fe 410-O.

b) Medium tensile steel bars, grade II designated as Fe-540-W-HT.

Mild steel and medium tensile steel - Physical requirements are given in Table 11.

Table 11

Sl No	Type and nominal size Of bars	Ultimate tensile stress N/mm ² minimum	Yield stress N/mm ² minimum	Elongation Percent
1	Mild steel grade I For bars up to and including 20 mm	410	250	23
	For bars over 20 mm up to and including 50 mm	410	240	23
2	Mild steel grade I For bars up to and including 20 mm	370	225	23
	For bars over 20 mm up to and including 50 mm	370	215	23
3	Medium tensile steel For bars up to & including 16 mm	540	350	20
	For bars over 16 mm, up to And including 32 mm	540	340	20
	For bars over 32 mm, up to	510	330	20

	And including 50 mm			
--	---------------------	--	--	--

Elongation percent on gauge length $5.65 \sqrt{so}$ where so is the cross section area of the test piece.

Note-1. Grade (II) Mild steel bars are not recommended for the use in structures located in the earthquake zone subjected to serve damage and for structures subjected to dynamic loading (other than wind loading) such as railway and highway bridges.

2. Welding of reinforcement bars covered in this specification shall be done in accordance with the requirements of IS: 2751.

Nominal mass / weight - The tolerance on mass/weight for round and square bars shall be the percentage given in Table.12 of the mass/weight calculated on the basis that the masses of the bar/wire of nominal diameter and of density 0.785 kg / cm³ or 0.00785 kg / mm³.

Table 12 (Tolerance on nominal mass)

Nominal size In mm	Tolerance on the nominal mass percent		
	Batch	Individual Sample +	Individual sample for coil(-x-)
a) up to and including 10	± 7	± 8	± 8
b) over 10, up to and including 16	+5	-6	+6
c) over 16	± 3	-4	± 4

+ for individual sample plus tolerance in not specified

(x) for coil batch tolerance is not applicable

Tolerance shall be determined in accordance with method given in IS 1786-1985

Tests - Following type of lab test shall be carried out

- 1) Tensile test - This shall be done as per IS: 1608
- 2) Bend test - This shall be done as per IS: 1599
- 3) Re-test - This shall be done as per IS: 1786
- 4) Rebend test -This shall be done as per IS: 1786

Should any one of the test pieces first selected fail to pass any of the tests specified above, two further samples shall be selected for testing in respect of each failure. Should the test pieces from both these additional samples pass, the materials represented by the test samples shall be deemed to comply with the requirement of the particular test. Should the test piece from either of these additional samples fail, the material represented by the test samples shall be considered as not having complied with standard. High strength deformed bars & wires shall conform to IS: 1786. The physical properties for all sizes of steel bars are mentioned below in Table 13.

Table 13

Sl. No	Property	Grade		
		Fe 415	Fe 500	Fe 550
1	0.2% proof Stress/Yield stress, in. N/mm ²	415	500	550

	Elongation, percent min. on gauge Length 5.65 A, Where A is the X-sectional Area of the test piece	14.5	12	8
3	Tensile strength	10 % more than actual 0.2 % proof stress but not less than 465 N/mm ²	8 % more than actual 0.2 % proof stress but not less than 545 N/mm ²	6 % more than actual 0.2 % proof stress but not less than 585 N/mm ²

Tests - Selection and preparation of test sample. All the tests pieces shall be selected by the engineer or his authorised representative either-

- a) From cutting of bars or
- b) If he so desires, from any after it has been cut to the required or specified size and the test piece taken from any part of it.

In neither case, the test pieces shall be detached from the bar or coil except in the presence of the engineer or his authorised representative.

The test pieces obtained in accordance with as above shall be full sections of the bars as rolled and subsequently cold worked and shall be subjected to physical tests without any further modifications. No deductions in size by machining or otherwise shall be permissible. No test piece shall be enacted or otherwise subject to heat treatment. Any straightening which a test piece may require shall be done cold.

Tensile test - This shall be done as per IS: 1599.

Re-test - This shall be done as per IS: 1786.

4.6.1.3 Stacking and storage - Steel for reinforcement shall be stored in such a way as to prevent distorting and corrosion. Bars of different classifications, sizes and lengths shall be stored separately to facilitate issue in such sizes and lengths to cause to minimum wastage in cutting from standard length.

4.6.3. SPECIFICATIONS FOR REINFORCEMENTS IN CONCRETE

4.6.3.1. General requirements - Steel conforming to para 4.6.1.2. for reinforcement shall be clear and free from loose mill scales, dust, loose rust, coats of paints, oil or other coatings which may destroy or reduce bond. It shall be stored in such a way as to avoid distortion and to prevent deterioration and corrosion. Prior to assembly of reinforcement on no account any oily substance shall used for removing the rust.

(1). Assembly of reinforcement - Bars shall be bent correctly and accurately to the size and shape as shown in the detailed drawing or as directed by engineer. Preferably bars of full length shall be used. Necessary cutting and straightening is also included. Over lapping of bars, where necessary shall be done as directed by the engineer. The overlapping bars shall not touch each other and these shall be kept apart with concrete between them by 25 mm or 1 ¼ times the maximum size of the coarse aggregate whichever is greater. But where this is not possible, the overlapping bars shall be bound together at intervals not exceeding twice the dia. Of such bars with two strands annealed steel wire of

0.90 mm to 1.6 mm twisted tight. The overlaps / splices shall be staggered as per directions of the engineer. But in no case the over lapping shall be more than 50% of cross sectional area at one section.

(2). Bonds and hooks forming end anchorages - Reinforcement shall be bent and fixed in accordance with procedure specified in IS 2502, code of practice for bending and fixing of bars for concrete reinforcement. The details of bends and hooks are shown below for guidance.

a) U-Type hook - In case of mild steel plain bars standard U-type hook shall be provided by bending ends of rod into semicircular hooks having clear diameter of the bar

Note-In case of work in seismic zone, the size of hooks at the end of the rod shall be eight times the diameter of bar or as given in the structural drawing.

b) Bends - Bend forming anchorage to a M.S. plain bar shall be bent with an internal radius equal to two times the diameter of the bar with a minimum length beyond the bend equal to four times the diameter of the bar.

(3). Anchoring bars in tension - Deformed bars may be used without end anchorages provided, development length requirement is satisfied. Hooks should normally be provided for plain bars in tension. Development length of bars will be determined as per clause 25.2.1 of IS: 456-2000.

(4). Anchoring bars in compression - The anchorage length of straight bar in compression shall be equal to the 'Development length' of bars in compression as specified in of IS: 456-2000. The projected length of hooks, bends and straight lengths beyond bend, if provided for a bar in compression, shall be considered for development length.

(5). Binders, stirrups, links and the like - In case of binders, stirrups, links etc. the straight portion beyond the curve at the end shall be not less than eight times the nominal size of bar.

(6). Welding of bars - Whenever facility for electric arc welding is available, welding of bars shall be done in lieu of overlap. The location and type of welding shall be got approved by the engineer. Welding shall be as per IS: 2751 for mild steel bars and for cold worked bars.

4.6.3.2 Placing in position - Fabricated reinforcement bars shall be placed in position as shown in the drawings or as directed by the engineer. The bars crossing one another shall be tied together at every intersection with two stands of annealed steel wire 0.9 to 1.6 mm thickness twisted tight to make the skeleton of the steel work rigid so that the reinforcement does not get displaced during deposition of concrete.

Track welding in crossing bars shall also be permitted in lieu of bending with steel wire if approved by engineer.

The bars shall be kept in correct position by the following methods -

a) In case of beam and slab construction precast cover blocks of cement mortar 1:2 about 4x4 cm section and of thickness equal to the specified cover shall be placed between the bars and shuttering, so as to secure and maintain the requisite cover of concrete over reinforcement.

b) In case of cantilevered and doubly reinforced beams or slabs, the vertical distance between the horizontal bars shall be maintained by introducing chairs, spacers or support bars of steel at 1.0 meter or at shorter spacing to avoid sagging.

c) In case of columns and walls, the vertical bars shall be kept in position by means of timber

templates with slots accurately cut in them; or with block of cement mortar 1:2 of required size suitably tied to the reinforcement to ensure that they are in correct position during concreting.

d) In case of R.C.C. structure such arches, domes, shells, storage tanks etc. a combination of cover blocks, spaces and templates shall be used as directed by engineer.

Tolerance on placing of reinforcement - Unless otherwise specified by the engineer, reinforcement shall be placed within the following tolerances -

Tolerance in spacing

		Tolerance in spacing
a)	For effective depth 200 mm or less	± 10
b)	For effective depth More than 200 mm	± 15

The cover shall in no case be reduced by more than one third of specified cover or 5 mm which ever is less.

Bending at construction joints - Where reinforcement bars are bent aside at construction joints and afterwards bent back into their original position care should be taken to ensure that at no time the radius of the bend is less than 4 bars diameters for plain mild steel or 6 bar diameters for deformed bars. Care shall also be taken when bending back bars to ensure that the concrete around the bars is not damaged.

4.6.3.3. Measurements - Reinforcement shall be measured in length of different diameters, as actually (not more than as specified in the drawings.) used in the work nearest to a centimeter and their weight calculated on the basis of standard weight given in Table 14 below. Annealed steel wire required for binding or tack welding, including laps and wastages shall not be measured separately, its cost being included in the rate of reinforcement.

Wherever tack welding is used in lieu of binding, such welds shall not be measured. Chairs separators etc. shall be provided as directed by the engineer and measured separately and paid for.

Table 14 Cross-sectional area and mass of steel bar

Nominal size mm	Cross sectional area sq.mm	Mass per meter run kg
6	28.3	0.222
7	38.5	0.302
8	50.3	0.395
10	78.6	0.617
12	113.1	0.888
16	201.2	1.58
18	254.6	2.00
20	314.3	2.47
22	380.3	2.98

25	491.1	3.85
28	616.0	4.83
32	804.6	6.31
36	1018.3	7.99
40	1257.2	9.85
45	1591.1	12.50
50	1964.3	15.42

Note - These are as per clause 5.2 of IS 1786.

4.6.3.4. Rate - The rate for reinforcement shall include the cost of labour and materials required for all operations described above such as cleaning of reinforcement bars, straightening, cutting, as required of directed including tack welding on crossing of bars in lieu of binding with wires.

4.6.4 SPECIFICATIONS FOR CONCRETING

The concrete shall be done as specified. The proportion by volume of ingredients shall be as specified.

4.6.4.1 Consistency - The concrete which will flow sluggishly into the forms and around the reinforcement without any segregation of coarse aggregate from the mortar shall be used. The consistency shall depend on whether the concrete is vibrated on or hand tamped. It shall be determined by slump test as n[prescribed in chapter “ concrete under para 4.2.3 workability”

Where considered necessary, the workability of the concrete may also be ascertained by compacting factor test and VEE BEE consistometer method specified in IS: 1199. For suggested ranges of values of workability of concrete by the above two methods, reference may be made to IS: 456.

4.6.4.2 Placing of concrete

Concreting shall be commenced only after engineer has inspected the centering, shuttering and reinforcement as placed and passed the same. Shuttering shall be clean and free from all shaving, saw dust, pieces of wood, or other foreign material and surfaces shall be treated as prescribed.

In case of concreting of slabs and beams, wooden plank or cat walks of chequered MS plates or bamboo chlies or any other suitable material supported directly on the centering by means of wooden blocks or lugs shall be provided to convey the concrete to the place of deposition without disturbing the reinforcement in any way. Labour shall not be allowed to walk over the reinforcement.

In case of columns and walls, it is desirable to place concrete without construction joints. The progress of concreting in the vertical direction shall be restricted to one meter per hour.

The concrete shall be deposited in its final position in a manner to preclude segregation of ingredients. In deep trenches and footings concrete shall be placed through chutes or as directed by the engineer. In case of columns and walls, the shuttering shall be so adjusted that the vertical drop of concrete in not more than 1.5 meters at a time.

During cold weather, concreting shall not be done when the temperature falls below 4.5° c. the concrete placed shall be protected against frost by suitable converting. Concrete damaged by frost shall be removed and work redone.

During hot weather precaution shall be taken to see that the temperature of wet concrete does not exceed 38°C. no concrete shall be laid within half of the closing time of the day, unless permitted by the engineer.

It is necessary that the time taken between mixing and placing of concrete shall not exceed 30 minutes so that the initial setting process is not interfered with

4.6.4.3 Compaction - Concrete shall be compacted into dense mass immediately after placing by means of mechanical vibrators designed for continuous operations. The engineer may however relax this conditions at his discretion for certain items, depending on the thickness of the members and feasibility of vibrating the same and permit hand compaction instead. Hand compaction shall be done with the help of tamping rods so that concrete is thoroughly compacted and completely worked around the reinforcement, embedded fixtures, and into corners of the form. The layers of concrete shall be so placed that the bottom layer does not finally set before the top layer is placed. The vibrators shall maintain the whole of concrete under treatment in an adequate state of agitation, such that de-aeration and effective compaction is attained at a rate commensurate with the supply of concrete from the mixers. The vibration shall continue during the whole period occupied by placing of concrete, the vibrators being adjusted so that the centre of vibrations approximates to the centre of the mass being compacted at the time of placing.

Concrete shall be judged to be properly compacted, when the mortar fills the spaces between the coarse aggregate and begins to cream up to form an even surface. When this condition has been attained, the vibrator shall be stopped in case of vibrating tables and external vibrators. Needle vibrators shall be withdrawn slowly so as to prevent formation of loose pockets in case of internal vibrators. In case both internal and external vibrators are being used, the internal vibrator shall be first withdrawn slowly after which the external vibrators shall be stopped so that no loose pocket is left in the body of the concrete. The specific instructions of the makers of the particular type of vibrator used shall be strictly complied with. Shaking of reinforcement for the purpose of compaction should be avoided. Compaction shall be completed before the initial setting starts, i.e. within 30 minutes of addition of water to the dry mixture.

4.6.4.4 Construction joints - Concreting shall be carried out continuously up to the construction joints, the position and details of which shall be as shown in structural drawing or as indicated in Fig. 26 or as directed by engineer. Number of such joints shall be kept to minimum. The joints shall be kept at places where the shear force is the minimum. These shall be straight and shall be at right angles to the direction of main reinforcement.

In case of columns the joints shall be horizontal and 10 to 15 cm below the bottom of the beam running into the column head. The portion of the column between the stepping off level and the top of the slab shall be concreted with the beam.

When stopping the concrete on a vertical plane in slabs and beams, an approved stop-board (see Fig.26C) shall be placed with necessary slots for reinforcement bars or any other obstruction to pass the bars freely without bending. The construction joints shall be keyed by providing a triangular or trapezoidal fillet nailed on the stop-board. Inclined or feather joints shall not be permitted. Any concrete flowing through the joints of stop-board shall be removed soon after the initial set. When

concrete is stopped on a horizontal plane, the surface shall be roughened and cleaned after the initial set.

When the work has to be resumed, the joint shall be thoroughly cleaned with wire brush and loose particles removed. A coat of neat cement slurry at the rate of 2.75 kg of cement per square meter shall then be applied on the roughened surface before fresh concrete is laid.

4.6.4.5 Expansion joints - Expansion joints shall be provided as shown in the structural drawings or as indicated in Fig. 10 to 25 or as directed by engineer, for the purpose of general guidance. However it is recommended that structures exceeding 45 m in length shall be divided by one or more expansion joints. The filling of these joints with bitumen filler, bitumen felt or any such material and provision of copper plate, etc. shall be paid for separately in running meter. The measurement shall be taken up to two places of decimal stating the depth and width of joint.

4.6.4.6 Curing - After the concrete has begun to harden i.e. about 1 to 2 hours after its laying, it shall be protected from quick drying by covering with moist gunny bags, sand, canvass Hessian or any other material approved by the engineer. After 24 hours of laying of concrete, the surface shall be cured of ponding with water for a minimum period of 7 days from the date of placing of concrete.

4.6.4.7 Finishing - In case of roof slabs the top surface shall be finished even and smooth with wooden trowel, before the concrete begins to set.

Immediately on removal of forms, the R.C.C work shall be examined by the engineer, before any defects are made good.

- a) The work that has sagged or contains honey combing to an extent detrimental to structural safety or architectural concept shall be rejected as given for visual inspection test.
- b) Surface defects of a minor nature may be accepted. On acceptance of such a work by the engineer, the same shall be rectified as follows -

1) Surface defects which require repair when forms are removed, usually consist of bulges due to movement of forms, ridges at form joints, honey combed areas, damage resulting from the stripping of forms and bolt holes, bulges and ridges are removed by careful chipping or tooling and the surface is then rubbed with a grinding stone. Honey-combed and other defective areas must be chipped out, the edges being cut as straight as possible and perpendicularly to the surface, or preferable slightly undercut to provide a key at the edge of the path.

2) Shallow patches are first treated with a coat of thin grout composed of one part of cement and one part of fine sand and then filled with mortar similar to that used in the concrete. The mortar is placed in layers not more than 10 mm thick and each layer is given a scratch finish to secure bond with the succeeding layer. The last layer is finished to match the surrounding concrete by floating, rubbing or tooling on formed surfaces by pressing the form material against the patch while the mortar is still plastic.

3) Large and deep patches require filling up with concrete held in place by forms. Such patches are reinforced and carefully dowelled to the hardened concrete.

4) Holes left by bolts are filled with mortar carefully packed into places in small amounts. The mortar is mixed as dry as possible, with just enough water so that it will be tightly compacted when forced into

place.

5) Tiered holes extending right through the concrete may be filled with mortar with a pressure gun similar to the gun used for greasing motor cars.

6) Normally, patches appear darker than the surrounding concrete, possibly owing to the presence on their surface of less cement laitance. Where uniform surface colour is important, this defect shall be remedied by adding 10 to 20 percent of white Portland cement to the patching mortar, the exact quantity being determined by trial.

7) The same amount of care to cure the material in the patches should be taken as with the whole structure. Curing must be started as soon as possible, after the patch is finished to prevent early drying. Damp Hessian may be used but in some locations it may be difficult to hold it in place. A membrane curing compound in these cases will be most convenient.

c). The exposed surface of R.C.C work shall be plastered with cement mortar 1 -3 (1 cement - 3 fine sand) of thickness not exceeding 6 mm to give smooth and even surface true to line and form. Any RCC surface which remains permanently exposed to view in the completed structure shall be considered exposed surface for the purpose of this specification.

Where such exposed surface exceeding 0.5 sq.m in each location is not plastered with cement mortar 1:3 (1 cement to 3 fine sand) 6 mm thick, necessary deduction shall be made for plastering not done.

d). The surface which is to receive plaster or where it is to be joined with brick masonry wall, shall be properly roughened immediately after the shuttering is removed, taking care to remove the laitance completely without disturbing the concrete. The roughening shall be done by hacking. Before the surface is plastered, it shall be cleaned and wetted so as to give bond between concrete and plaster.

e). The surface of RCC slab on which the cement concrete of mosaic floor is to be laid shall be roughened with brushes while the concrete is green. This shall be done without disturbing the concrete.

4.6.4.8 Strength of concrete - The compressive strength on work tests for different mixes shall be as given in Table 15 below -

Table 15

Concrete mix (Nominal mix on volume basis)	Compressive strength in (kg/sq cm)	
	7 days	28 days
1:1:2	210	315
1:1 ½ : 3	175	265
1:2:4	140	210

4.6.4.9 Testing of concrete

(1). Regular mandatory tests on the consistency and workability of the fresh concrete shall be done to achieve the specified compressive strength of concrete. These will be of two types

- (a) Mandatory Lab. Test
- (b) Mandatory Field Test

(3). Results of Mandatory Field Test will prevail over Mandatory Lab. Test.

- a) Work Test-Mandatory Lab. Test shall be carried out as prescribed.
- b) Mandatory Field Test (Hammer Test), shall be carried out as prescribe in Annexure 4.A.2
- (4). Additional test - Additional test, if required, shall be carried out as prescribed in Annexure 4.A.7
- (5). Slump test - This test shall be carried out as prescribed in Annexure 4.A.1
- (6). Visual inspection test - The concrete will be inspected after removal of the form work as described. The question of carrying out mandatory test or other tests described in Annexure 4-A.2 and 4-A.4 will arise only after satisfactory report of visual inspection.

The concrete is liable to be rejected, if,

- (i) It is porous or honeycombed.-
- (ii) Its placing has been interrupted without providing a proper construction joint;
- (iii) The reinforcement has been displaced beyond tolerance specified; or construction tolerance has not been met.

However, the hardened concrete may be accepted after carrying out suitable remedial measures to the satisfaction of the engineer at the risk and cost of the contractor.

4.6.4.10 Standard of acceptance

- (1). Mandatory lab test - For concrete sample and tested as prescribed in Annexure 4- A.2 the following requirement shall apply.

Out of six sample cubes, three cubes shall be tested at 7 days and remaining three cubes at 28 days, if found necessary.

(2). 7days' tests

- (a). Sampling - The average of the strength of three specimens shall be accepted as the compressive strength of the concrete provided the variation In strength of individual specimen is not more than $\pm 15\%$ of the average. Difference between the maximum and minimum strength should not exceed 30% of average strength of three specimen. If the difference between maximum and minimum strength exceeds 30% of the average strength, then 28 days' test shall have to be carried out.

- (a). Strength - If the actual average strength of sample accepted in para 'sampling' above is equal to or higher than specified strength up to 15% then strength of the concrete shall be considered in order. In case the actual average strength of sample accepted in the above para is lower than the specified or higher by more than 15% then 28 days' test shall have to be carried out to determine the compressive strength of concrete cubes.

(3). 28 days' test

- (a) The average of the strength of three specimen be accepted as the compressive strength of any individual cube shall neither be less than 70% nor higher than 130% of the specified strength.

- (b) If the actual average strength of accepted sample exceeds specified strength by more than 30%, the engineer, if he so desires may further investigate the matter. However, if the strength of any individual cube exceeds more than 30% of specified strength, it will be restricted to 130% only for computation of strength.

- (c) If the actual average strength of accepted sample is equal to or higher than specified strength upto 30% then strength of the concrete shall be considered in order and the concrete shall be accepted at full rates.

(d) If the actual average strength of accepted sample is less than specified strength but not less than 70% of specified strength, the concrete may be accepted at reduced rate at the discretion of engineer.

(e) If the actual average strength of accepted sample is less than 70% of specified strength, the engineer shall reject the defective portion of work represented by sample and nothing shall be paid for the rejected work. Remedial measures necessary to retain the structure shall be taken at the risk and cost of contractor. If, however, the engineer so desires, he may order additional tests (see Annexure 4-A.4) to be carried out to ascertain if the structure can be retained. All the charges in connection with these additional tests shall be borne by the contractor.

(4). Acceptance criteria of mandatory field test

(A) Preparation of standard test cubes for calibration of rebound hammer at site

(a) In the beginning the standard test cubes of specified mix shall be prepared by field units before undertaking any concrete work in each project.

(b) At least 18 standard cubes necessary for formation of one specimen of specified mix, shall be cast by site staff well in advance. From these 18 cubes any 3 cubes may be selected at random to be tested for crushing strength of 7 days. The crushing strength obtained should satisfy the specified strength for the mix as per specification or agreement. If the strength is satisfactory then the remaining cubes will form the standard samples for calibration of rebound hammer. In case of failure, the site staff should totally reject the samples and remove them also and then make another set of samples by fresh mixing or alternatively, out of the remaining 15 cubes 3 cubes will be tested on 28 days. If the 28 days' tests are found satisfactory then remaining 12 cubes will form the standard sample for calibration at 28 days' strength otherwise all samples shall be rejected and whole procedure repeated to form a fresh specimen. All the results shall be recorded in a register.

(c) No concreting will be allowed unless the standard specimen cubes are obtained.

The criteria for acceptance and calibration of hammer will be 28 days' strength. the 7 days' strength is only to facilitate the work to start.

(d) No work (for the concrete cast between 8th day) shall be allowed to be paid unless 28 days' cube strength is obtained. For the concrete cast between 8th and 28th day, the decision to make the payment may be taken by the engineer on the basis of existing criteria. Concrete work will be rejected if 28 days' strength falls short as per acceptance criteria. No further work will be allowed till the acceptable standard cubes are obtained.

(e) Frequency - It will be once in each quarter or as per the direction and discretion of engineer. Whenever the acceptance criteria is changed or concrete mix or type of cement is changed or engineer feels it necessary for recorded reasons with the approval of the authority according technical sanction, fresh specimen shall be prepared.

(B) Calibration of hammer

(a) Simultaneously, same three cubes to be tested on 28 days as referred in para A (b) above shall be used to correlate the compressive strength of their concrete with rebound number as per procedure described in para 5.2 of the IS: 13311 (Part 2) "Indian standard for non-destructive testing of concrete Method of test by rebound hammer which is given below in para B (b). the average of

values of the rebound number (minimum readings) obtained in respect of same three cubes passing on 28 days' work test shall form the datum reference for remaining cubes for the strength of cubes.

(b) The concrete cubes specimens are held in a compression testing machine under a fixed load, measurements of rebound hammer taken and then compressive strength determined as per IS: 516. The fixed load required is of the order of $7N / mm^2$ when the impact energy of the hammer is about 2.2 NM.

If the specimens are wet cured, they should be removed from wet storage & kept in the laboratory atmosphere for about 24 hours before testing. Only the vertical faces of the cubes as cast should be tested for rebound number. At least nine readings should be taken on each of the three vertical faces accessible in the compression testing machine when using rebound hammers. The points of impact on the specimen must not be nearer than 20 mm from each other. The same points must not be impacted more than once.

(c) The rebound number of hammer will be determined on each of the remaining (18-3-3=12) cubes. Whenever the rebound number of hammer of any individual cube varies by more than $\pm 25\%$ from the datum readings referred to in para B(a) above, that cube will be excluded and will not be considered for standard specimen cubes for calibration. It must be ensured that at least 8 cubes out of 12 that is 66.6% are within the permissible range of variation of rebound number i.e. $\pm 25\%$ or otherwise whole procedure shall have to be repeated and fresh specimen prepared.

These 8 cubes will form one standard sample in the beginning before commencement of work and shall be kept carefully for the visiting officers who will calibrate their hammers on these cubes.

(d) This calibration will be done by field staff with their hammer and then chart of calibration giving the details of the average readings, date & month of casting, mix of the concrete etc. shall be prepared and signed by engineer and will be duly preserved for future reference as and when required.

(C) Preservation of cubes at site - Standard sample cubes cast shall be carefully preserved at site under the safe custody of AE or his representative for making them available together with the charts, to the any other senior departmental officers, during their inspection of the work.

(D) Testing at site - (D-2) Testing will be done generally by non-destructive methods like rebound hammers etc. Each field Division / Sub Division / Unit will purchase rebound hammers and keep them in working order at work site. Testing will be done only by hammers, which are dully calibrated.

(D-3) The relative strength of actual field work will be tested with reference to strength of these standard cubes and calibration charts of a hammer for determining the rebound number on the field work. The hammer will be used as per manufacturer's guidelines at various locations chosen at random. The number of location / reading on each wall, beam or column etc. shall not be less than 12. All the readings should be within the $\pm 25\%$ range of values prescribed in calibration chart normally. However, reading indicating good strength will be when it is at par with calibrated value between 100% & 125% and very good if more than 125%. Any value between 100% & 75% of calibrated value shall be considered satisfactory. Values from 75% to 50% shall be considered for fragment at rates reduced on prorata basis. The concrete indicating rebound number less than 50% of calibrated value shall be rejected and not paid for.

(E) Acceptance of field tests and strength - If the relative strength of actual field work is found satisfactory considering the calibration charts with reference to the standard cube test kept at site, the representative work will be considered satisfactory. If the work is considered below satisfactory, the same will be dealt as stated in para D-3 above.

(F) 7 days' Strength in rare cases only - Normally cube crushing strength on 28 days' test shall form the basis of acceptance. However in rare cases of time bound projects / urgent repairs 7 days' cube test strength criteria may be adopted on similar lines using 7 days' standard test cubes and calibration graphs / curves /charts for 7 days' in lieu of 28 days' and testing work done at 7 days'.

(G) Precautions

(G-1) The testing shall be done generally as per the guidelines of manufacturer of the apparatus and strictly in accordance with the procedure laid down in clause 6 of IS: 13311 (part 2) Indian Standard for Non-Destructive Testing of concrete-Method of Test by Rebound Hammer.

(G-2) The rebound hammers are influenced by number of factors like type of cement aggregate, surface conditions, moisture content, age of concrete etc. Hence care shall be taken to compare the cement, aggregate etc. and tested under the similar surface conditions having more or less same moisture content and age. However effect of age can be ignored for concrete between 3 days & 3 months old.

4.6.4.11 Measurement

4.6.4.11.1. Dimensions shall be measured nearest to a cm except for the thickness of slab which shall be measured correct to 0.5 cm.

4.6.4.11.2. The areas shall be worked out nearest to 0.01 sq. mt. The cubical contents shall be worked out to nearest 0.01 cubic meters.

4.6.4.11.3. Reinforced cement concrete whether cast-in-situ or present shall be classified and measured separately as follows.

(a) Raft, footing, bases of columns etc. and mass concrete. (b) walls (any thickness) including attached pilasters, buttresses, plinth and string course, fillets etc. (c) suspended floors, roofs, landings and balconies. (d) Shelves (e) Chajjas (f) Lintel, beams and Bressummers. (g) Columns, pillars, piers, abutments, posts and struts. (h) Stair-cases including waist or waist less slab but excluding landing except in (l) below. (j) Spiral stair-case (including landing). (k) Arches, arch ribs, domes and vaults. (l) Chimneys and shafts. (m) Well steining. (n) Vertical and horizontal fins individually or forming box, louvers and fascias. (o) Kerbs, steps and the like. (p) String course, bands, coping, bed plates, anchor blocks, plain window sills and the like. (q) Moldings as in cornices window sills etc.

Shell, dome and folded plates. (r) Extra for shuttering in circular work in plan.

4.6.4.11.4 No deduction shall be made for the following -

(a) Ends of dissimilar materials (e.g. joists, beams post girders, rafters, purlin trusses, corbels steps etc.) up to 500 sq cm in cross-section

(b) Opening up to 0.1sq.m.

Note-In calculating area of openings up to 0.1sq.m the size of opening shall include the thickness of any separate lintels or sills. No extra labour for forming such opening or voids shall be paid for.

- (c) The volume occupied by reinforcement.
- (d) The volume occupied by water pipes, conducts etc. not exceeding 25 sq cm each in cross sectional area. Nothing extra shall be paid for leaving and finishing such cavities and holes.

4.6.4.11.5 Measurement shall be taken before any rendering is done in concrete members. Measurement will not include rendering. The measurement of R.C.C. work between various units shall be regulated as below -

- (a) Slabs shall be taken as running continuously through except when slab is monolithic with the beam. In that case it will be from the face to face of the beam.
- (b) Beams shall be measured from face to face of columns and shall include haunches, if any, between columns and beam. The depth of the bottom of beam shall be from the bottom of slab to the bottom of beam and slabs are not monolithic. In case of monolithic construction where slabs are integrally connected with beam, the depth of beam shall be from the top of the slab to the bottom of beam.
- (c) The columns measurement shall be taken through.
- (d) Chajjas along with its bearing on wall shall be measured in cubic meter nearest to two places of decimal. When Chajjas is combined with Lintel, slab or beam, the projecting portion shall be measured as Chajjas, built in bearing shall be measured as per item of Lintel, slab or beam in which chhajja bears.
- (e) Where the band and Lintels are of the same height and the band serves as Lintel, the portion of the band to be measured as lintel shall be for clear length of opening plus twice the over all depth of band.

4.6.4.12. Tolerances - Subject to the condition that structural safety is not impaired and architectural concept does not hamper, the tolerances in dimensions of R.C.C members shall be as specified in the drawing by the designer. Whenever these are not specified, the permissible tolerance shall be decided by the engineer after consultations with the Designer, if necessary.

When tolerances in dimensions are permitted, following procedure for measurements shall apply.

- (a). If the actual dimensions of R.C.C members do not exceed or decrease the design dimensions of the members plus or minus tolerance limit specified above, the design dimensions shall be taken for the purpose of measurements.
- (b). If the actual dimensions exceed the design dimensions by more than the tolerance limit, the design dimensions only shall be measured for the purpose of payment.
- (c). If the actual dimensions decrease more than the tolerance limit specified, the actual dimensions of the RCC members shall be taken for the purpose of measurement and payment.
- (d). For acceptance of RCC members whose dimensions are not exactly as per design dimension of engineer shall be final. For the purpose of payment, however, the clarification as given in para a, b & c above shall apply

4.6.4.13 Rate

The rate includes the cost of materials and labour involved in all the operations described above except for the cost of centering and shuttering.

On the basis of mandatory lab tests, in case of actual average compressive strength being less than

specified strength but upto 70% of specified strength, the rate payable shall be in the same proportion as actual average compressive strength bears to the specified compressive strength.

Example

1. Average compressive strength in 80% of specified strength. Rate payable shall be 80% of agreement rate.
2. In case average compressive strength in less than 70% of the specified strength, the work represented by the sample shall be rejected.
3. However, on the basis of mandatory field test, where they prevail, the rates of the work represented by samples showing actual compressive strength less than specified strength shall be worked out as per para above. In addition, engineer may order for additional tests (see Annexure 4-A.4) to be carried out at the cost of contractor to ascertain if the portion of structure where in concrete represented by the samples has been used, can be retained on the basis of these test. Engineer may take further remedial measures as necessary to retain the structure at the risk and cost of the contractor.

Where throating or plaster drip or molding is not required to be provided in RCC Chajjas, deduction for not providing throating or plaster drip or molding shall be made from the item of R.C.C. In Chajjas. The measurement for deduction item shall be measured in running meters direct to a cm of the edge of chhajja.

No extra payment for richer mix which projects into any meter from another member during concreting of junctions of beams and columns etc. will be made except to the extent structurally considered necessary and when so indicated in the structural drawing. The payments for work done under items of different mixes shall be limited strictly to what is indicated in the structural drawings.

4.6.8. SPECIFICATIONS FOR DESIGN MIX CONCRETE.

Definition - Design mix concrete is that concrete in which the design of mix i.e. the determination of proportions of cement, aggregate & water is arrived as to have target mean strength for specified grade of concrete.

It will be designed based on the principles given in IS 456-2000 and 23 "Hand book for design mix concrete".

In order to ensure that not more than the specification proportion of test results is likely to fall below the characteristic strength, the concrete mix has to be designed for higher average compressive strength for a specified grade of concrete is defined as target mean strength.

4.6.8.1. Materials

Cement - One of the following types of cement as specified shall be used -

1. Ordinary Portland Cement 33 grade conforming to IS: 269.
2. Ordinary Portland Cement 43 grade conforming to IS: 8112.
3. Ordinary Portland Cement 53 grade conforming to IS: 2269.
4. Rapid hardening Portland Cement Conforming to IS: 8041.
5. Blast Furnace slag cement conforming to IS: 455.

However for severe conditions of sulphate content in sub soil water, special literature on use of sulphate resisting cement may be referred to.

Coarse aggregate - This shall be specified in para 4.1.2 and subparas.

Fine aggregate - This shall be grading zone I, II, or III as specified under para 3.1.4 and subparas.

Water - It shall conform to the requirement as laid down in IS: 456 para and para 4.6.1.1. of this section.

Grades of concrete - The compressive strength of various grades of designation concrete shall be as given in table 16 below -

Table 16

Grades designation	Compressive strength on 15 cm cubes min at 7 days (N/mm ²)	Specified characteristic compressive strength at 28 days (N/mm ²)
M 15	10.0	15
M 20	13.5	20
M 25	17.0	25
M 30	20.0	30
M 35	23.5	35

Note - In the designation of a concrete mix letter M refer the mix and the number to the specified characteristic compressive strength of 15 cm-cubes at 28 days expressed in N/mm².

4.6.8.2 Scope - The procedure described below for design mix is for concrete up to grade M-35 which are generally used for reinforced concrete structure. Minimum grade of concrete for design mix will be M-20 normally. However in cases of projects having some parts of M-15 also in addition to M-20 to M-35 grade, then design mix concrete will cover M-15 grade as an exception only.

4.6.8.3 Data for mix design - The following basic data are required to be specified for design of concrete mix.

- (1) Characteristic compressive strength of concrete at 28 days.
- (2) Degree of workability desired.
- (3) Limitation on water cement ratio and minimum cement content to ensure adequate durability.
- (4) Type of maximum size of aggregate to be used.
- (5) Standard deviation of compressive strength of concrete.

Minimum cement content required in Reinforced cement concrete to ensure durability under specified conditions of exposure, will be in accordance with IS: 456. However it shall not be less than 300 Kgs /m³ of concrete for 33 grade cement.

(a). Standard Deviation of concrete for each grade shall depend upon the degree of quality control expected to be exercised at site. As per IS: 10262 the values of standard deviation for various grades of concrete for different degree of control shall be specified in Table. 17.

Table 17

Grade of concrete	Standard Deviation for different degree of control in N/mm ²		
	Very good	Good	Fair

M-15	2.5	3.5	4.5
M-20	3.6	4.6	5.6
M-25	4.3	4.3	6.3
M-30	5.0	6.0	7.0
M-35	5.7	6.7	7.7

Degree of quality control expected under different site conditions are described in Table 18

Table 18

Degree of	Condition of production of concrete
Very good	Fresh cement from single source and regular test, weigh batching of all materials, aggregates grading and moisture content, control of water added, frequent supervision, regular workability and strength tests and field laboratory facilities,
Good	Carefully stored cement and periodic test, weigh batching of all materials, controlled water, graded aggregate supplied, occasional grading and moisture tests, periodic check of workability and strength, intermittent supervision and experienced workers.
Fair	Proper storage of cement, volume batching of all aggregates allowing for bulking of sand, weigh batching of cement, water content controlled by inspection of mix and occasional supervision and tests

4.6.8.4. Target strength for mix design - The target mean strength for a specified grade concrete depends upon the quality control (expressed by standard deviation) and accepted proportion of results of the strength tests below the characteristic strength (F_{ck}) and is given by relation,

$$T_{ck} = f_{ck} + t \cdot s$$

T_{ck} – target mean compressive strength at 28 days

F_{ck} – characteristic compressive strength at 28 days

s – standard Deviation

t – a statistical figure depending upon the accepted proportion of low test results and number of tests.

Note - According to IS: 456 & IS: 1343 the characteristic strength is defined as that value below which not more than 5% (1 in 20) results are expected to fall. In such case value of t will be 1.65 and equation will reduce to $T_{ck} = f_{ck} + 1.65 s$.

Selection of proportions - Since different cement, aggregate, of different maximum size, grading surface texture shape, produce concrete of different compressive strength for the same free water cement ratio, the relationship between strength and free water cement ratio corresponding to 28 days' strength of cement of various grades is given in Fig.1 of IS: 10262 and is reproduced below in chart 1.

28 days strength of cement tested according IS: 4031-1968

A = 31.9 – 36.8 N/mm² (325-375 kg /cm²)

B = 36.8 – 41.7 N/mm² (375-425 kg /cm²)

C = 41.7 – 46.6 N /mm² (425-475 kg /cm²)

D = 46.6 – 51.5 N /mm² (475-525 kg /cm²)

E = 51.5 – 56.4 N/mm² (525-575 kg/cm²)

$F = 56.4 - 61.3 \text{ N/mm}^2$ (575-625 kg/cm²)

Chart 1- Relationship between free water cement ratio and concrete strength for different cement strengths.

(a) The free water cement ratio selected from Chart 1 above should be checked against the limiting water cement ratio for requirement of durability as given in IS: 456 and the lower of the two values is to be adopted.

(b) Estimate of air control - The amount of entrapped air for normal mix (non air entrained) concrete as per IS: 10262 are given in Table 19.

Table 19.

Nominal maximum size of aggregate	Entrapped air as percentage of volume of concrete
10 mm	3.0
20 mm	2.0
40 mm	1.0

(c) Selection of water content and fine to total aggregate ratio - Based on experience, empirical relationship have been established between quantity of water per unit volume of concrete and ratio of fine aggregate to total aggregate by absolute volume for desired workability. The estimated values for concrete up to M35 grade are given in Table 20.

Table 20.

Nominal maximum size of aggregate in mm	Water content in kgs per cubic meter of concrete	Sand as % age of total aggregate by absolute volume
10	208	40
20	186	35
40	165	30

A) The values given in Table 19. are based on the following conditions -

- i) Crushed coarse aggregate conforming to IS: 383 and para 4.1.2 of this specification
- ii) Fine aggregate consisting of natural sand conforming to grading zone II of IS: 383 water cement ratio (by mass) of 0.6 and
- iii) Workability corresponding to compacting factor of 0.8.

B) For other conditions of workability, water cement ratio, grading of fine aggregate and for round aggregate, certain adjustment in quantities of mixing water and fine to total aggregate ratio as given in Table 19 are to be made as per IS: 10262. These are explained in Table 21 below -

Table 21.

Change of conditions stipulated for	Adjustment required in	
	Water content	Percentage of fines to total aggregate

For sand conforming to grading Zone I & III of IS -383	0	+1.5% for Zone I -1.5% for Zone III
Increase or decrease in the value of compacting factor by 0.1 For increase For decrease	+3.0 % -3.0%	0
For each 0.05 increase or decrease in free water-cement ratio For increase For decrease	0 0	+1.0 % -1.0 %
For rounded aggregates	-15 kg / mm ³	-7

C) Comparison of consistency measurement by various methods-

Workability description	Slump mm	Compacting factor
Extremely dry	--	--
Very stiff	--	0.70
Stiff	0-25	0.75
Stiff plastic	25-50	0.85
Plastic	75-100	0.90
Flowing	150-175	0.95

Calculation of aggregate content - With the quantities of water and cement per unit volume of concrete and ratio of fine to total aggregate content per unit volume of concrete to be calculated from the following equations -

$$V = \left\{ w + \frac{C}{S_c} + \frac{1}{p} \times \frac{f_a}{S_{fa}} \right\} \times \frac{1}{1000}$$

$$V = \left\{ w + \frac{C}{S_c} + \frac{1}{1-p} \times \frac{f_a}{S_{ca}} \right\} \times \frac{1}{1000}$$

V = absolute volume of fresh concrete which is equal to gross volume (m³), minus the volume of entrapped air.

W = mass of water (kg) per m³ of concrete

C = mass cement (kg) per m³ of concrete

P = ratio of fine aggregate to total aggregate by absolute volume

S_c = specific gravity of cement

F_a, C_a = aggregate (kg) per m³ of concrete respectively (total masses of fine aggregate and coarse aggregate)

S_{fa}, S_{ca} = Specific gravities of saturated surface dry fine aggregate and coarse aggregate respectively.

Calculation of batch masses - The masses of various ingredients for concrete for design mix of a particular batch size may be calculate as described above.

4.6.8.5 Production of controlled concrete - The calculated mix proportion shall be checked by means of trial batches. Quantities of materials worked out as described above shall be termed as trial mix no.1. The quantities of materials for each trial mix shall be sufficient for at least three 150 mm size cube concrete specimens and concrete required to carry out workability test according to IS: 1199.

Workability of Trial Mix No.1 shall be measured. The mix shall be carefully observed for freedom from segregation and bleeding and its finishing properties. If the measured workability of Trial Mix No.1 is different from the stipulated value, the water content shall be adjusted according to Table 22 corresponding to the required changes in compacting factor. With this adjustment in water content, the mix proportions shall be recalculated keeping the free water-cement ratio at the preselected value which will comprise Trial Mix No.2. In addition, two more Trial Mixes No 3 and 4 shall be made with the water content same as Trial Mix No.2 and varying the free water cement ratio by (+) 10 per cent and (-) 10 per cent of the preselected value. For these two additional trial mixes No.3 and 4, the mix proportions are to be recalculated for the altered condition of free water-cement ratio with suitable adjustments in accordance with Table 22.

Fresh trial mixes are to be made for different types and brands of cement, alternative source of aggregates, maximum size and grading of aggregates.

4.6.8.6. Batching - In proportioning concrete, the quantity of both cement and aggregate should be determined by mass. Cement shall be used on the basis of mass and should be weighed separately from the aggregate. Water should be either measured by volume in calibrated tanks or weighed. Any solid admixture that may be added may be measured by mass. Liquid and paste admixture by volume or mass. Batching plant where used should conform to IS: 4925. All measuring equipment should be maintained in a clean serviceable condition and their accuracy periodically checked.

Except where it can be shown to the satisfaction of engineer that supply of properly graded aggregate of uniform quality can be maintained over the period of work, the grading of aggregate should controlled by obtaining the coarse aggregate in different sizes and blending them in the right proportions when required, the different sizes being stocked in separate stock piles. The material should be stock-piled for several hours preferably a day before use. The grading of coarse and fine aggregate should be checked as frequently as possible, the frequency for a given job being determined by engineer to ensure that the specified grading in maintained.

It is important to maintain the water-cement ratio constant at its correct value. To this end, determination of moisture contents in both fine and coarse aggregate shall be made as frequently as possible, the frequency for a given job being determined by the engineer according to weather conditions. The amount of the water to be added shall be adjusted to compensate for any observed variations in the moisture contents. For the determination of moisture content in the aggregates, IS: 2386 (part 3) may be referred to. The allow for the variation in mass of aggregate due to variation in their moisture content, suitable adjustments in the masses of aggregates shall also be made. In the

absence of exact data, only in the case of nominal mixes, the amount of surface water may be estimated from the values given in the Table 22.

Table 22 (Surface water carried by aggregate) (Clause 4.6.8.4)

Aggregate	Approximate quantity of surface water	
	Percent by mass	Litres/m ³
Very wet sand	7.5	20
Moderately wet sand	5.0	80
Moist sand	2.5	40
Moist gravel to crushed rock	1.25-2.5	20-40

4.6.8.7. Mixing - Concrete shall be mixed in mechanical mixer. The should mixer comply with IS - 1791. It shall be fitted with hopper. The mixing shall be continuous until there is uniform distribution of the material and the mass is uniform in colour and consistency. If there is segregation after unloading from the mixer, the concrete should be remixed. The mixing time shall be not less than 2 minutes.

4.6.8.8. Laying - It shall be done as specified under para 4.2.4 of this specification.

4.6.8.9. Curing - It shall be done as specified under para 4.3.4 of this specification

4.6.8.10. Approval of design mix - The preliminary test for approval of design mix shall consists of three sets of separate tests and each set of test shall be conducted on six specimens. Not more than one set of six specimens shall be made on any particular day. Of the six specimens of each set, three shall be tested at seven days and remaining three at 28 days. The preliminary tests at seven days are intended only to indicate the strength to be attained at 28 days.

4.6.8.11. Work strength test - Work strength test shall be conducted in accordance with IS - 516 on random sampling. Each test shall be conducted on ten specimens, five or which shall be tested at 7 days and remaining five at 28 days. Not less than one work test consisting of testing of test on 10 cubes shall be carried out for every 30 cubic meter of concrete or less as per the lot size as specified below -

Lot size - Concrete under acceptance shall be notionally divided into lots for the purpose of sampling, before commencement of work. The delimitation of lots shall be determined by the following -

No individual lot shall be more than 30 m³ in volume.

- 1) At least one cube forming an item of the sample representing the lot shall be taken from the concrete of same grade and mix proportions cast in any day.
- 2) Different grades or mixes of concrete shall be divided into separate lots.
- 3) Concrete of a lot shall be used in the same identifiable unit of the structure.

4.6.8.12. Standard of acceptance

- a) The average strength of group of cubes cast for each day shall not be less than the specified work cube strength. 20 per cent of cubes cast for each day may have values less than the specified strength provided that the lowest value is not less than 85% of the specified strength.
- b) Concrete strength less than specified may as a special case be accepted in a member with the approval of engineer provided that the maximum stress in the member under the maximum

design live load does not exceed the permissible safe stress appropriate to the lower strength of the concrete.

- c) Concrete which does not meet the strength requirements as specified but has a strength greater than that of the lowest value of 85% may, at the discretion of the designer, be accepted as being structurally adequate without further testing.
- d) Concrete of each grade shall be assessed separately.
- e) Concrete shall be assessed daily for compliance.
- f) Concrete is liable to be rejected if it is porous or honey combed, its placing has been interrupted without providing a proper construction joint, the reinforcement has been displaced beyond the tolerances specified, or construction tolerances have not been met. However, the hardened concrete may be accepted after carrying out suitable remedial measures to the satisfaction of the engineer.

4.6.8.13. An example illustration the mix design for concrete mix M 20 grade is given below -

Design stipulation

a	Characteristic compressive strength required in the field at 28 days	20N/mm ²
b	Maximum sizes of aggregate	20 MM (angular crushed)
c	Degree of workability	0.9 compacting factor (slump 75 mm)
d	Degree of quality control	Good
e	Type of exposure	Mild

Test data of material

a	Cement used - ordinary Portland cement satisfying the requirements of IS: 269-1989	
b	Specific gravity of cement	3.15
c	Specific gravity of	
i)	Coarse aggregate	2.60
ii)	Fine aggregate (natural sand)	2.60
d	Water absorption of	
i)	Coarse aggregate	0.5 percent
ii)	Fine aggregate (natural sand)	1.0 percent
e	Free surface moisture of	
i)	Coarse aggregate	Nil (absorbed moisture also nil)
ii)	Fine aggregate (natural sand)	2.0 percent

Sieve analysis

a) Coarse aggregate

IS sieve Size mm	Analysis of course aggregate fraction (Percent passing)		Percentage of different fraction		
			I	II	Combined
20	100	100	60%	40%	100%

10	0	71.2	60%	40%	100%
4.75		9.4	0	28.5%	28.5%
2.63		0		3.7%	3.7%

The grading of combined fraction I and II in the ratio of 60 and 40 conform to Table 10 described above.

b) Fine aggregate

IS sieve sizes	Fine aggregate (percent passing)
100	-
2.36 mm	100
1.18 mm	93
600 micron	60
300 micron	12
150 micron	2

The sand conforms to grading zone III.

Target mean strength - As described earlier for degree of quality control 'good' the value of standard deviation is 4.6, therefore with a tolerance factor of 1.65 the value of target mean strength for specified characteristic cube strength = $20 + 1.65 \times 4.6 = 27.6 \text{ N/mm}^2$.

Selection of water cement ratio - From chart 1, the free water cement ratio required for target mean strength of 27.6 N/mm^2 is 0.50. This is lower than the maximum value of 0.65 prescribed for mild exposure.

Selection of water and sand content - From Table 8 for 20 mm nominal maximum size aggregate and sand conforming to grading zone II water content as per cum concrete is 186 kg and sand content percentage of total aggregate by absolute volume is equal to 35%. For change in value of water cement ratio compacting factor, and sand belonging to zone III the following adjustment is required.

Change in condition	Adjustment required in	
	Water content	Percentage in total aggregate
For decrease in water cement Ratio by (0.6-0.5) i.e.0.10	0	-2
For increase in compacting Factor by (0.9-0.8) I.e. 0.10	+3	0
For the conforming Grading zone III	0	-1.5
Total	3	-3.5

Therefore, the required water content = $186 + 186/100 \times 3 = 186 + 3.58 = 191.6 \text{ kg / m}^3$

And required sand content = $35 - 3.5 = 31.5 \text{ percent}$

Determination of Cement Content

Water-Cement ratio = 0.5

Water = 191.6 kgs

Cement = $191.6 / 0.5 = 383 \text{ kg / m}^3$

Thus cement content is adequate for mild exposure condition as per IS: 456-2000 as described in table below.

Determination of coarse and fine aggregate content

From Table 18 for specified maximum size of aggregate of 20 mm, the amount of entrapped air in wet concrete is 2 per cent. Taking this into account and applying equations given above.

$$0.98 \text{ m}^3 = 191.6 + 383/3.15 + 1/0.315 \cdot f_a / 2.60 \times 1 / 1000$$

and

$$0.98 \text{ m}^3 = 191.6 + 383/3.15 + 1/0.315 \cdot C_a / 2.60 \times 1 / 1000$$

or $f_a = 546 \text{ kg / m}^3$ and $C_a = 1187 \text{ kg / m}^3$

The mix proportion now works out -

Water	Cement	Fine aggregate	Coarse aggregate
191.6	383 kg	546 kg	1187 kg
or 0.5	1	1.42	3.0

For 50 kg cement, the quantity of materials are worked out as below -

a)	Cement	= 50 kg.
b)	Sand	= 71 kg
c)	Coarse aggregate	154.5 kg.
	Fraction I - 92.7	
	Fraction II - 61.8	
d)	Water	
1	For water cement ratio of 0.5 quantity	= 25.0 kg.
2	Extra quantity of water to be added for absorption in coarse aggregate at 0.5% by mass	= $154.5 / 100 \times 0.5 = 0.77 \text{ kg.}$
3	Quantity of water to be deducted for free moisture in sand at 2% by mass	= $(-) 171.0 / 100 \times 2 = (-) 1.42 \text{ kg.}$

Therefore actual quantity of water = $25.00 + 0.77 - 1.42 = 24.35 \text{ kg}$

Actual quantity of sand required after allowing for mass of free moisture

$$= 71.0 + 1.42 = 72.42 \text{ kg}$$

Actual quantity of Coarse aggregate

$$\text{Fraction I} = 92.7 - (0.6 \times 0.77) = 92.24$$

$$\text{Fraction II} = 61.8 - (0.4 \times 0.77) = 61.49$$

Therefore the actual quantities of different constituent required for mix are -

Water = 24.35 kg

Cement = 50 kg

Sand = 72.42 kg

Coarse aggregate Fraction I = 92.42 kg Fraction II = 61.49 kg

Measurements shall be done in accordance with paras above.

Tolerances - Paras above shall apply.

Rate – Paras above shall apply with the exception regarding limitations for actual average compressive strength being less than specified strength which shall be governed by para above for acceptance and prorata rates worked out accordingly.

Annexure **4–A.1**

SLUMP TEST

Apparatus - Mould shall consist of a metal frustum of cone having the following internal dimensions -

Bottom diameter20 cm

Top diameter10 cm

Height30 cm

The mould shall be of a metal other than brass and aluminum of at least 1.6 mm (or 16 BG) thickness. The top and bottom shall be open and at right angles to the axis of the cone. The mould shall have a smooth internal surface. It shall be provided with suitable foot pieces and handles to facilitate lifting it from the moulded concrete test specimen in a vertical direction as required by the test. A mould provided with a suitable guide attachment may be used.

Tamping rod shall be of steel or other suitable material 16 mm in diameter 60 mm long and rounded at one end.

Procedure - The internal surface of the mould shall be thoroughly cleaned and free from superfluous moisture and any set concrete before commencing the test. The mould shall be placed on a smooth horizontal, rigid and non-absorbent surface viz. leveled metal plate. The operator shall hold the mould firmly in place while it is being filled with test specimen of concrete. The mould shall be filled in four layers, each approximately one quarter of height of

mould. Each layer shall be tamped with twenty-five strokes of the rounded end of the tamping rod. The strokes shall be distributed in a uniform manner over the cross section of the mould and for the second and subsequent layers shall penetrate into the underlying layer. The bottom layer shall be tamped through out its depth, after the top layer has been rodded, the concrete shall be struck off level with trowel or the tamping rod, so that the mould be exactly filled. Any mortar, which shall leak out between the mould and the base plate, shall be cleaned away. The mould shall be removed from the concrete immediately after filling by raising it slowly and carefully in a vertical direction. The molded concrete shall then be allowed to subside and the slump shall be measured immediately by determining the difference between the height of the mould and that of the highest point of specimen.

The above operations shall be carried out at a place free from vibration or shock, and within a period of two minutes after sampling.

Result - The slump shall be recorded in terms of millimeters of subsidence of the specimen during the test. Any slump specimen which collapses or shears off laterally gives incorrect result. If this occurs, the test shall be repeated with another sample.

The slump test shall not be used for very dry mixes as the results obtained are not accurate.

Annexure 4-A.2

WORK TEST FOR CONCRETE – MANDATORY LAB TEST

A-O One sample (consisting of six cubes 15x15x15 cm shall be taken for every 20 cum or part thereof at concrete work ignoring any part less than 5 cum or as often as considered necessary by the engineer. The test of concrete cubes shall be carried out in accordance with the procedure as described below. A register of cubes shall be maintained at the site of work in Annexure 4-A.8. The casting of cubes and all other incidental charges, such as curing, carriage to the testing laboratory shall be borne by the contractors. The testing fee for the cubes, if any, shall be borne by the department.

A-1 Test procedure

A-1.1 Mould - The mould shall be of size 15 cm x 15 cm x15 cm for the maximum nominal size of aggregate not exceeding 40 mm. For concrete with aggregate size more than 40 mm, size of mould shall be specified by the engineer keeping in view the fact that the length of size of mould should be about four times the size of aggregate

The moulds for test specimens shall be made of non-absorbent material and shall be substantially strong enough to hold their form during the moulding of test specimens. They shall not vary from the standard dimensions by more than one per cent. The moulds shall be so constructed that there is no leakage of water from the test specimen during moulding. All the cube moulds for particular site should, prior to use, be checked for accuracy in dimensions and geometric form and such test should at least be made once a year.

Each mould shall be provided with a base plate having a plane surface and made of non-absorbent material. This plate shall be large enough in diameter to support the moulds properly without leakage. Glass plates not less than 6.5-mm thick or plain metal not less than 12 mm thick shall be used for this purpose. A similar plate shall be provided for covering the top surface of the test specimen when molded.

Note - Satisfactory moulds can be made from machine or steel castings, rolled metal plates or galvanized iron.

A-1.2 Sample of concrete - Samples of concrete for test specimen shall be taken at the mixer or in the case of ready mixed concrete from the transportation vehicle discharge or as directed by engineer. Such samples shall be obtained by repeatedly passing a scoop or pail through the discharge stream of concrete. The sampling operation should spread over evenly to the entire discharging operation. The samples thus obtained shall be transported to the place of molding of the specimen. To counteract segregation, the concrete shall be mixed with a shovel until it is uniform in appearance. The location in the work of the batch of concrete thus sampled shall be noted for further reference. In case of paving concrete, samples shall be taken from the batch immediately after deposition of the sub grade. At least five samples shall be taken from different portion of the pile and these samples shall be spread as evenly as possible throughout the day. When wide changes occur during concreting, additional samples shall be taken if so desired by the engineer.

A-1.3 Preparation of test specimens - The interior surfaces of the mould and base plate shall be lightly oiled before the concrete is placed in the mould. The samples of concrete obtained as described

under the test specimen shall be immediately molded by one of the following methods as indicated below.

When the job concrete is compacted by manual methods, the test specimen shall be molded by placing, the fresh concrete in the mould in three layers, each approximately one-third of the volume of the mould. In placing each scoopful of concrete the scoop shall be moved around the top edge of the mould as the concrete there slides from it, in order to ensure a uniform distribution of concrete within the mould. Each layer shall be rodded 35 times with 16 mm rod, 60 cm in length, bullet pointed at the lower end. The strokes shall be distributed in uniform manner over the cross section of the mould and shall penetrate into underlying layer. The bottom layer shall be rodded throughout its depth. After the top layer has been struck off with a trowel and covered with a glass plate at least 6.5 mm thick or a machined plate. The whole process of molding shall be carried out in such a manner as to preclude the change of the water cement ratio of the concrete, by loss of water either by leakage from the bottom or over flow from the top of mould,

When the job concrete is placed by vibration and the consistency of the concrete is such that the test specimens cannot be properly molded by hand rodding as described above, the specimens shall be vibrated to give a compaction corresponding to that of the job concrete. The fresh concrete shall be placed in mould in two layers, each approximately half the volume of the mould. In placing each scoopful of concrete the scoop shall be moved around the top edge of the mould as the concrete there slides from it, in order to ensure a symmetrical distribution of concrete within the mould. Either internal or external vibrator may be used. The vibration of each layer shall not be continued longer than is necessary to secure the required density. Internal vibrators shall be of appropriate size and shall penetrate only the layer to be compacted. In compacting the first layer, the mould shall be filled to the extent that there will be no mortar loss during vibration. After vibrating the second layer enough concrete shall be added to bring level above the top of the mould. The surface of the concrete shall then be struck off with a trowel and covered with a glass or steel plate as specified above. The whole process of molding shall be carried out in such a manner as to preclude the alteration of water cement ratio of the concrete by loss of water, either by leakage from the bottom or over flow from the top of the mould.

A-1.4 Curing and storage of test specimen - In order to ensure reasonably uniform temperature and moisture conditions during the first 24 hours for curing the specimen and to protect them from damage, moulds shall be covered with wet straw or gunny sacking and placed in a storage box so constructed and kept on the work site that its air temperature when containing concrete specimens shall remain 22° C to 33° C. Other suitable means which provide such a temperate and moisture conditions may be used.

Note - It is suggested that the storage box be made of 25 mm dressed tongued and grooved timber, well braced with battens to avoid warping. The box should be well painted inside and should be provided with a hinged cover and padlock.

The test specimen shall be removed from the moulds at the end of 24 hours and stored in a moist condition at a temperature within 24° C to 30° C until the time of test. If storage in water is desired, saturated lime solution shall be used.

A-1.5. Testing - The specimens shall be tested in accordance with procedure as described below -

The tests shall be made at an age of concrete corresponding to that for which the strengths are specified.

Compression tests shall be made immediately upon removal of the concrete test specimen from the curing room i.e. the test specimen shall be loaded in damp condition. The dimensions of the test specimens shall be measured in mm accurate to 0.5 mm.

The metal bearing plates of the testing machine shall be placed in contact with the ends of the test specimens. Cushioning materials shall not be used. In the case of cubes, the test specimen shall be placed in the machine in such a manner that the load is applied to sides of the specimens as cast. An adjustable bearing block shall be used to transmit the load to the test specimen. The size of the bearing block shall be the same or slightly larger than that of test specimen. The upper or lower section of the bearing block shall be kept in motion as the head of the testing machine is brought to a bearing on the test specimen.

The load shall be applied axially without shock at the rate of approximately 140 kg. sq cm per minute. The total load indicated by the testing machine at failure of test specimen shall be recorded and the unit compressive strength is calculated in kg per sq cm using the area computed from the measured dimensions of the test specimen. The type of failure and appearance of the concrete shall be noted.

Annexure 4-A.3.

REBOUND HAMMER TEST. (MANDATORY FIELD TEST)

If a rebound hammer is regularly used by trained personnel in accordance with procedure described in IS: 13311 (part II) and a continuously maintained individual charts are kept showing a large number of readings and the relation between the readings and strength of concrete cubes made from the same batch of concrete, such charts may be used in conjunction with hammer readings to obtain an approximate indication of the strength of concrete in a structure or element. If calibration charts are available from manufacturers, it can be used. When making rebound hammer tests each result should be the average of at least 12 readings. Readings should not be taken within 20 mm of the edge of concrete members and it may be necessary to distinguish between readings taken on a troweled face and those on a molded face, when making the test on a precast units, special care should be taken to bed them firmly against the impact of the hammer.

Annexure 4-A.4

ADDITIONAL TESTS FOR CONCRETE

C-0 In case the concrete fails when tested as per the method prescribed in Annexure 4-A.5, one or more of the following check tests may be carried out at the discretion of engineer to satisfy the strength of the concrete laid. All testing expenditure shall be borne by the contractor. The number of additional tests to be carried out shall be determined by the engineer. He shall be the final authority for interpreting the results of additional tests and shall decide upon the acceptance or otherwise. His

decision in this regard shall be final and binding. For the purpose of payment, the Hammering test results only shall be the criteria. Some of the tests are outlined below -

C-1 Cutting cores - This method involves drilling and testing cores from the concrete for determination of compressive strength. In suitable circumstances the compressive strength of the concrete in the structure may be assessed by drilling cores from the concrete and testing. The procedure used shall comply with the requirements of IS: 1199 and IS: 516.

The points from which cores shall be taken shall be representative of the whole concrete and at least three cores shall be obtained and tested. If the average of the strength of all cores cut from the structure is less than the specified strength, the concrete represented by the cores shall be liable to rejection and shall be rejected if a static load test (C-4) either cannot be carried out or is not permitted by the engineer.

C-2 Ultrasonic test - If an ultrasonic apparatus is regularly used by trained personnel in accordance with IS: 13311 (part I) and continuously maintained individual charts are kept showing a large number of readings and the relation between number of readings and the relation between the reading and strength of cubes made from the same batch of concrete, such charts may be used to obtain approximate indications of the strength of concrete in the structures. In cases of suspected lack of compaction or low cubes strength the results obtained from the ultrasonic test results on adjacent acceptable sections of the structures may be used for the purpose of assessing the strength of concrete in the suspected portion.

C-3 Load Tests on Individual Precast Units - The load tests described in this clause are intended as a check on the quality of the units and should not be used as a substitute for normal design procedures. Where members require special testing, such special testing procedures shall be in accordance with the specification. Test loads shall be applied and removed incrementally.

C-3.1. Non-destructive tests - The unit shall be supported at its designed points of support and loaded for five minutes with a load equal to the sum of the characteristic dead load plus one and a quarter times the characteristic imposed load. The deflection is then recorded. The maximum deflection after application of the load shall be in accordance with the requirements defined by the engineer. The recovery is measured five minutes after the removal of the load and the load then reimposed. The percentage recovery after the second loading shall be not less than that after the first loading nor less than 90% of the deflection recorded during the second loading.

At no time during the tests, shall the unit show any sign of weakness or faulty construction as defined by the engineer in the light of reasonable interpretation of relevant data.

C-3.2. Destructive tests - The unit is loaded while supported at its design point of support and must not fail at its design load for collapse, within 15 minutes of time when the test load becomes operative. A deflection exceeding 1/40 of the test span is regarded as failure of the unit.

C-3.3. Special tests - For very large units or units not readily amenable to the above tests e.g. columns, the precast parts of composite beams and members designed for continuity or fixity, and the testing arrangement shall be agreed upon before such units are cast.

C-4. Load tests of structures or parts of structures - The tests described in this clause are intended as check where there is a doubt regarding structural strength. Test loads are to be applied and removed incrementally.

C-4.1. Age at tests - The test is to be carried as soon as possible after the expiry of 28 days from the time of placing of the concrete. When the test is for a reason other than the quality of concrete in the structure being in doubt, the test may be carried out earlier, provided that the concrete has already reached its specified characteristic strength.

C-4.2. Test load - The test loads to be applied for the limit states of deflection and local damage are the appropriate design loads i.e. the characteristic dead and superimposed loads. When the limit state of collapse is being considered the test load shall be equal to the sum of characteristic dead load plus one and a quarter times the characteristic imposed load and shall be maintained for a period of 24 hours. In any of the test temporary supports of sufficient strength to take the whole load shall be placed in position underneath but not in contact with the member being tested. Sufficient precautions must be taken to safeguard persons in the vicinity of the structure.

C-4.3. Measurements during tests - Measurements of deflection and crack width shall be taken immediately after application of the load and, in the case of 24h loaded period, after removal of the load and after 24h recovery period. Sufficient measurements shall be taken to enable side effects to be taken into account. Temperature and weather conditions shall be recorded during the tests.

C-4.0. Assessment of results - In assessing the strength of a structure or a part of the structure following a load test, the possible effects of variation in temperature and humidity during the period of the test shall be considered.

The following requirements shall be met -

The maximum width of any crack measured immediately on application of the test load for local damage, is to be not more than $2/3$ of the value of the appropriate limit state requirement.

For members spanning between two supports the deflection measured immediately on application of the test load for deflection is to be not more than $1/500$ of the effective span. Limits shall be agreed upon before testing cantilevered portions of structures.

If maximum deflection in mm shown during 24 h under load is less than $40 L^2 / DD$ where L is effective span in m and D is overall depth of construction in mm, it is not necessary for the recovery to be measured and the requirements (d) does not apply, and

If within 24 hours of the removal of test load for collapse as calculated in clause (a) a reinforced concrete structure does not show a recovery of at least 75 per cent of the maximum deflection shown during the 24 h under load, the loading should be repeated. The structure should be considered to have failed to pass the test if the recovery after second loading is not at least 75 per cent of the maximum deflection shown during the second loading.

Annexure 4-A.5

FORMWORK AND SCAFFOLDING

1. Concrete is the most widely used construction material today because of its durability, mouldability and other characteristic. Concrete in its plastic stage has no form and therefore, needs to be molded to the required shape. Formwork includes the mould in contact with the wet concrete and

all the necessary supports, hardware and bracing. The hardware supports and bracings are generally referred to as centering or false work. Scaffolding is the structure made to provide access to the point of working.

2. In the early days, formwork was generally rigged up by carpenter with available timber and nails as best as possible, using rule of thumb approach. Along with the growth in the development of concrete construction, formwork techniques have also developed side by side. With the technological advancement and introduction of new materials such as plywood, steel, aluminium, polypropylene, fibre reinforced plastics etc more rational approach is being made in the design of formwork.

3. Formwork - The basic objectives of the formwork designer should be to achieve the following:

4. Safety: to build substantially so that formwork is capable of supporting all dead and live loads, without collapse or danger to workmen and to the concrete structure.

5. Quality: To design and build forms accurately so that the desired size, shape and finish of the concrete is attained.

6. Economy: To build efficiently saving time and money for the contractor and owner.

7. Safety must find the first place in the design, construction, erection and stripping of formwork and centering systems.

8. Design consideration - To achieve the above basic objectives of formwork design the following should be considered.

a) Correct assessment of loads that come over forms with due consideration to pressures that arise from wet concrete.

b) Selection of proper forming material considering its strength, durability and cost.

c) Selection of proper supporting systems, either of wood, steel or aluminium. Proprietary supporting systems that are standardized and proved by tests should be adopted with advantage.

d) Provision for proper ties/anchors for the forms and bracing for support.

e) Provision of proper and safe working/access platforms for labour and equipment.

f) Proper scheduling, stripping and refixing of shores.

It is important to realize that centering design requires the same skill and attention to details as the design of permanent structure of like type.

9. Loads on forms - The loads on vertical forms are to be assessed from consideration of:

a. Density of concrete, b. Slump of concrete, c. Rate of pour, d. Method of discharge, e. Concrete temperature, f. Vibration, g. Height of discharge, h. Dimensions of section cast, i. Reinforcement details, j. Stiffness of forms

10. Form material and type - The choice of the form material mainly depends on the availability and cost of the material. Form materials include timber, plywood, hardboard, plastic fiber board, corrugated boxes, steel, aluminium, plaster of Paris etc., Thin metal sheets, neoprene craft paper, hardboard, fibre board and gypsum are generally used as forms liners attached to inside face to improve or alter the surface texture of concrete. Timber, plywood and steel are the main materials used in our country.

11. Timber - Traditional material for formwork has been timber due to its easy availability, relatively low cost and ease for shaping. The disadvantages of timber are warping, twisting, deterioration under

stress of heat and contact with wet concrete. It is common practice to support formwork for slab in buildings with timber ballies cut to approximate sizes with wedges used underneath them for final adjustments. These make weak points and are seldom prevented from displacement. Timber ballies are generally not straight and do not transmit load axially.

12. Plywood - The advantages of plywood are large panels for economical construction and removal, choice of thickness, physical properties, good finish and economy from repeated uses.

13. Steel - Steel has been an important material for fabrication of standard as well as special purpose forms, accessories and hardware. Steel is also extensively used for making horizontal and vertical shores. Because of the known characteristics of steel, design calculations for the system can be precisely made. Steel formwork system also facilitates to maintain accurate alignment, level and dimension with excellent surface finish.

Readymade forms are modular panel systems and accessories that can be adopted to build formwork for various sizes and shapes. Tailor made or special purpose made forms is fabricated to order and include tunnel forms, bridge girder shutters, dam shutters etc.

14. Climbing formwork - Most commonly used formwork system is the Climbing Forms. This system basically consists of form panels assembled with or without walers and supported by vertical strong back members (generally called soldiers) of various designs. The Climbing Form System for large and deep concrete pours may incorporate special features such as, working platforms, adjustable push-pull struts for aligning the formwork and also roller mechanism for shifting the form assembly to allow tying reinforcement and fixing other inserts, in case of thin walls. Various types of anchorage's are used to fix or support the Climbing Form Assembly to the previous concrete lift complete floor height in case of shear walls in buildings, deep pours in piers, abutments of bridges and duct walls are typical examples where such systems are used and generally handled by cranes. For smaller structures and shallow pours, lighter soldiers are used and the Form assembly is usually dismantled in small sections and refixed from pour to pour manually, with external access scaffolding.

15. Slip forms - Slip form construction also known, as sliding forms of construction is similar to extrusion process. The rate of movement of forms is regulated so that when forms leave the concrete it is strong enough to retain its shape while supporting its own weight. Vertical slip form is used for bins, soils, bridge piers etc. whereas horizontal slip form is used for canal lining, tunnel inverts etc. Recent developments in slip form techniques enable construction of tapered structures like chimneys, cooling towers etc where simultaneously with moving of forms, vertically, mechanical/hydraulic jacks also adjust the forms circumferentially to the required sizes as the slide progresses.

16. Suspended forms - This is a climbing system of formwork used for construction of chimneys, silos etc. the forms for outside of the structure is suspended from a concreting platform which in turn is suspended from a central scaffold tower by means of chain pulley block. The formwork system incorporates a radial shift mechanism for adjusting the outer form to the required diameter. The inside forms are usually the climbing types.

17. Travelling or moving forms - Travelling or moving forms are usually made of steel and are generally resorted for construction of long stretches of similar section such as tunnel linings, sewers, galleries, culverts etc. Substantial saving in time and labour is possible by using travelling forms.

Travelling forms are tailors made form fabricated/assembled to shape and supported by framework or gantry structure which is fitted with wheels for movement either manually or by electric or hydraulic motors. Hinges or other stripping devices are provided in the shutter itself for collapsing the formwork by means of jacks or turnbuckles. In telescopic type the form is so designed that with one mobile gantry several units of formwork can be handled by telescoping one section of formwork through the other.

18. Aluminum forms - Certain aluminium alloys are used for making forms, which are similar to steel forms. They are lightweight and reduce handling costs.

19. Concrete hardware's - Formwork systems generally incorporate a variety of hardware's such as ties and anchors for resisting lateral pressure exerted by green concrete. Form ties are tensile units consisting of an internal tension member and an external holding device. The ties can be continuous single unit or internal disconnecting type. Form anchors are devices embedded in previously poured concrete and are used for securing formwork for the subsequent lifts.

20. Formwork supports or centering - Various types of formwork supports have been developed in steel. They have been specially designed to cut labour cost in erection and stripping and to make them versatile by incorporating an adjustability feature in most cases. Generally formwork supports are either single leg type or multilegged type such as a frame or a tripod or a trestle. The single leg type is called a prop or a shore and is generally tubular and telescopic type. It incorporates adjusting features through a collar or nut to provide infinite adjustment in height. The props are usually used for supporting formwork upto heights of about 5 M. Beyond this height, they may be used in tiers in which case they are properly tied and braced to form a rigid structure. Bracings can be provided by means of tubes and clamps.

Among the multilegged support systems the common ones are of prefabricated tubular frames in a variety of shapes and modular sizes which can be assembled one over other to get the required heights and also spaced at suitable intervals depending on the loads to be carried. The forms are usually braced together by means of ledgers and cross braces to form a rigid structure. For finer adjustments in height, there are special accessories like screw jack either at top or bottom or both.

Like vertical formwork supports or shores there are also many types of horizontal formwork supports available. These are usually latticed or boxed beams which also telescope one into the other and cater for a range of spans. These horizontal supports rest either on beam forms or other shores at ends. The need for intermediate supports is eliminated and free access and working space is obtained during construction.

An important development in the formwork system particularly for flat slab and multistoried construction is the drop head system. Drop head is fitted on top of the prop or supports which continue to support the slab while the remaining form for the decking could be struck for reuse, there by affecting a great economy in the formwork costs. With this system only an extra set of shores would be required to get faster cycle of slab construction.

Various scaffolding systems may also be adopted and used to act as centering especially when the heights of supports involved is large such as in the case of high industrial buildings, motorway decks, high shell or barrel roof hangers etc.

21. Scaffolding - Practically in all stages of construction, scaffolds are required to provide temporary platforms at various levels to carry out all these works which can not be conveniently and easily carried out either from ground level or any other floor of the building or with the use of a ladder.

22. Timber scaffold - Timber has been used for building scaffold from time immemorial and continues to be used even today. The most common type of scaffolding used in India even today is bally or bamboo scaffold. Barring a few cases where bally or bamboo scaffolding is neatly erected, properly braced and well tied to the building, invariably such scaffolds are in crooked and awkward shapes presenting a dreadful sight particularly on tall building where a stronger and safer scaffolding is called for. The draft revision of IS 3696 suggests limiting bamboo and timber scaffold up to maximum of 18 M. height.

23. Metal scaffold - By and large metal scaffolds are made of steel tubes. Many countries have formulated standard specifications and codes of practice for metal scaffolding. IS: 2750 for steel scaffolding and IS: 4014 parts 1 and 2 for steel tubular scaffolding are relevant Indian Standards.

Metal scaffolds are broadly two types viz. Tubes and fitting type and prefabricated unit frame type.

Tubes and fittings type consists of plain tubes, which are, used for making uprights, transoms, ledger and putlog. Various type of clamps viz. Right angle or double coupler, swivel coupler, putlog coupler, joint pins etc are available for connecting tubes.

Many designs of prefabricated unit type of scaffold have been developed by proprietary concerns and are now being extensively used in most of the construction sites through out the world. Units have been designed incorporating the following basic features.

- i) Prefabrication of adjustable components with few or no loose parts.
- ii) Simple and fool-proof devices as far as practical to ensure maximum safety.
- iii) Speed and ease in erection and dismantling at site by unskilled workers.
- iv) Known characteristics of each component enabling complete calculation of loading to ensure use of minimum materials.
- v) High degree of versatility and durability enables hundreds of uses for a wide range of applications.

Some of the prefabricated types of scaffoldings available are as follows:

24. Unit frame or three pieces frame - This consists of two verticals and one horizontal member with specially designed end fittings and when three are assembled together it forms a H frame. The end fittings on the horizontal also incorporate a fixing device for the longitudinal ledger. The unit frames can be erected one above the other and are spaced at suitable intervals depending on the duty of the scaffolding. The manufacturers provide complete data on loading capacities. The advantage of this type of three piece frame is that the units can be spaced at any required intervals and also the platforms can be had at any required levels and hence scaffold of this type may be truly called as all purpose type.

25. Welded frame type - These scaffold frames are made as welded units consisting of two uprights and one or more cross members to form a rectangular or H frame. Such frames can be erected one over the other to the required height. Lengthwise such frames are connected either by scissors type cross braces or ledgers. In this system the length of the ledger or cross braces decides the longitudinal spacing of the frame. Accessories such as base plate, adjustable stirrup head etc are

also supplied to complete the system. The frames are made of tubes in different grades viz. Light duty or heavy duty as required.

26. Wedge lock or collar grip type - Wedge lock type scaffold consists of verticals, ledgers, transoms and diagonals. The uprights have housing welded on them at regular intervals. The transoms, ledgers and diagonals have specially designed wedge lock assemblies fitted at ends, which engage in the housing on the uprights. This type of scaffolding can be erected very fast and does not require any special tool except a small hammer to drive the wedges in. Necessary accessories are also supplied to complete the system. This is extensively used for building scaffold towers inside chimneys, silos etc and also in ship building.

29. Scaffold boards - Scaffold boards for platform are generally in timber, particularly in pinewood because of its lightweight and strength. Apart from timber boards, Steel planks are also available. They are generally made with thin M.S. Sheet with pressed or cold-formed flanges and provided with anti-skid surface treatment. It may be noted that steel planks would not be suitable for platform in extreme tropical climate and also where oil/grease or such other slippery materials are likely to fall on platforms.

30. Safety requirements - Codes of practice specify the construction details of scaffolding and also give guidelines for bracketing and tying of scaffolds for stability. Single pole scaffolds shall be braced longitudinally and the double pole scaffold shall be braced both longitudinally and transversally, so that the scaffolds form a rigid and stable structure. The scaffold shall be effectively tied to a building or adjacent structure to prevent movement of the scaffold either towards or away from the building or structure. In extreme wind conditions, it may be necessary to provide additional ties, guys or other suitable supports as decided by the engineer.

31. Scaffolding systems.

1. Metallic scaffolding is mainly of steel although aluminum is also finding increasing use as a raw material. Steel scaffolding generally includes the following.

2. Tubes & fittings. This is the commonest type of metallic scaffold first used in 1908 by a British company. This system is versatile but cumbersome and time-consuming to use since it involves a lot of joints and several loose components, which necessitate safety precautions during erection. It is recommended only for limited applications such as access scaffold for not a very tall building and for old structures/connections.

3. Welded frame-Type-Fabricated - Steel frames and cross braces systems frames are placed at regular intervals one over the other and inter-connected by cross braces for rigidity and stability. This is sturdier and safer, easy to erect and dismantle, and is suited for most staging and scaffolding jobs. But the system has some limitations in use due to the fixed size of components. It is ideal for access scaffold, heavy staging of industrial buildings, bridges, flyovers, aqueducts, etc.

4. All-purpose units / Wedge-lock type scaffolds: These scaffolds are fairly versatile but require more time to erect and dismantle compared to the welded frame type of scaffold. They are suited for access scaffolding and slab staging of industrial structures. All-purpose units consist of two vertical and one horizontal unit which are interconnected by ordinary 40 mm. NB M.S. tubes called ledgers.

5. CUPLOK systems - This is among the most versatile modular scaffolding arrangements in the world. Its unique node point connection makes it a fast assembly scaffolding. The absence of loose parts and a unique cup action allows four horizontal units to be fixed or released in a single operation by means of only a hammer. Careful selection of raw materials for various components such as higher grade YST-240 tube, malleable cast iron top cups, deep drawn steel of bottom cups and drop-forged ledger blades makes it a sturdy and yet light scaffolding system. It is ideally suited for all access scaffolds and slab staging for any type of construction. The prime feature of CUPLOK is that since its vertical member has cup joints at every 500 mm. One has to just change the location of the horizontal units (thereby reducing or increasing l/r ratio) for different loading conditions without changing the size or thickness of the vertical tubes. Modular scaffolding systems have been effectively used for boiler maintenance, chimneystacks, access, flyovers, silos as well as offshore structures/ship building and repairs. These systems prove economical as they cut down erection time significantly.

6. Slab shuttering & support systems - From the days of timber shuttering & wooden props, slabs shuttering and centering have come a long way. The various slab shuttering systems are:

a) Conventional span-prop arrangements: Adjustability of the components makes the system versatile for normal slab shuttering.

b) Shuttering for heavier slab/deck slab - Specially designed shutters are made for jobs such as slab of industrial building, flyovers, bridges, etc.

c). Metriform unit – Decking arrangements: These consist of modular Metriform beams and panels while supporting the slab on drop-heads fitted over steel props or scaffolds. Slab shuttering can be removed in three days instead of the regular seven days thereby considerably increasing the rotation of shuttering materials. It is thus ideal for today's time-bound projects.

d) Shuttering for waffles troughs - Made out of moulded plastic materials to give architectural finish.

e) Flying form - This includes the crane-handled formwork of a complete floor slab of a building for speedy completion. All the slabs of the building should be identical in this case.

f) Support staging - Slab/beam staging is normally effected through adjustable steel props or any type of system scaffold depending on the height and load of the structure to be taken on support staging.

7. Wall / column shuttering - The construction of RCC walls/columns requires sturdy shuttering to take care of concrete pour pressures. The systems generally available are:

a) Conventional channel/heavy duty soldier - This consists of steel panels connected side by side with soldiers. Heavy duty soldiers are used for one-sided shuttering such as for RCC piers, retaining walls, etc. these are ideal for lift walls, shear walls, RCC piers, columns etc.

b) Heavy duty/ strong back arrangement - This is meant for a pour height of up to 5 m. using J-4 or Slimlite back-up soldiers. Shuttering can be of steel/ply with soldiers provided as back-ups, behind the shutters. It is ideal for fast concreting, with the help of pumps and can be crane-handled.

8. Special shuttering - Construction of special structures also requires suitable formwork. Some of the applications are:

a) Slip form of chimneys/silos: Hydraulically lifted complete shuttering by means of heavy duty jacks enables concreting of a tall chimney in hardly any time as more often the slipping (or concreting) is continuous once it starts.

b) Dam shuttering: Special heavy duty hinged soldiers along with heavy shutters are used to match the profile of a dam.

c) Canal lining: Mobile shutters are specially designed to move along the canal, for the concrete lining.

d) Bridge shuttering: Shutters for girders are specially designed to take care of concreting loads.

9. Conclusion - It is obvious that modern shuttering and scaffolding systems, which are continuously evolving, are among the most important aspects of construction and maintenance. Unfortunately, so far neither the industry nor the engineering institutions have really gone into the relevance and details of this equipment are which should be utilized for effecting proper and economical designs for particular applications. With the advent of professional scaffolding organisations and realisation of the need on the part of the industry for safer, faster and economical construction, one hopes for the development of this long-neglected but important area in the near future is going to be a reality.

Annexure 4.A.-6

CONCRETE CHEMICALS

General - The use of admixtures in concrete, of late, has assumed greater importance in the field of concrete technology, There are quite a few new materials in the market. They are used in cement as an additive, in mortar and concrete as admixtures. Such additives and admixtures are sometimes collectively called construction chemicals. About ten years ago although such materials were in use in other countries, they were not freely available in our country. Sometimes, they were imported at great cost for specific use but such admixtures were not widely used. Therefore not only the state and central government department specifications, but also engineering practices by private bodies did not give much importance to the use of these construction chemicals. On the other hand, in other advanced or advancing countries, concrete is very rarely made without the use of one or other admixtures.

For the last nearly ten years, a number of international firms, manufacturing construction chemicals, have transferred their technologies to India. In collaboration with companies like MC-Bauchemie of West Germany, Fosroc Chemicals of U.K., Sika Qualcrete of Switzerland, and Feb. Ltd. of U.K., this list is illustrative but not exhaustive, Indian companies have started manufacturing a wide range of construction chemicals. In addition to the above, there are number of Indian companies manufacturing a wide range of admixtures and construction chemicals. All the same these companies have made valuable contribution to Indian construction industries.

In the past, admixtures have been used very rarely with the exception in the fifties of Surkhi as pozzolanic admixture and air entraining agents as workability agents in multipurpose dams. In cold weather regions, calcium chloride was also used as an accelerating admixture. In addition a number of integral waterproofing compounds were in the market. Either due to lack of knowledge or due to non-availability of other appropriate and efficient materials, cement has been used as an all-purpose,

ubiquitous material. When better workability is required we have used more cement and more water. For grouting of dams was used cement. For cladding of walls with tiles, stones, marble or granite, was used cement. In short, in the field of construction, cement was used for all purposes.

While cement is a good bonding material, it has many disadvantages. Long term drying shrinkage is one of the worst facets of cement. The excessive heat of hydration of rich concrete, the dissolution of $\text{Ca}(\text{OH})_2$, susceptibility of concrete to sulphate attack and carbonation are some of the other disadvantages that make concrete an inefficient material. It was once thought that concrete structure could not be repaired as the bond between old concrete and new concrete could not be obtained satisfactorily. It was also thought that concrete structures once made did not require repair and maintenance, Some of these perceived disadvantages and misconceptions no longer hold good. We know now that modern construction chemicals available today all over the world and in India have helped to enhance the versatility of concrete as an efficient construction material in a wide variety of situations in the field of construction engineering.

Modern concrete admixtures and construction chemicals that are manufactured in India in collaboration with some of the international companies named earlier are dealt with. These companies have been working in a number of countries in different climatic conditions for more than two to three decades. For general information, the extended topic, construction chemicals, has also been included in this section since these construction chemicals are in a way associated in improving the performance of concrete. It is hoped that will be of immense practical use to all concerned with concrete technology as applied to construction engineering, since it attempts to lay out the state of the art as far as concrete admixtures are concerned.

The following materials will be discussed in this section:

- (a) Plasticizers and Super Plasticizers
- (b) Retarding Plasticizers and Retarders
- (c) Accelerating Plasticizers and Accelerators
- (d) Air entraining Agents
- (e) Water Proofing Materials
- (f) Polymer bonding agents
- (g) Floor Hardeners and Dust Proofers
- (h) Concrete Curing Compounds
- (i) Polymer Mortar for Repair and Maintenance
- (j) Adhesives for Tiles, Marble and Granite
- (k) Mould Releasing Agents
- (l) Grouting Agents
- (m) Joint Sealant
- (n) Decorative cum Protective Paints
- (o) Concrete Repair System
- (p) Installation Aids
- (a) Plasticizers and super-plasticizers

Plasticizers - Right workability is the essence of good concrete. Concrete in different situations requires different degree of workability. A high degree of workability is required in situations like deep beams, thin walls of water retaining structures with high percentage of steel reinforcement, column and beam junctions, Tremie concreting, pumping of concrete, hot weather concreting, for concrete to be conveyed for considerable distance and in ready mixed concrete industries. The conventional methods followed for obtaining high workability is by improving the gradation, or by the use of relatively higher percentage of fine aggregate or by increasing the cement content. There are difficulties and limitations to obtain high workability in the field for a given set of conditions. The easy method generally followed at the site in most of the conditions is to use extra water unmindful of the harm it does to the strength and durability of concrete. It has been stressed time and again to the harmful effect of using extra water than necessary. It is an abuse, a criminal act, and un-engineering to use too much water than necessary in concrete. At the same-time, one must admit that getting required workability for the job in hand with set conditions and available materials is essential and often difficult. Therefore, engineers at the site are generally placed in conflicting situations. Often, he follows the easiest path and that is adding extra water to fluidize the mix. This addition of extra water to satisfy the need for workable concrete is amounting to sowing the seed of cancer in concrete.

Today plasticizers and super plasticizers help an engineer placed in intriguing situations. These plasticizers can help the difficult conditions for obtaining higher workability without using excess of water. One must remember that addition of excess water will only improve the fluidity or the consistency but not the workability of concrete. The excess water will not improve the inherent good qualities such as homogeneity and cohesiveness of the mix, which reduces the tendency for segregation and bleeding. Whereas the plasticized concrete will improve the desirable qualities demanded of plastic concrete. The practice all over the world now is to use plasticizer or super plasticizer for almost all the reinforced concrete and even for mass concrete to reduce the water requirement for making concrete of higher workability or flowing concrete. The use of super plasticizer has become almost a universal practice to reduce water/cement ratio for the given workability, which naturally increases the strength. Moreover, the reduction in water/cement ratio improves the durability of concrete. Sometimes the use of super-plasticizers is employed to reduce the cement content and heat of hydration in mass concrete.

The organic substances or combinations of organic and inorganic substances, which allow a reduction in water content for the given workability, or give a higher workability at the same water content, are classified as plasticizing admixtures. The advantages are considerable in both cases: in the former, concretes are stronger, and in the latter they are more workable.

A good plasticizer fluidizes the mortar or concrete in a different manner than that of the air-entraining agents. Some of the plasticizers, while improving the workability, entrains air also. As the entrainment of air reduces the mechanical strength, a good plasticizer is one, which does not cause air-entrainment in concrete by more than 1 or 2%.

Super-plasticizers

Super-plasticizers constitute a relatively new category and improved version of plasticizers for concrete, the use of which was developed particularly in Japan and Germany from the sixties.

Super-plasticizers can produce:

- (i) At the same w/c ratio, much more workable concrete than the plain ones.
- (ii) At the same workability, a considerable decrease in the w/c ratio, and therefore concrete having higher strength.

In case of (i) above, it is possible to obtain the so called "flowing concrete" or "self-leveling concrete" which is pumpable or needs very little compacting efforts for compaction. In the fluidized concretes, the phenomenon of aggregate segregation or water separation are practically absent, and anyhow much reduced than in the case of normal plasticizers.

Super-plasticizers are generally grouped in the following categories:

1. Sulphonated melamine - formaldehyde condensates (MSF).
2. Naphthalene Sulphonate - formaldehyde condensates (NSF).
3. Modified Lignosulphonates (LS).
4. Other types.

Each category includes products differing from one another because either the base component can have different molecular weights or may have undergone some chemical changes or other chemical substances can be present. As a consequence, each commercial product will have different action on cements. Whilst the dosage of conventional plasticizers do not exceed 0.25% by weight of cement in case of lignosulphonates, or 0.1% in case of carboxylic acids, the products of groups (1) or (2) are used in considerably high dosages (0.5% to 3.00%), since they do not entrain air. Group (3) includes admixtures which have an effective fluidizing action, but at the relatively high dosages, they can produce undesirable effects, such as accelerations or delays in setting times. Moreover, they increase the air-entrainment in concrete.

Plasticizers and super plasticizers are water based. The solid contents can vary to any extent in the product manufactured by different companies. Cost should be based on efficiency and solid content, but not on volume or weight basis. The composition of different samples can be qualitatively compared by "Infrared spectrometry".

Effects of super-plasticizers on fresh concrete

It is to be noted that dramatic change in workability is not achieved when super-plasticizers are added to very stiff, zero slump concrete. A mix with an initial slump of about 2 to 3 cm can only be fluidized with plasticizers or super-plasticizers. An improvement in slump value can be obtained to the extent of about 25 cm depending upon the initial slump and dosage. It has been seen that slump increases with increase in dosage. But there is no improvement in slump beyond certain limit of dosage. As a matter of fact the overdose may harm the concrete. A typical curve is shown in Figure 1

Fig 1 Effects of additions of super plasticizers on the workability of a concrete. Cement content 300 kg/m³, w/c ratio = 0.6

The type of cement affects the plasticizer's influence in fluidizing the concrete. The compatibility of particular super-plasticizer with that of cement to be used must be taken into account. This can be done by simple field trial.

A negative property of super-plasticizers is the workability loss with time (slump loss). Figure 2 shows the typical slump loss with time.

Fig 2 Slump loss with time

Different methods are proposed to reduce the slump loss with time, such as, for example, adding super-plasticizer to concrete immediately before its placing or delayed addition, or at small successive doses or over by over dosing it.

The delayed addition of super-plasticizer reduces the loss of slump. Figure 3 shows the effect of delay on slump loss. It is suggested that concrete be first mixed with most of the water and the super-plasticizer is then added with the remaining water.

Effect of the delayed addition of sulphonated melamine formaldehyde condensate on slump loss

The effect of repeated dosages of super-plasticizers to reduce the loss is shown in Figure 4.

One of the practical methods for reducing the slump loss is to formulate super-plasticizers, incorporating retarding admixtures. By this way, slump can be maintained for about 3 hrs.

Effect of super-plasticizers on hardened concrete - It is a shared opinion that, by working at constant w/c ratio, the strength of concrete is normally improved by the use of super-plasticizers on account of better compact ability of concrete. Over dose of super-plasticizers bring about a small reduction of strength. If super-plasticizers are used to reduce the w/c ratio, by keeping the slump equal to that of reference concrete, much higher strengths are generally obtained. This effect is found also on mortars. Within certain limits, the effect is proportional to the amount of super-plasticizers added but beyond certain dosages, strength tends to decrease. It is therefore important to avoid excessive dosages. As regards the long-term strength of concrete containing super-plasticizers, there are no exhaustive case studies. However, unsatisfactory results have not been reported.

Effect of repeated dosages of sulphonated Naphthalene formaldehyde condensates on slump

At the same w/c ratio, sulphonated melamine formaldehyde condensate (MSF) and naphthalene sulphonated formaldehyde condensate (NSF) do not considerably modify drying/shrinkage of concrete. At the same consistency, they sometimes reduce drying/shrinkage appreciably.

The total creep is higher when concrete contains Naphthalene Sulphonate at high w/c ratio (0.64). On the contrary, when the w/c ratio is low, the difference in creep between samples with or without super-plasticizers is insignificant.

Impermeability plays a primary role on the durability of concrete and since this depends on w/c ratio, super-plasticizers should exert a favorable effect. Super-plasticizers, owing to the reduction in w/c ratio, reduce the penetration of chlorides and sulphates into the concrete and therefore improve their resistance to the de-icing effect of salt or sea water. For the same reason, the resistance to the sulphate attack is also improved.

Mechanism of action of super-plasticizer

Interpreting the mechanism of the action of plasticizers and super-plasticizers is rather complex owing to the variety of compounds forming the family of these admixtures and to the composite nature of

cement and concrete. However, the following can be forwarded to explain the mechanism by which these admixtures bring about in improving the plasticity of the concrete.

The fluidizing effect is, at least partly, the consequence of retarding phenomena caused by the plasticizers and super-plasticizers on the cement hydration. Infact, the mixing water reacts more slowly with the cement and therefore it remains available for longer time to fluidize the mix.

The dispersing action of plasticizers is attributed to the adsorption of plasticizer molecules on the cement grains as well as to the resulting changes in the surface charge and zeta potential of the solid particles. The charges of the same sign cause repulsive forces, which results in the solid dispersion and therefore increase the mix plasticity.

From what has been said above, it can be seen that use of plasticizers and super-plasticizers can make significant contribution for improving the strength and durability of cement concrete. The innovation and use of these materials started during 1970 and has become one of the milestones in the short history of cement concrete. It is a boon in the hands of concrete technologists and construction engineers.

Table gives the list of a few commercial names of plasticizers and super-plasticizers available in India.

(b) Retarding plasticizers and retarders - it is usual to incorporate the retarding admixtures as an integral part of super-plasticizers. Therefore, retarding plasticizers are available in the market today. They are suitable for achieving long retardation for avoiding the construction joints. The retarding plasticizers are frequently used to reduce the loss of slump, in hot weather concreting or for conveying concrete over long distances.

Retarding plasticizers. Retarding Plasticizers are sometimes required for slip form method of construction. Since retarding super-plasticizer retard the setting action of cement particles over considerable time, they regulate the evolution of heat of hydration in mass concrete. Sometimes they are of special requirements for roughening the surface of concrete roads and pavements. In ready mixed concrete industries, the retarding super-plasticizers often become essential requirement.

Retarders. . Sometimes it will be advantageous to mix high performance set retarding admixtures separately into the concrete. These set retarding agents can be admixed separately along with normal plasticizers or super-plasticizers.. The dose of retarders independently depends on the situation.

(c) Accelerating and accelerators - Certain ingredients are added to accelerate the strength development of concrete to super-plasticizers to offer high early, strength to the concrete. Such accelerating super-plasticizers, when added to concrete result in faster development of strength. This enables early stripping of moulds ensuring speedy construction as well as overall economy on account of lesser formwork requirements. Accelerating plasticizers can be used in prestressed concrete works as well as in precast industry for manufacturing building elements, poles, pipes, piles, concrete sleepers etc. Accelerating plasticizers can give strength of about 1.6 times that of reference concrete in one day.

Accelerators - The use of calcium chloride as an accelerating material has been widely produced. However, some recent studies have indicated that calcium chloride is not the right material for acceleration of strength and the addition of chloride in any form should be avoided from the durability

consideration, particularly for reinforced and prestressed concrete. As such it is particularly emphasized that all modern admixtures should be free from chlorides.

Even the BIS specifications for ordinary and high strength cement, is reconsidering the reduction of permissible chloride content in the cement, from what is permitted in the current code of practice.

The modern accelerating admixtures are completely chloride free. Some of the accelerators produced these days are so powerful that it is possible to make the cement set into stone-hard condition in a matter of 10 minutes or less. With the availability of such powerful accelerators the under water concreting has become comparatively easy. Similarly the repair work that could be carried out to the waterfront structures in the region of tidal variations has become easy. The use of such powerful accelerators has facilitated the basement waterproofing operations. In the field of prefabrication also it has become an invaluable material. As these materials could be used even up to -10 degree Celsius, they find an unquestionable use in cold weather concreting.

(e) Waterproofing materials - In spite of many fold advancement made in Concrete Technology and the ability to produce high quality concrete, it has not been possible to really make waterproof structures. The problem of water proofing of roofs, walls, bathrooms, toilets, kitchens, basements, swimming pools, and water tanks etc. have not been much reduced. There are number of materials and methods available in the country for waterproofing purposes. But most of them fail due to one or the other reasons. Waterproofing has remained a complex problem. A successful waterproofing not only depends upon the quality and durability of material but also the workmanship, environment and type of structures. Leaving all other aspects, the material part is only discussed below.

It should be remembered that the use of plasticizers, super-plasticizers, air-entraining agents, pozzolanic materials and other workability, agents, help in reducing the permeability of concrete by reducing the requirement of mixing water and hence they can also be regarded as waterproof material. In addition, there are other materials and chemicals available for water proofing concrete structures.

These materials can be grouped as follows:

- (i) Integral waterproofing compounds
- (ii) Waterproofing liquid membrane
- (iii) Waterproof slurry coatings
- (iv). Water repellent materials
- (v) Injection grout for cracks
- (vi). Waterproof tile adhesive and
- (vii) Sealing materials for rising dampness

(i) Integral Waterproofing Compounds - The performance of integral waterproofing compounds is covered in IS 2645. They have limited utility in making the concrete waterproof. They are not of much help for the possible cracks on account of drying shrinkage and cracks on account of thermal variations. They are of some help in a situation where concrete is continuously in wet or damp conditions.

(ii) Waterproofing liquid membrane - For roof waterproofing, a membrane forming material is an ideal material. The membrane should be tough, wear resistant, solar reflective, elastic, elastomeric and

durable. They are to be applied on roof strictly as per manufacturers' instructions with special care to surface preparation. Attempts are being made to formulate polyurethane and polymerized bitumen as membrane forming waterproof materials for roof.

(iii) Waterproof slurry coatings - Waterproofing of concrete, brick masonry and cement bound surfaces can be obtained by a specially made slurry coatings. Slurry consists of specially processed hydraulically setting powder component and a liquid polymer component. These two materials when mixed in a specified manner form brushable slurry. Two coats of this slurry when applied on roof surface or on any other vertical surface in a basement, water tank or sunken portion of bathroom etc. forms a long lasting waterproofing coat. This coating requires curing for a week or so. The coating so formed is elastic and abrasion resistant to some extent. To make it long lasting mortar screeding or tiles may protect the coatings.

A modified version of the above has been made to give a better waterproofing and abrasion resistance to the treatment. This will make the coating tough, more elastic and waterproofing. This modified version of waterproofing system is especially applicable to terrace gardens, parking places, basements, swimming pools, sanitary areas etc. This coating also gives protection to chlorides, sulphates and carbonation attack on bridges and to underground structures.

(iv). Water repellent material - Sometimes shrinkage or thermal cracks appear on mortar joints of masonry walls or on plastered surfaces. A spray of transparent water repellent, silicone based material can make it effective for duration of two to three years.

(v) Injection grouting for cracks - Injection grouting is one of the powerful methods commonly adopted for stopping leakages in dams, basements, swimming pools construction joints and even in the leaking roofs. A few years back cement was used for grouting purposes. Cement is not an ideal material for grouting, as it shrinks while setting and hardening. Non- shrink or expansive cementing material is the appropriate material. We have quite a few materials available in the market for filling up cracks and crevices in concrete structures to make them waterproof or for repair and rehabilitation of structures. The grouts are produced with selected water repellent, silicifying chemical compounds and inert fillers to achieve varied characteristics like water impermeability, non-shrinkage, free flowability etc. They are suitable for gravity grouting as well as pressure grouting. Grouting of concrete structure is one of the powerful methods for strengthening and waterproofing of unhealthy structures.

(vi). Waterproof tile adhesive - Wet areas in buildings such as lavatory, bathroom and kitchen are the vulnerable places for leakage. Normally glazed tiles are used as one of the methods of waterproofing wet areas. Generally neat cement paste is used for fixing glazed tiles. The present practice often gives unsatisfactory results on account of poor joint filling by cement paste. The paste applied to the back of the tiles does not flow towards the edges of the tiles and as such joints remain unfilled. The white cement applied later for filling joints also becomes ineffective. It is a common sight that paints and plasters peel off behind such wet areas due to lack of waterproofing.

There are adhesives for fixing glazed tiles, ceramic tiles or marble in wet areas in buildings. They are first screeded directly on to the wall 2 to 3 mm thick and then glazed tiles or other tiles are pasted onto this screed. As this screed is a powerful adhesive as well as an effective waterproofing material, it provides a waterproofing coat to the wall. Adoption of such polymer based hydraulically setting ready

to use waterproof tile adhesive in the wet areas will go a long way to make wet areas of buildings waterproof.

(vii) Sealing materials for rising dampness - Often old buildings are not provided with damp-proof course. The water from the ground rises by capillary action. This rising water brings with it the dissolved salts and chemicals, which result in peeling of plaster affecting the durability of structure, and also make buildings un-hygienic. Attempts were made to cut the wall in stages and introduce new DPC, but this method has not only been cumbersome but also ineffective. Now materials that can be injected into the wall at appropriate levels to seal the capillaries and thereby to stop the upward movement of water are available. The Table 2 gives the brand name of some of the water proofing materials manufactured by different companies for different purposes.

(f) Polymer bonding agents - It is a well-known fact that there will not be perfect bond between old concrete and new concrete. Quite often new concrete or mortar is required to be laid on old concrete surface. For example, for providing an overlay on an existing pavement, in providing a screed over roof for water proofing or repair work etc. The bonding characteristics can be greatly improved by providing a bond coat between old and new concrete surface or mixing the bonding agent with the new concrete or mortar. The use of bonding agent distinctly improves the adhesion of new concrete or mortar to old surface. The mixing of bonding agents with concrete or mortar improves the workability also at lower water cement ratio and thereby reduces the shrinkage characteristic. It also helps in water retention in concrete to reduce the risk of early drying. It further improves the water proofing quality of the treated surface

(g) Floor hardeners and dust proofers - Floor is one of the parts of any building, particularly the industrial building, continuously subjected to wear and tear. The factory floor, on account of movement of materials, iron tyred trollies, vibrations caused by running machines is likely to suffer damages. Wear resistant and chemical resistant floor must be provided in the beginning itself. Replacing and repairing of old floor will interfere with the productivity and prove to be costly.

In the past, materials such as ironite, Hardonate, Metarock and other liquid floor hardeners were used to give better performance. But performances of these materials were not found to be satisfactory. Now we have modern floor toppings materials composed of carborundum or emery powders, systematically graded, mixed with processed and modified cement. This mixture when sprinkled over wet concrete floor of sufficient strength and depth is found to give an effective wear resistant, dust free, non-slip floor. The quantity to be sprinkled is depending upon the degree of wear resistance required.

One difficulty is experienced in the application of wear resistant hard top materials on the wet base concrete. If the sprinkling of this material is done when the base concrete is too wet, the finishing operation will make these hard-wearing topping material sink, thus making the process ineffective. On the other hand if the sprinkling is delayed, the base concrete will have been set and hardened to such an extent that the hardtop material will not become integral part of the floor. The hard topping material should be sprinkled at the appropriate time for optimum result.

Recently vacuum de-watering method is frequently adopted for casting factory floor, road, air field pavements and concrete hard standing. In India TREMIX SYSTEM or JAMSHEDJI VACUUM de-

watering system is popular. Employment of vacuum de-watering of concrete for factory floor by itself will give improved performance to factory floor. In addition, vacuum de-watering offers an ideal condition for wide casting the floor topping on the top of the concrete floor slab. The hard wearing, sized and graded aggregate forms the top surface of concrete floor to offer tremendous abrasion resistance.

There are also certain materials which when applied on the concrete floor, convert the lime rich cement compounds into silicified products which gives extreme chemical and mechanical resistance and also dust-proofing qualities.

(h) Concrete curing compounds - On account of the requirement of large quantity of water for curing, especially for vertical surfaces, sloping surfaces such as canal lining, water curing becomes costly and often inefficient. Continuous uninterrupted curing of concrete does not really take place at the site.

(i) Polymer mortar for repair and maintenance - Sometime concrete surfaces require repair. The edge of concrete columns may get chipped off; or ceiling of concrete roof may get peeled off, or a concrete floor may get pitted in course of time. Hydraulic structures often require repairing. Prefabricated members such as pipes, poles, posts and roofing elements often gets chipped off while stripping from form work, handling and transportation, in the past cement mortar is used for any kind of repair and as an universal repair material. Cement mortar is not the right kind of material for repair. Now there are many kind of repair materials, mostly polymer modified, are available for effective repair. They adhere very firmly to the old concrete surface on account of greatly improved bond characteristics. These materials are often stronger than the parent materials.

(f) Adhesives for glazed tiles, marble and granite - The normal practice followed for fixing glazed tiles in bathroom, lavatory, kitchen, and other places is the use of stiff neat cement paste. The existing practice, though somewhat satisfactory in the indoor conditions from the point of fixity, such practice is 'unsatisfactory' when used in outdoor conditions and also from the point of view of waterproofing quality. The cement paste applied at the back of tiles does not often flow towards the edges of the tiles and as such water enters at the edges, particularly when white cement applied to the joints become ineffective. In large number of cases it is seen that paintings and plaster gets affected behind these glazed tiles supposedly applied to prevent moisture movement from wet areas.

Cement paste is not the right material for fixing the glazed tiles. There are polymers based, hydraulically setting, ready to use waterproof tile adhesive available in the market. They offer many advantages over the conventional method of tile fixing such as higher bond and adhesion strengths, faster work, and good waterproofing quality to the wall. They are suitable for exterior and overhead surfaces. No curing of tile surface becomes necessary. If the wall and plastered surface is done to good plumb, a screeding of only 1-2 mm thickness of this modern material will be sufficient to fix the tiles in which case, the adoption of this material will also become economical. The modern tile adhesive material will offer special advantages for fixing glazed tiles in swimming pools both on floor and at sides. It provides one more barrier for the purpose of waterproofing.

Many a time, the glazed tiles fixed on the kitchen platform or bathroom floor gets dirty or damaged. It requires to be replaced. Normal practice is to remove it by chipping the old tile, screed cement paste or mortar and then lay the new tiles. With modern tile adhesive, it is not necessary to remove the old

tile. Tile adhesive can be screeded on the existing tile and new tiles are laid over the old tiles. The bonding quality is such that good adherence takes place tile over tile. This saves considerable cost and time and the operation becomes simple.

Marble and granite are increasingly used for cladding wall surfaces both internally and externally. Marble and granite have become the most common treatment for external treatment of prestigious buildings. They are used in the form of tiles or large panels. In the past for fixing thin marble and granite tiles cement paste was used and for fixing large slabs and panels, epoxy and dowel pins were used. Now there are specially made ready to use high strength polymer bonding materials available, which can be used with confidence, both for internal and external use. Requirement of dowels is eliminated in most of the cases except for cladding of large panels at very high level for extra safety. Marble and granite can even be fixed on boards or inclined surfaces or even underside of beams and ceilings by the use of new powerful adhesive.

(k) Mould releasing agents - Wooden planks, ordinary plywood, shuttering plywood, steel plates etc is used as shuttering materials. Concrete when set and harden adhere to the surface of the formwork and make it difficult to demould. This affects the life and quality of shuttering materials. At times when extra force is used to demould from the formwork, concrete gets damaged. Sometime mould surface could be cement plastered surface, in which case the de-moulding or stripping of concrete member becomes all the more difficult. In the past to reduce the bond between form work and concrete, some kind of materials such as burnt engine oil, crude oil, cow dung wash, polyethylene sheet etc. were used. All the above are used on account of non-availability specially made suitable and effective mould releasing materials. Now we have specially formulated mould-releasing agents, separately for absorptive surfaces like timber and plywood and for non-absorbent surface like steel sheet is available.

(l) Grouting agents - Grouting aspects have been discussed earlier while dealing with waterproofing of basement slab and other concrete structure showing excess of permeability. Apart from the above, grouting has become one of important in civil engineering construction. Grouting below base plate or machine foundations, grouting of foundation bolt holes in industrial structures, grouting of prestressed concrete duct, grouting in anchoring and rock bolting systems, grouting of curtain walls, grouting of fissured rocks below dam foundation, grouting the body of the newly constructed dam itself, grouting of deteriorated concrete or fire affected structures to strengthen and rehabilitate, grouting of oil wells are some of the few situations where grouting is resorted to.

The grout material should have high early strength and ultimate strength, free flowing at low water content, should develop good bond with set concrete, essentially it should be non-shrink in nature.

The grouting materials can be broadly classified into two categories. One is free flow grout for use in machine foundations, foundation bolts and fixing crane rails etc. The second category of grout is meant for injection grouting to fill up the small cracks, which will be normally done under pressure.

(m) Joint sealant - Joints in buildings, bridges, roads and airfield pavements are inescapable. They may be expansion joints, construction joints or dummy joints. Such joints must be effectively sealed to facilitate movement of structure, to provide waterproofing quality or to improve the riding qualities. While providing large openings and windows in buildings there exists gap between wall and window

frames, through which water flows inside. Such gaps in the windows should also be effectively sealed. The gaps resulting in installation of sanitary appliances are required to be sealed. There were no effective materials in Indian market hitherto.

(n) Decorative and protective paints - It was a popular belief that concrete structures do not require protection except when used as a pile in corrosive or sulphate infested environment or when concrete piles are subjected to abrasion and mechanical wear and tear. Lately it was found that concrete structures built in, and around coastal region, in and around fertilizers and chemical factories, cooling towers and chimneys need definite protection against disruptive action of aggressive environmental agencies. Sometimes it is also necessary that concrete structures such as flyovers and bridges should be made to look decorative and beautiful.

Many beautiful structures built near seashore get affected within a matter of few years. The delicate sections of sun breakers, louvers, facia, facades, sun shades and chajjas crack and spall off within a matter of ten years particularly when the cover provided to these thin members becomes inadequate. Hand mills of bridges become most vulnerable. Even bridge girders get affected and show premature distress. Carbonation is supposed to be one of the main reasons for initial straining and eventual cracking of the concrete members. The above degradation can be retarded by giving protective coatings particularly to the delicate concrete members.

Of late it has been realized that life of concrete structures in general and their elements in particular can be greatly enhanced if they are painted with crack bridging protective coatings. Such protective coatings are intentionally made decorative. They cover up staining, craziness and cracks in plaster and further provide resistance to carbonation and moisture penetration, while making the concrete structures decorative.

(o) Concrete repair system - It was once thought that concrete structures are durable and last almost forever. But now it is realized that concrete is not as durable as it was thought to be. It was also the earlier belief that concrete needs no protection. It is discussed above that concrete needs to be maintained and protected. Another wrong notion that prevailed was that concrete couldn't be repaired. Now there are materials and methods for effective repair of damaged concrete structures, which is discussed below.

Concrete is constantly under attack of environmental pollution, moisture ingress, penetration of chlorides and sulphates and other deleterious chemicals. The durability of concrete is then affected. Of all forces of degradation, carbonation is believed to be one of the potent causes of deterioration of concrete.

Carbonation is the process where-in atmospheric carbon dioxide reacts with concrete's alkaline calcium hydroxide in the presence of moisture, or humidity, to convert it into calcium carbonate; the pH value of pore water of fresh concrete is from 12.5 to 13.5. On this strong alkaline environment the embedded steel reinforcement does not corrode. The carbonation process lowers the pH value of pore water to below 9 and disturbs the passivating protection to the reinforcement. The reinforcement then begins to rust. The volume of rust is about 2.5 times the volume of parent metal replaced. This extra volume of rust causes stress that pushes the protective cover resulting in cracks and spoiling.

This process progressively increases with time, till such time the reinforcement is fully exposed. This kind of carbonation of concrete and subsequent progressive deterioration and failure is aptly described as concrete cancer.

The depth of carbonation depends upon the strength level of concrete, permeability of concrete, duration and whether the concrete, is protected or not.

Figure 5 shows the depth of carbonation for protected and unprotected concrete.

The Figure 6 shows the depth of carbonation with respect to strength (grade) of concrete.

In the past, there was no effective method of repairing cracked, spalled and deteriorated concrete. They were left as such for eventual failure. In the recent past, guniting was practiced for repair of concrete. Guniting has not proved to be an effective method of repair. But now very effective concrete cancer and increase the longevity of the structure. The repair materials used are stronger than the parent material. The efficient bond coat, effective carbonation resistant fine mortar, corrosion inhibiting primer, protective-coating makes the system very effective. Where reinforcement is corroded more than 50%, extra bars may be provided before repair mortar is applied. The whole repair process becomes a bit closely but often repair is inevitable and the higher cost does not matter much.

Fig 5 Depth of carbonation for protected and unprotected concrete

Fig 6 Depth of carbonation with respect to strength (grade) of concrete

(p) Installation aids – Many a time we leave holes or make holes in walls, staircases, gate pillars, etc. for fixing wash basin, lamp shades, hand rails or gates etc. Invariably, the holes made or kept, are larger than required. The extra space is required to be plugged subsequently. Material used in the past is cement mortar. Cement mortar takes a long time to set and harden, remain vulnerable for damage and it also shrinks. We have now specially manufactured materials, which will harden to take load in a matter of 10 – 15 minutes and work as an ideal material from all points of view for the purpose of fixing such installations. They can also be used for fitting of antennae, fixing of pipes and sanitary appliances etc

Water tanks, deep pump houses, basements, pipes carrying water or seepage, sometimes develop cracks and leaks. Such leakage's can be plugged by using a special ready to use mortar for quick and reliable sealing and plugging of any kind of leaks. This stiff mortar is kept pressed against the crack for 5 to 7 minutes. Sometimes depending upon the shape of the crack etc., the first attempt may not bring 100% result. Probably a second attempt or third attempt may be required. Figure 9 illustrates the use. It is also used in the grouting operation for fixing the nozzle and also for stopping the grout escaping from elsewhere.

CONCRETE WORK --- LIST OF BUREAU OF INDIAN STANDARDS

Sl No	IS No.	Subject
1	306-1983	Tin bronze ingots and castings (3rd revision) Reaffirmed 1993.
2	383-1970	Coarse and fine aggregate from Natural source for concrete (2nd revision) Reaffirmed 1990.
3	456-2000	Code of practice for plain and reinforced concrete (3rd revision) (Amendments

		2) Reaffirmed 1991.
4	516-1959	Method of sampling and analysis of concrete. Reaffirmed 1991.
6	1200 (Part II) 1974	Method of measurement of building and civil engineering work Part 2 (concrete works). (3rd revision) (Amendments 2) Reaffirmed 1991.
7	1322-1993	Bitumen felt for water proofing and damp proofing (4th revision) (previously 13220-1982)
8	1791-1985	Batch type concrete mixers. (2nd revision) Reaffirmed 1990.
9	2386-1963	Method of test for aggregate for concrete work. a) Part 1 particle size and shape (Amendments 2) Reaffirmed 1990
		b) Part 2 Estimation of deleterious materials and organic impurities (Amendments 1) Reaffirmed 1990.
		c) Part 3 Specific gravity, density, voids, absorption and bulking – Reaffirmed 1990.I
		d) Part 4 Mechanical properties (Amendments 3) Reaffirmed 1990.
10	2505-1980	General requirements for concrete vibrators immersion type. Reaffirmed 1993.
11	2505-1985	General requirements for screed board concrete vibrators. (1st revision) Reaffirmed 1990.
12	2645-1975	Integral cement water proofing components (1st revision) (Amendments 1) Reaffirmed 1992.
13	2686-1977	Cinder as fine aggregate for use in lime concrete (1st revision) (Amendments 1) Reaffirmed 1992.
14	3068-1986	Broken butnt (clay) coarse aggregate for use in lime concrete. (2nd revision) Reaffirmed 1991.
15	3812-1981	Flyash for use as pozzolana and admixtures (1st revision) Reaffirmed 1992.
16	4643-1984	Section wrenches for fire bridge use (1st revision) Reaffirmed 1992.
17	4656-1968	Form vibrators for concrete. Reaffirmed 1991.
18	7861 (Part 1) 1981	Code of practice for extreme weather concreting (Part 1) recommended practice for hot weather concreting (Amendments 1) Reaffirmed 1990.
19	7861 (Part 2) 1975	Code of practice for cold weather concreting (Part 2) Recommended practice for cold weather concreting (Amendments 1) Reaffirmed 1992.
20	9103-1979	Admixture for concrete Reaffirmed 1990.

3. SPECIFICATIONS FOR STEEL FOR CONCRETE REINFORCEMENT .

0.1. Deformed bars for concrete reinforcement are being produced in the country for many years, the main processes being hot rolling or hot rolling followed by cold twisting. In the past decade there has been an increasing demand for higher strength deformed bars (415 N/m², Min, yield strength/0.2 percent proof stress being the most common). This high yield strength was being first achieved by

raising carbon and manganese and to a great extent by cold twisting.

0.2. Micro-alloying with Nb, V, Ti and B, in combination. Individually, and thermo-mechanical treatment process are worth mentioning in tills field. With these two processes higher strength values could be achieved at low carbon levels even in large diameter bars.

1. Scope

1.1. This annexure covers the requirements of deformed steel bars and wires for use as reinforcement in concrete, in the following three strength grades:

(a) Fe 415, (b) Fe 500, and (c) Fe 550

Note: The figures following the symbol Fe indicates the specified minimum 0.2 percent proof stress or yield stress in N/mm².

2. Glossary of terms

2.1. **Batch** – Any quantity of bars / wires of same size and grade whether in coils or bundles presented for examination and test at one time.

2.2. **Bundle** – Two or more coils or a number of lengths properly bound together.

2.3. **Elongation** - The increase in length of a tensile test piece under stress. The elongation at fracture is conventionally expressed as a percentage of the original gauge length of a standard test piece.

2.4. **Longitudinal rib** – A rib of uniform cross-section, parallel to the axis of the bar/wire (before cold working, if any).

2.5. **Nominal diameter or size** - The diameter of a plain round bar/wire having the same mass per metre length as the deformed bar / wire.

2.6. **Nominal perimeter of a deformed bar/wire** – 3.14 times the nominal diameter.

2.7. **Nominal mass** – The mass of the bar / wire of nominal diameter and of density 0.007 kg/mm² per metre run.

2.8. **0.2 Percent proof stresses** – The stress at which a non-proportional elongation equal to 0.2 percent of the original gauge length takes place.

2.9. **Tensile strength** – The maximum load reached in a tensile test divided by the effective cross sectional area of the gauge length portion of the test piece, also termed as ultimate tensile stress.

2.10. **Transverse rib** - Any rib on the surface of a bar wire other than a longitudinal rib.

2.11. **Yield stress** - Stress (that is, load per unit cross-sectional area) at which elongation first occurs in (lie test piece without increasing the load during tensile test. In the case of steels with no such definite yield point, proof stress shall be applicable.

3. Manufacture and chemical composition

3.1. Steel shall be manufactured by the open hearth, electric, duplex, basic oxygen, or a combination of these processes. In case the manufacturer employs any other process, prior approval of the purchaser should be obtained.

3.1.1. Steel shall be supplied semi-killed or killed.

3.1.2. The bars/wires shall be manufactured from properly identified heats of mould cast, continuously cast steel or rolled semis.

3.1.3. The steel bars/wires for concrete reinforcement shall be manufactured by the process of hot-

rolling. It may be followed by a suitable method of cooling and/or cold working.

3.2. Chemical composition - The ladle analysis of steel when made as per relevant parts of IS: 228 shall be as follows:

Constituent	Percent, maximum		
	Fe 415	Fe 500	Fe 550
Carbon	0.30	0.30	0.30
Sulphur	0.060	0.055	0.055
Phosphorus	0.060	0.055	0.050
Sulphur and phosphorus	0.11	0.105	0.10

Note: 1) For guaranteed weldability, the percentage of carbon shall be restricted to 0 -25 percent, maximum.

Note: 2) Addition of micro alloying elements is not mandatory for any of the above grades. When strengthening elements like Nb, V, B and Ti are used individually or in combination, the total contents shall not exceed 0-30 percent; in such case manufacturer shall supply the purchaser or his authorized representative a certificate stating that the total contents of the strengthening elements in the steel do not exceed the specified limit.

3.2.1. In case of product analysis, the permissible variation from the limits specified under 3.2 shall be as follows:

Constituent	Variation, over specified maximum limit, percent, max
Carbon	0.02
Sulphur	0.005
Phosphorus	0.005
Sulphur and phosphorus	0.010

3.2.2. For welding of cold-worked deformed bars, the recommendations of IS: 9417-1979 shall be followed.

3.2.3. In case of deviations from the specified maximum, two additional test samples shall be taken from the same batch and subjected to the test or tests in which the original sample failed. Should both additional test samples pass the test, the batch from which they were taken shall be deemed to comply with this standard. Should either of them fail, the batch shall be deemed not to comply with this standard.

3.3. Rolling and cold-working of bars/wires

3.3.1. All bars/wires shall be well and cleanly rolled and shall be round and free from surface defects and pipe, or oilier defects detrimental to its subsequent processing and to its end use. Rust, seams, surface irregularities or mill scale shall not be the cause for rejection provided hard wire brushed test specimen fulfils all the requirements of this specification.

3.3.2. Stretching may or may not be combined with cold working. The unworked length at each end of the bar/wire shall not exceed 100 mm or 4 times the nominal diameter, whichever is greater.

4. Requirements for bond

4.1. High strength deformed bars/wires shall satisfy the requirements given in either 4.2 or 4.7.

4.2. **Deformation and surface characteristics** - For high strength deformed bars/wires, the mean area of ribs (in mm^2) per unit length (in mm) above the core of the bar/wire, projected on a plane normal to the axis of the bar/wire calculated in accordance with 4.4 shall not be less than the following values: 0.12ϕ for ≤ 10 mm, 0.15ϕ for $10 \text{ mm} < \phi \leq 16$ mm, 0.17ϕ for $\phi > 16$ mm, where ϕ is the nominal diameter of bar/wire in mm.

The mean projected area of transverse ribs alone shall be not less than one-third of the values given above.

4.3. The ribs contributing to the projected area considered in 4.2 shall consist of:

- a) Longitudinal ribs in the form of continuous or discontinuous helix; and
- b) Transverse ribs which after hot-rolling or cold-working are uniform in size and shape along the length of the hardwire, and are spaced along the bar/wire at substantially uniform distances.

4.4. The mean projected rib area per unit length A_r (in mm^2 per mm) may be calculated from the following formula : Where

$$A_r = \frac{n_{tr} A_{tr} \sin O}{s_{tr}} + \frac{m_r d_{tr} \pi \phi}{s_p}$$

n_{tr} = number of rows of transverse ribs ;

A_{tr} = area of longitudinal section of a transverse rib on its own axis (see Fig.1) in mm^2

O = including of the transverse rib to the bar axis (after twisting for cold – worked twisted bars) in degrees. Average value of two ribs from each row of transverse ribs shall be taken;

s_{tr} = spacing of transverse ribs in mm ;

m_r = number of longitudinal ribs;

d_{tr} = height of longitudinal ribs in mm ;
= nominal diameter of the bar / wire in mm ; and

s_p = pitch of the twist in mm.

Note: 1. In the case of hot rolled bars / wires which are not subjected to cold twisting, the value of s_p in the second term of the expression for A_r shall be taken as infinity rendering the value of the second term to zero.

Note: 2. A_{tr} may be calculated as $2/3 l_{tr} d_{tr}$ where l_{tr} and d_{tr} are shown in Fig.1

Note3. In the case of cold – worked bars / wires with some discontinuous longitudinal ribs, the number of longitudinal ribs, n_{1r} shall be calculated as an equivalent number using the following formula and accounted for in the expression for A_r :

$$m_r \frac{m_r l_{tr} d_{tr}}{s_{1r} d_{tr}} + \text{Number of continuous longitudinal ribs}$$

Where

m_r' = number of discontinuous longitudinal ribs,

l' = average length of discontinuous longitudinal ribs

d_{tr}' = height of discontinuous longitudinal ribs

s_{tr}' = averaged spacing of discontinuous longitudinal ribs, and

d_{tr} = height of continuous longitudinal ribs.

Note: 4. The average length of discontinuous longitudinal ribs shall be determined by dividing a measured length of the bar equal to at least 10ϕ by the number of discontinuous longitudinal ribs in the measured length, ϕ being the nominal diameter of the bar. The measured length of the bar shall be the distance from the center of one rib to the center of another rib.

4.5. The heights of longitudinal and transverse ribs shall be obtained in the following manner

a) The average height of longitudinal ribs shall be obtained from measurements made at not less than 4 points, equally spaced, over a length of 10ϕ or pitch of rib, whichever is greater.

b) The height of transverse ribs shall be measured at the centre of 10 successive transverse ribs.

4.6. The average spacing of transverse ribs shall be determined by dividing a measured length of the bar / wire equal to at least 10ϕ by the number of spaces between ribs in the measured length, ϕ being the nominal diameter of the bar / wire. The measured length of the bar / wire shall be the distance from the centre of one rib to the centre of another rib.

4.7. When subjected to pull-out test the bond strength calculated from the load at a measured slip of 0.025 mm and 0.25mm for deformed bars / wires shall exceed that of a plain round bar of the same nominal size by 40 percent and 80 percent respectively.

4.7.1. The pull-out test shall be conducted in accordance with IS: 2770 (part 1)-1967* unless otherwise modified.

4.7.2. Bonded length of the bar embedded in the concrete shall be 5 times the diameter of the bar; the rest of the embedded length shall be made unbounded by providing plastic sleeve for that portion.

5. Nominal sizes

5.1. The nominal sizes of bars / wires shall be as follows :

Nominal size, 4,5,6,7,8,10,12,16,18,20,22,25,28,32,36,40,45 and 50mm.

Note: Other sizes may also be supplied by mutual agreement.

5.2. The exact values for the cross-sectional area and nominal masses of individual bars / wires, shall be as given in Table 1.

5.3. **Effective cross** – sectional area of deformed bars and wires

5.3.1. For bars / wires whose pattern of deformation is such that by visual inspection, the cross-sectional area is substantially uniform along the length of the bar / wire, the effective cross-sectional area shall be the gross sectional area determined as follows, using a bar / wire not less than 0.5 m in length :

$$\frac{W}{0.00785L}$$

$$\frac{1.03 w'}{0.00785 L}$$

Gross cross sectional area in mm² =

Where

W = mass in kg weighed to a precision of ± 0.5 percent, and

L = length in m measured to a precision of ± 0.5 percent.

5.3.2. For a bar / wire whose cross – sectional area varies along its length, a sample not less than 0.5 in long shall be weighed (w) and measured to a precision of ± 0.5 percent in the as rolled and / or cold – worked condition, and after the transverse ribs have been removed, it shall be re-weighed (w').

The effective cross-sectional area shall then be round as follows:

Table d1 cross sectional area and mass (clause 5.2)

Nominal sized	Cross sectional area	Mass per meter
Mm	Mm ²	kg
1	2	3
4	12.6	0.099
5	19.6	0.154
6	28.3	0.222
7	38.5	0.302
8	50.3	0.395
10	78.6	0.617
12	113.1	0.888
16	201.2	1.58
18	254.6	2.00
20	314.3	2.47
22	380.3	2.98
25	491.1	3.85
28	616.0	4.83
32	804.6	6.31
36	1018.3	7.99
40	1257.2	9.85
45	1591.1	12.50
50	1964.3	15.42

a) Where the difference between the two masses (w – w ') is less than 3 percent of w ' , the effective cross-sectional area shall be obtained as in 5.3.1., b) Where the difference is equal to or greater than 3 percent, the effective cross-sectional area in mm² shall be taken as:

Where

W ' = mass in kg of the bar with transverse ribs removed, and L = length in m.

For routine test purposes, a nominal ratio of effective to gross cross-sectional area of bars / wires covered by (b) shall be declared and used by the manufacturer.

6. Tolerances on dimensions and nominal mass

6.1. **Specified lengths** - If bars / wires are specified to be cut to certain lengths, each bar / wire shall be cut within deviations of ± 75 25 mm on the specified length, but if minimum lengths are specified, the deviations shall be + 50mm and – 0 mm.

6.2. Nominal mass

6.2.1. For the purpose of checking the nominal mass, the density of steel shall be taken as 0.007 85 kg /mm² of the cross-sectional area per metre run.

6.2.2. Unless otherwise agreed to between the manufacturer and the purchaser, the tolerances on nominal mass shall be as in Table 2. For bars / wires whose effective cross-sectional areas is determined as in 5.3.2 (b), the nominal mass per metre run shall correspond to the gross mass and the deviations in Table 2 shall apply to the nominal mass.

Table 2 Tolerances on nominal mass

Nominal size Mm	Tolerance on the nominal mass, percent		
	Batch	Individual sample*	Individual sample for coils only†
Up to and including 10	± 7	- 8	± 8
Over 10 up to and including 16	± 5	- 6	± 6
Over	± 3	- 4	± 4

* For individual sample plus tolerance is not specified.

† For coils batch tolerance is not applicable.

6.2.3. The nominal mass per metre of individual sample, batch and soil shall be determined as given in 6.2.3.1 to 6.2.3.3.

6.2.3.1. **Individual sample** – The nominal mass of an individual sample shall be calculated by determining the mass of any individual sample taken at random as specified in 10.1 and dividing the same by the actual length of the sample. The sampled shall be of length not less than 1.5 meter.

6.2.3.2. **Batch** – The nominal mass of a batch shall be calculated from the mass of the test specimens taken as specified in 10.1 and dividing the same by the actual total length of the specimens. Each specimen shall be of length not less than 0.6 meter.

6.2.3.3. **Coils** – The nominal mass of a coil shall be calculated by determining the mass of two samples of minimum one meter length taken from each end of the coil and dividing the same by the actual total length of the samples.

7. Physical properties

7.1. Proof stress, percentage elongation and tensile strength for all sizes of deformed bars / wires determined on effective cross – sectional area (see 5.3) and in accordance with 8.2 shall be specified in Table 3.

Table 3 Mechanical properties of high strength deformed bars and wires

Sl. No.	Property	Grade		
		Fe 415	Fe 500	Fe 550
1	0.2 percent proof stress / yield	415.0	500.0	550.0

	stress, Min, N/mm ²			
2	Elongation, percent, Min, on gauge length $5.65 \sqrt{A}$, where A is the cross-sectional area of the test piece	14.5	12.0	8.0
3	Tensile strength, Min	10 percent more than the actual 0.2 percent proof stress but not less than 485.0 N/mm ²	8 percent more than the actual 0.2 percent proof stress but not less than 545.0 N/mm ²	6 percent more than the actual 0.2 percent proof stress but not less than 585.0 N/mm ²

7.2. The bars / wires shall withstand the bend test specified in 8.3 and the rebend test specified in 8.4

7.3. **Bond** – Bars / wires satisfying the requirements given in 4 shall be deemed to have satisfied the bond requirements of a deformed bar / wire.

8. Tests

8.1. Selection and preparation of test sample – Unless otherwise specified in this standard, the requirements of IS: 226-1975 shall apply.

8.1.1. All test pieces shall be selected by the purchaser or his authorised representative, either;

(a) from the cuttings of bars / wires ; or (b) if, he so desires, from any bar / wire after it has been cut to the required or specified size and the test piece taken from any part of it. In neither case, the test piece shall be detached from the bar / wire except in the presence of the purchaser or his authorised representative.

8.1.2. The test pieces obtained in accordance with 8.1.1 shall be full sections of the bars / wires and shall be subjected to physical tests without any further modifications. No reduction in size by machining or otherwise shall be permissible, except in case of bars of size 28mm and above (see 8.1.2.1.

8.1.2.1. No test piece shall be annealed or otherwise subjected to heat treatment except as provided in 8.1.3 Any straightening which a test piece may require shall be done cold.

8.1.3. Notwithstanding the provisions in 8.1.2 test pieces may be subjected to artificial ageing at a temperature not exceeding 100^o C and for a period not exceeding 2 hours.

8.1.4. Before the test pieces are selected, the manufacturer or supplier shall furnish the purchaser or his authorised representative with copies of the mill records giving the mass of bars / wires from that cast can be identified.

8.2. **Tensile test** - The tensile strength, 0.2 percent proof stress and percentage elongation of bars / wires shall be determined in accordance with requirements of IS: 1608-1972 read in conjunction with IS : 226-1975

8.2.1. Alternatively and by agreement between the purchaser and the supplier, for routine testing, the proof stress may be determined in conjunction with the tensile strength test and may be taken as the stress measured on the specimen whilst under load corresponding to an increase measured by an extensometer of 0.4 percent for Fe 415 bars / wires, 0.45 percent for grade Fe 500 bars / wires and 0.47 percent for grade Fe 550 bars / wires the total strain on any convenient gauge length.

8.2.2. The stresses shall be calculated using the effective cross – sectional area of the bar / wire.

8.3. **Bend best** - The bend test shall be performed in accordance with the requirements of IS: 1599 – 1974 and the mandrel diameter shall be considered to have passed the test if there is no transverse crack in the bent portion.

Table 4 mandrel diameter for bend test

Nominal size mm	Mandrel diameter for different grades		
	Fe 415	Fe 500	Fe 550
Up to and including 22	3 Ø	4 Ø	5 Ø
Over 22	4 Ø	5 Ø	6 Ø

Where Ø is the nominal size in mm of the test piece.

8.4. **Rebend test** - The test piece shall be bent to an included angle of 135° (see Fig.2) using a mandrel of appropriate diameter (see 8.4.1) The bent piece shall be aged by keeping in boiling water (100° C) for 30 minutes and then allowed to cool. The piece shall then be bent back to have an included angle of 157½°. The specimen shall be considered to have passed the test if there is no fracture in the bent portion.

8.4.1 The diameter of the mandrel shall be as given below:

Nominal size of specimen	Dia of mandrel for Fe	
	415 and Fe 500	550
Up to and including 10 mm	5 Ø	7 Ø
Over 10 mm	7 Ø	8 Ø

8.5. **Retest** - Should any one of the test pieces first selected fail to pass any of the tests specified in this standard, two further samples shall be selected for testing in respect of each failure. Should the test pieces from both these additional samples pass, the material represented by the test samples shall be deemed to comply with the requirements of that particular test. Should the test piece from either of these additional samples fail, the material presented by the samples shall be considered as not having complied with this standard.

9. Routine inspection and testing

9.1. All material shall be subject to routine inspection and testing by the manufacturer or supplier in accordance with this standard and a record of the test results of material conforming to this standard shall be kept by the manufacturer or the supplier. The records shall be available for inspection by the purchaser or his representative.

In the case of material delivered to a supplier, the manufacturer shall supply a certificate containing the results of all the required tests on samples taken from the delivered material.

10. Selection of test specimens

10.1. For checking nominal mass, tensile strength, bend test and rebend test, test specimen of sufficient length shall be cut from each size of the finished bar / wire at random at a frequency not less than that specified in Table 5.

Nominal size	Quantity	
	For casts / heats below 100	For casts / heats over 100

	tonnes	tonnes
Under 10 mm	1 Sample from each 25 tonnes or part thereof	1 Sample from each 40 tonnes or part thereof
10 mm to 16 mm inclusive	1 Sample from each 35 tonnes or part thereof	1 Sample from each 45 tonnes or part thereof
Over 16 mm	1 Sample from each 45 tonnes or part thereof	1 Sample from each 50 tonnes or part thereof

10.2. **Bond test** - The frequency of bond test as required in 4.7 shall be as agreed to between the manufacturer and the purchaser / testing authority.

11. Delivery, inspection and testing facilities

11.1. Unless otherwise specified, general requirements relating to the supply of material, inspection and testing shall conform to IS: 1387-1968. {General requirements for the supply of metallurgical materials (first revision)}

11.2. No material shall be dispatched from the manufacturer's or supplier's premises prior to its being certified by the purchaser or his authorized representative as having fulfilled the tests and requirements laid down in this standard except where the bundle containing the bars / wires is marked with the ISI certification mark.

11.3. The purchaser or his authorised representative shall be at liberty to inspect and verify the steel maker's certificate of cast analysis at the premises of the manufacturer or the supplier. When the purchaser requires an actual analysis of finished material, this shall be made at a place agreed to between the purchaser and the manufacturer or the supplier.

11.4. **Manufacturer's certificate** - In the case of bars/wires which have not been inspected at the manufacture's works, the manufacturer or supplier, as the case may be, shall supply the purchaser or his authorized representative with the certificate stating the process of manufacture and also the test sheet signed by the manufacturer giving the result of each mechanical test applicable to the material purchased and the chemical composition, if required. Each test sheet shall indicate the number of the cast to which it applies, corresponding to the number or identification mark to be found on the material.

12. Identification and marking

12.1. The manufacturer or supplier shall have ingots, billets and bars or bundles of bars / wires marked in such a way that all finished bars / wires can be traced to the cast from which they were made. Every facility shall be given to the purchaser or his authorized representative for tracing the bars/wires to the cast from which they were made.

12.2. For each bundle / coil of bars / wires a tag shall be attached indicating cast No. / lot No., grade and size.

12.3. Distinguishing mark shall be given to identify the different grades of bar / wire.

12.3.1. Identification marks like brand name, trade mark etc., that are introduced during rolling shall be designed and located in such a manner that the performance in use of the bar is not affected.

12.3.2. Each bundle containing the bars / wires may also be suitably marked with the ISI certification mark in which case the concerned test certificate shall also bear the ISI certification mark.

Note - The use of the ISI certification mark is governed by the provisions of the Indian standards institution (certification marks) act and the rules and regulations made there under. The ISI mark on products covered by an Indian standard conveys the assurance that they have been produced to comply with the requirements of that standard under a well-defined system of inspection, testing and quality control which is devised and supervised by ISI and operated by the producer. II marked products are also continuously checked by ISI for conformity to that standard as a further safeguard. Details of conditions under which a license for the use of the ISI certification mark may be granted to manufacturers or processors, may be obtained from the Indian standards institutions.

SECTION V

DRAWINGS

Brief Description of drawing

The Works are shown in the following drawings that are issued as a part of the Tender Documents:

Sl. No	Drawing No.	Description
1	22/164-LP	LOCATION PLAN
2	22/164-02	BERTH No 2 PLAN
3	22/164-03	CROSS SECTION
4	22/164-04	CROSS SECTION OF BERTH SURFACE
5	22/164-05	DWARF WALL
6	22/164-06	PLAN OF BERTHS

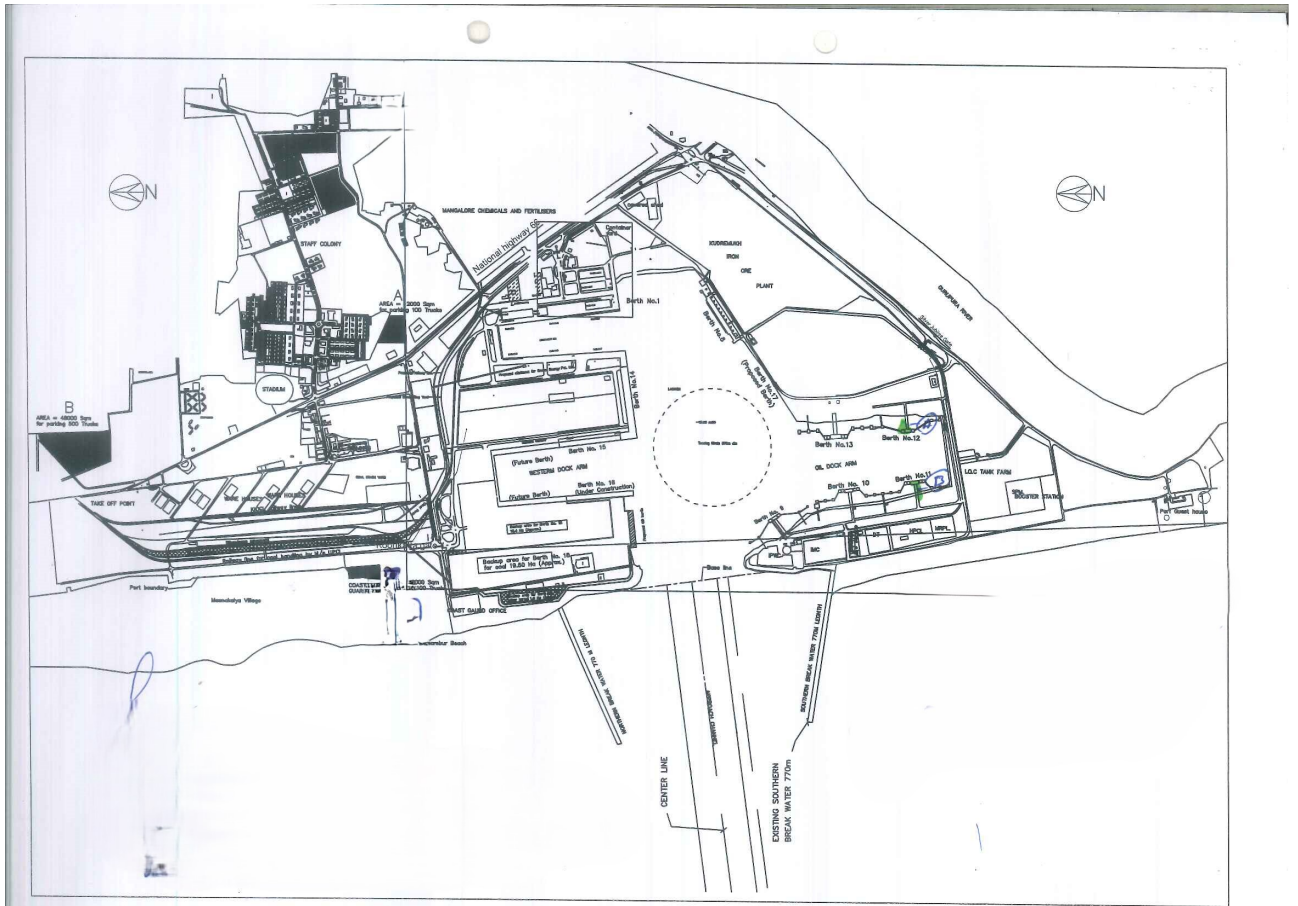

1	22/164-LP	LOCATION PLAN
---	-----------	---------------

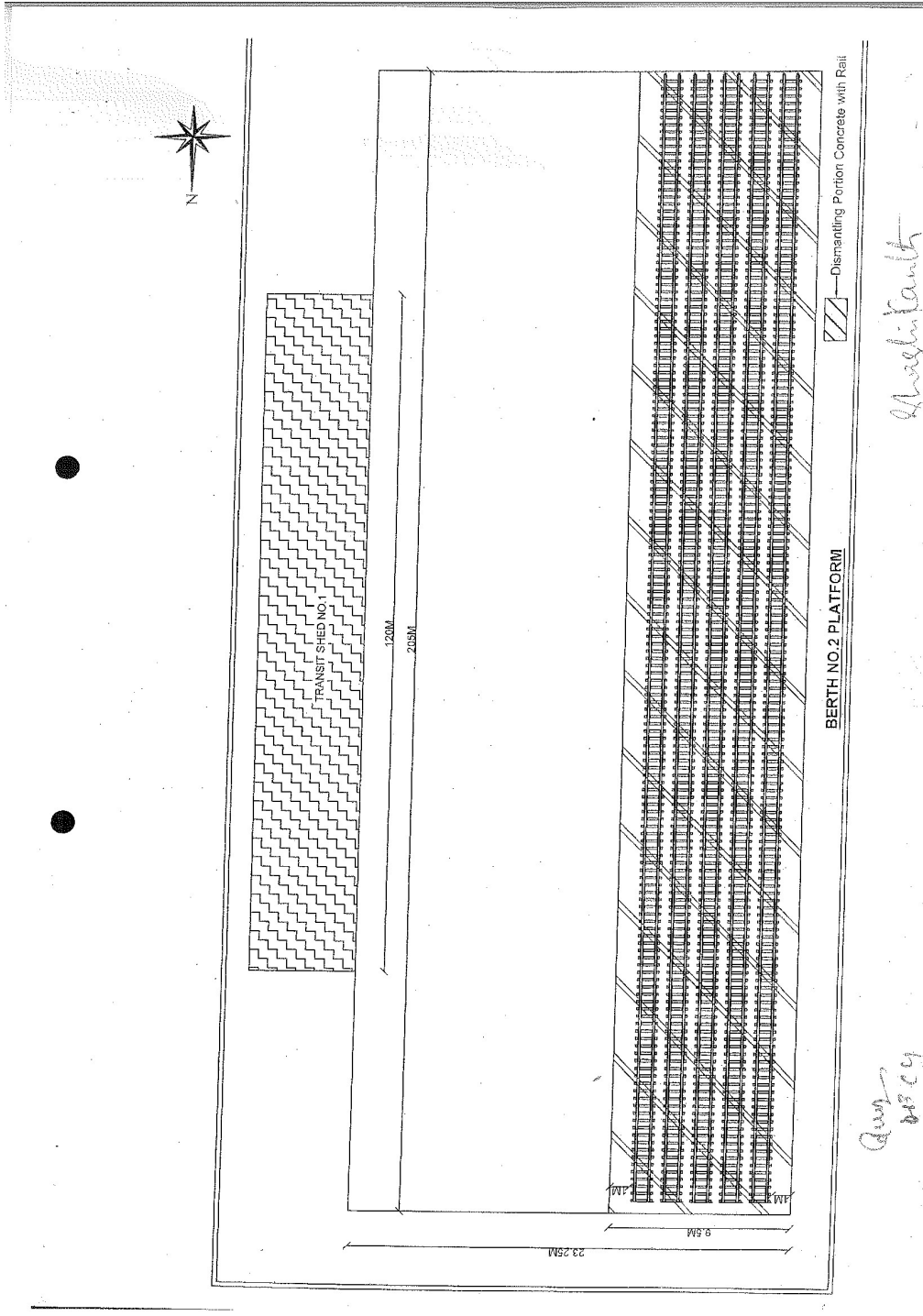

2	22/164/-01	BERTH No 2 PLAN
---	------------	-----------------

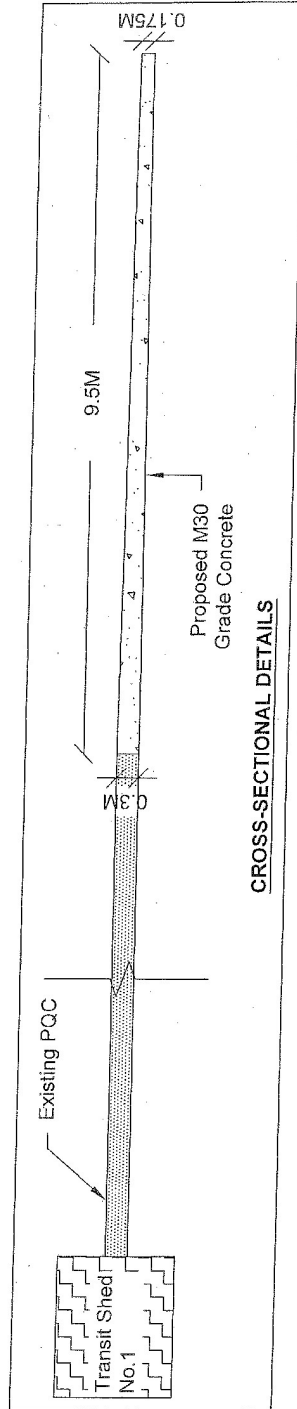

Shreshth Parth

*Prady
b/c c/c*

3	22/164-03	CROSS SECTION
---	-----------	---------------

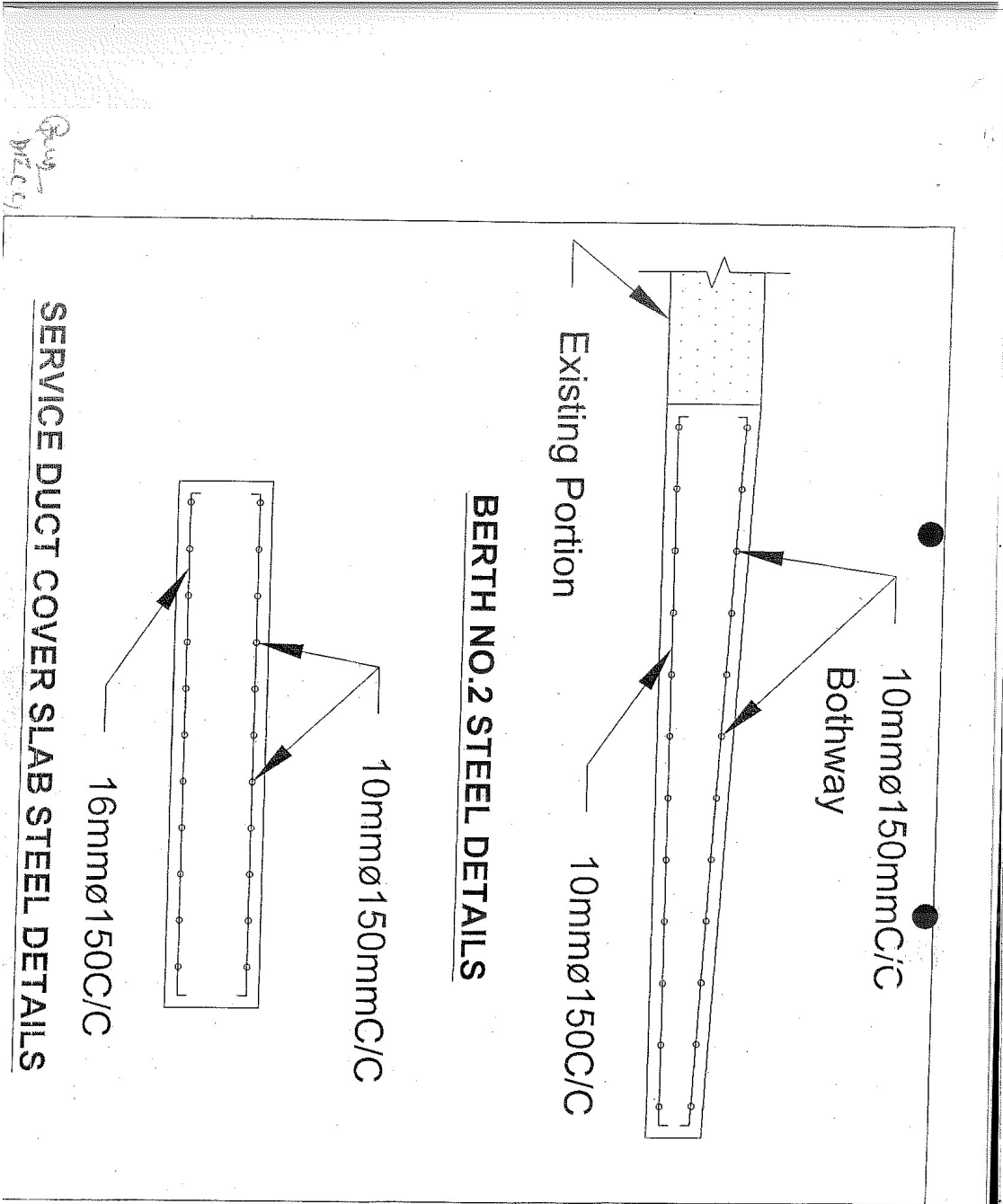

4	22/164-04	CROSS SECTION OF BERTH SURFACE
---	-----------	--------------------------------

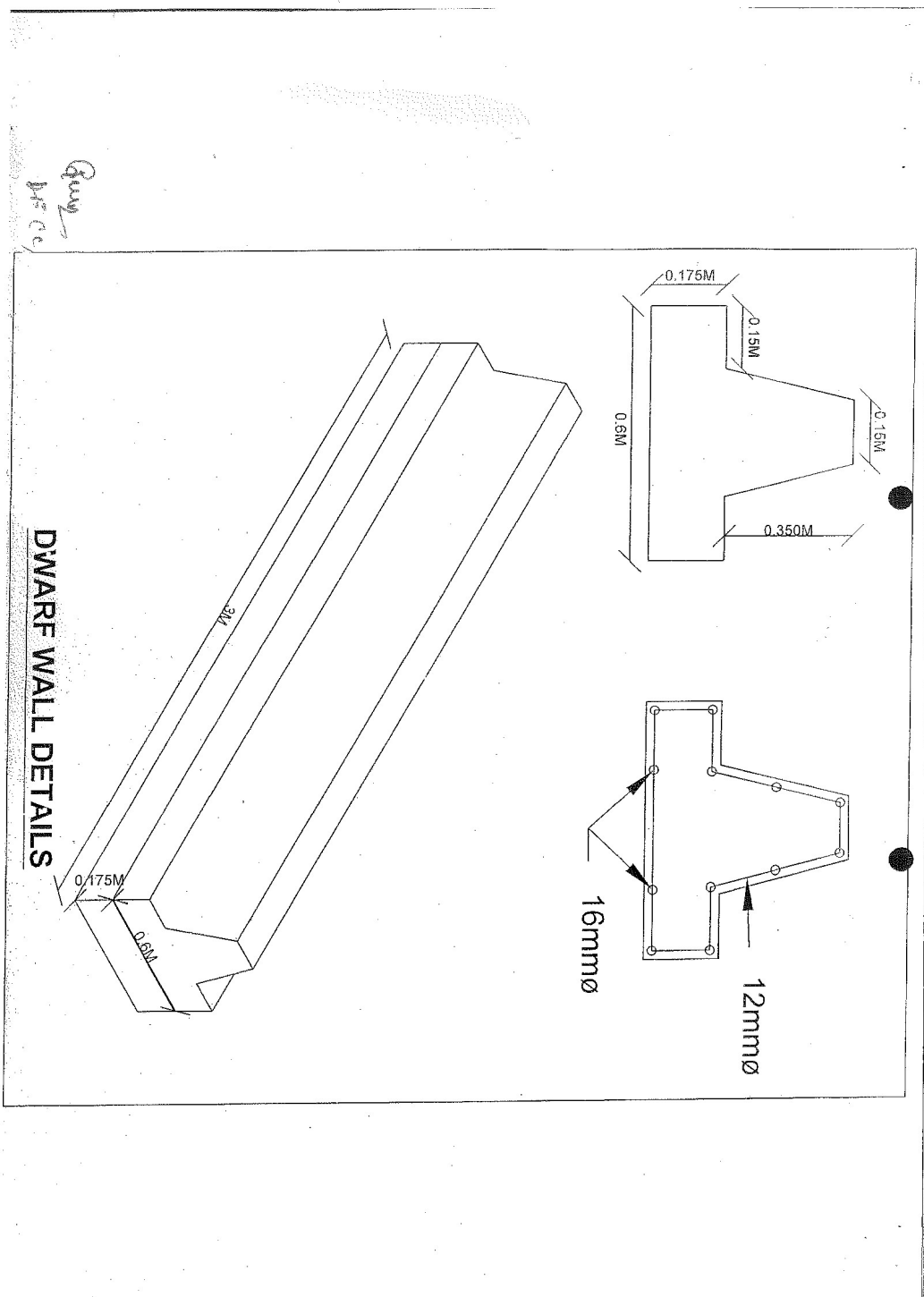

5	22/164-05	DWARF WALL
---	-----------	------------

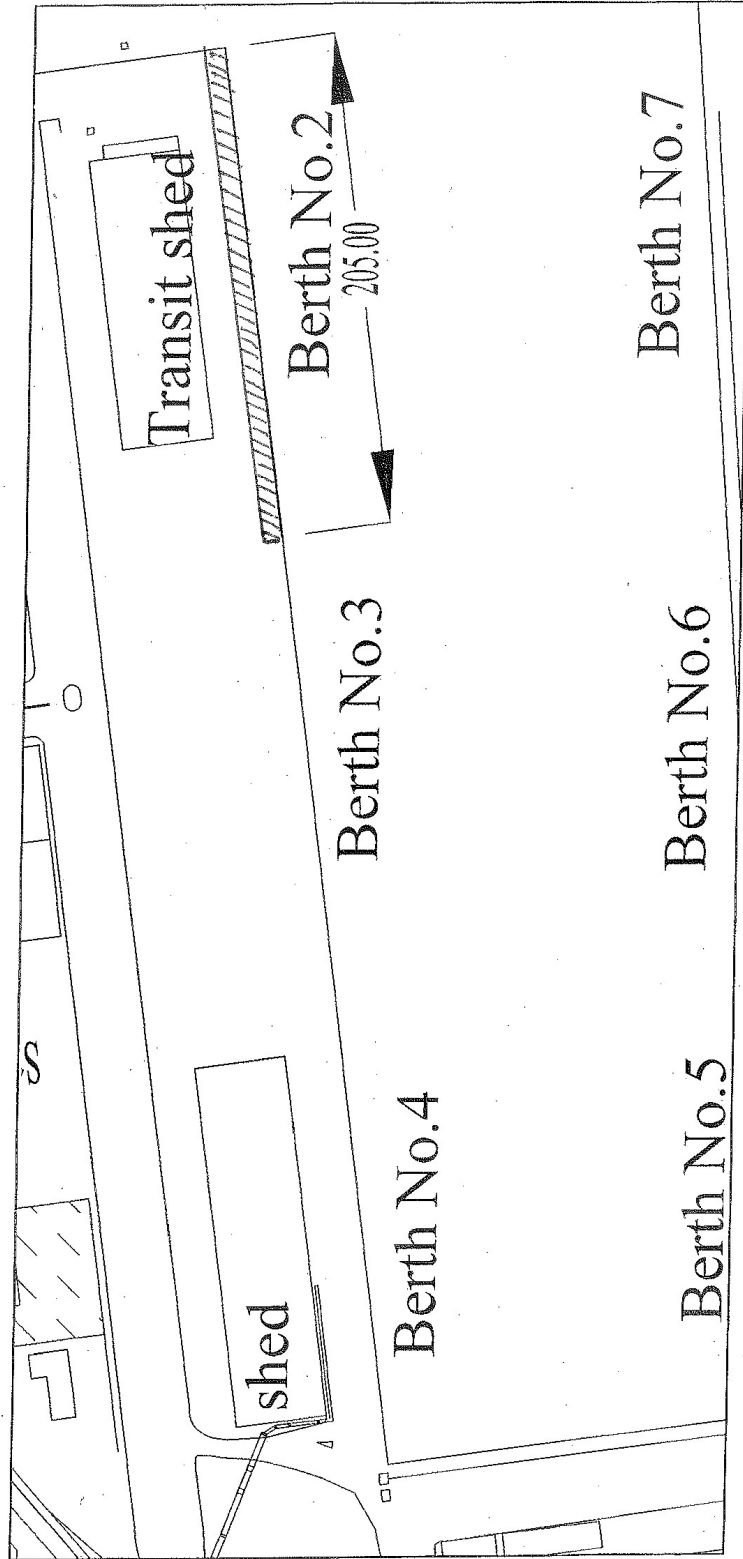

LOCATION

RAY
DEC 04

6	22/164-06	PLAN OF BERTHS
---	-----------	----------------



**NEW MANGALORE PORT AUTHORITY
Panambur, Mangalore**

**“PROVIDING M30 GRADE CONCRETE FOR REMAINING PORTION OF BERTH
NO. 2 INSIDE WHARF AREA”**

**TENDER DOCUMENT
Volume - III**

BILL OF QUANTITIES

Table of Contents

SECTION VI.....	202
(i) PREAMBLE TO BILL OF QUANTITIES	202
1. General Instructions.....	202
2. Civil Works.....	204
3. Abbreviations.....	206
ii) BILL OF QUANTITIES.....	208
(iii) FORM OF TENDER	210
SECTION VII.....	212
SCHEDULE – A	212
ROYALTY	212
SCHEDULE – B	217

VOLUME III**SECTION VI****(i) PREAMBLE TO BILL OF QUANTITIES****1. General Instructions****1.1 General**

- 1.1.1 This Bill of Quantities must be read with the Drawings, Conditions of Contract and the Specifications, and the Contractor shall be deemed to have examined the Drawings, Specifications, Conditions of Contract and to have acquainted himself with the detailed descriptions of the Works to be done, and the way in which they are to be carried out.
- 1.1.2 Notwithstanding that the work has been sectionalized every part of it shall be deemed to be supplementary to and complementary of every other part and shall be read with it or into it so far as it may practicable to do so.
- 1.1.3 The detailed descriptions of work and materials given in the Specifications are not necessarily being repeated in the Bill of Quantities.
- 1.1.4 The Contractor shall be deemed to have visited the Site before preparing his tender and to have examined for himself the conditions under which the work will proceed and all other matters affecting the carrying out of the works and cost thereof.
- 1.1.5 The Tenderer will be held to have familiarized himself with all local conditions, in so far as they affect the work, means of access and the locality of existing services, in order to execute the Works measured and described hereinafter. No claims for want of knowledge in this respect will be reimbursed.

1.2 Rates and Prices to be Inclusive

- 1.2.1 Rates and prices set against items are to be the all-inclusive value of the finished work shown on the Drawings and/or described in the Specification or which can reasonably be inferred there from and are to cover the cost of provision of plant, labour, supervision, materials, test charges, freight, transportation, erection, installation, performance of work, care of works, insurance, maintenance, overheads and profits and every incidental and contingent cost and charges whatsoever including taxes if any excluding GST including every kind of temporary work executed or used in connection therewith (except those items in respect of which provision has been separately made in the general condition of contract) and all the Contractor's obligations under the Contract and all matters and things necessary for the proper completion and maintenance of the Works.
- 1.2.2 The rates and prices set down against the items are to be the full inclusive value of the finished work shown on the Drawing and/or described in the Specification or which can reasonably be inferred the reform and to cover the cost of every description of Temporary Works executed or used in connection therewith (except those items in

respect of which specific provision has been separately made in these Bills of Quantities) and all the Contractor's obligations under the Contract including testing, giving samples and all matters and things necessary for the proper execution, completion and maintenance of the Works.

- 1.2.3 The Specifications are intended to cover the supply of material and the execution of all work necessary to complete the works. Should there be any details of construction or material which have not been referred to in the Specifications or in the Bill of Quantities and Drawings, but the necessity for which may reasonably be implied or inferred there from, or which are usual or essential to the completion of all works in all trades, the same shall be deemed to be included in the rates and prices entered in the Bill of Quantities. The rates and prices are to cover the item as described in the Bill of Quantities and if there is inconsistency in the description between the Bill of Quantities, Specifications or Drawings, the interpretation will be done according to General Conditions of Contract.
- 1.2.4 The quantities given in the Bill are approximate and are given to provide a common basis for tendering. They are not to be taken as a guarantee that the quantities scheduled will be carried out or required or that they will not be exceeded. The Employer / Engineer reserves the right to delete any item and / or increase / reduce quantities indicated in the Bills of Quantities at any time. Payment will be made according to the actual quantities of work ordered and carried out in the contract. However, the rates quoted shall be valid for any extent of variation in quantity of each individual item provided that the total contract value does not get altered by more than indicated in conditions of contract. No claim whatsoever for extra payment due to variation of quantities within the above said limit would be entertained.
- 1.2.5 The drawings for tender purposes are indicative only of the work to be carried out. However, the Tenderer must allow within his price for the items of work included in the Tender Documents for the details which will appear on subsequent drawings developed for construction purposes. Rate and price shall include any additional design/ detailing to be carried out by contractor.
- 1.2.6 The rates and prices shall include (except where separate items are given) for the provision and operation of the following items, for compliance with the Conditions of Contract, Special Conditions, the specifications and Tender drawings:
- i) Supervision and labour for the Works;
 - ii) All materials, installation/erection, handling and transportation;
 - iii) All Contractor's Equipment;
 - iv) All testing, commissioning, insurance, maintenance, security, welfare facilities, overheads and profit and every incidental and contingent costs and charges whatsoever including;
 - v) All temporary fencing, watching, lighting, sanitary accommodation, general security arrangements, welfare facilities and first aid provision;
 - vi) Provision and maintenance of Contractor's site offices, cabins, huts, maintenance and storage areas;
 - vii) Taxes if on the transfer of property in goods in the execution of works, other than GST, Customs Duty for materials to be permanently incorporated into the Works);

- viii) All necessary temporary services including fresh water, compressed air lines, electrical cabling and switchgear, telephone, walkie-talkie and facsimile facilities;
- ix) The maintenance of all Contractor's services;
- x) All insurances for the Works;
- xi) Allowance for complying with all environmental aspects as specified;
- xii) Detail design of components of temporary works, wherever necessary as directed by Engineer.

1.4 Method of Measurement

1.4.1 Measurement of Work shall be in accordance with IS 1200 and shall be net off the dimensions of the works shown on the drawings except as mentioned below:

1.4.2 Units of Measurement: The units of measurement used in this Bill of Quantities are in metric units as follows:

- i) Linear: Linear metre, centimeter or millimeter abbreviated to 'Rm', 'cm' or 'mm' respectively.
- ii) Superficial: Square metre or Square centimeter abbreviated to 'Sq.M' or 'sq.cm' respectively.
- iii) Volumetric: Cubic metre abbreviated to 'cu.m'. Litre abbreviated to 'L'
- iv) Weight: Tonne = 1000 Kilograms, abbreviated to 'T', / 'MT' Kilogram abbreviated to 'kg'
- v) Numbers: Numbers abbreviated to Nos. or No.
- vi) Lump sum: Lump sum abbreviated to 'L.S.'

1.5 Currency

1.5.1 All monetary reference herein and the Bill of Quantities shall be priced in Indian Rupee Currency.

2. Civil Works

2.2 Precast Concrete

2.2.1 Shuttering for precast concrete shall not be measured and paid for separately.

2.2.2 Effort for placement of precast concrete at the final locations shall not be measured unless a specific item is provided in the Bill of Quantities.

2.2.3 The precast concrete units shall be measured as shown on the detailed drawings.

2.3 In-situ Concrete

2.3.1 Shuttering for In-situ concrete shall not be measured and paid for separately.

2.3.2 No deduction will be made for chamfers smaller than 50 sq.cm. sectional area, reinforcement bolts and other embedded parts unless larger than 0.1 sq.m. sectional area and 0.03 cu.m. in volume. No extra volume will be measured for splays or fillets smaller than 50 sq.cm. sectional area.

- 2.3.3 The rates for reinforced concrete shall include for all batching, mixing, transporting, hoisting or lowering to any height / depth, placing in position and compaction in work of any sectional area or thickness including shuttering, forming necessary construction joints, shear keys and stop ends, and for curing and protecting etc. all as specified.
- 2.3.4 The rates shall include for preparing construction joints, shear keys and surfaces against which next stage concrete is to be cast and building in fittings including pipes and bolts except where specifically billed separately. No separate payment will be made for making openings/pockets/pits of any size and shape. Where surfaces are to receive finishes the rates shall include for leaving the surface rough or for hacking and roughening the surface to form a key.
- 2.3.5 Unless otherwise noted, rates shall include for inserting pipes and other inserts in position accurately, concreting while they are in position and also for protecting the same as the work proceeds.
- 2.3.6 Unless otherwise noted, the rates for concrete items shall include for finishing the top surface to levels and slopes and surface finish as specified. Rates for concrete shall include for finishing the slab to specified slope towards drains, etc.
- 2.4 Reinforcement
- 2.4.1 Steel reinforcement will be measured by weight and fixed in accordance with Drawings and Specifications. The weight of reinforcement bars -whether plain, deformed or ribbed etc., -of various diameters will be calculated in accordance with Table 1 of IS:1732 'Dimensions for Round and Square Steel Bars for Structural and General Engineering Purposes'.
- 2.4.2 The rates shall include for cutting, welding laps, and waste, straightening short and long lengths, bending, fixing, rolling margin and the provision of spacer bars or support, chairs, binding wire, saddles, forks and all dense concrete spacer blocks, etc., including preparing bending schedules from the Drawings.
- 2.4.3 The rates shall include for all necessary descaling, wire brushing and cleaning to remove all rust and mill scale, dirt, grease and other deleterious matter before fixing and whilst still exposed during construction.
- 2.5 Structural and Miscellaneous Steel work
- 2.5.1 Rates for structural steel work and iron work shall include supply, fabrication, delivery and erection/embedment in concrete at Site and all charges for welding, cutting, bending, bolting, site connections, fixing to foundations.
- 2.5.2 The rates for Structural Steelwork shall include:
i) Supply, fabrication, delivery and erection

- ii) Rolling margin, cutting and waste, weld metal, bolts, fixings and fittings
- iii) Hoisting, drilling, bolting or welding and fixing in the manner specified or indicated in the drawing
- iv) Fabrication drawings
- v) Welding trials and tests
- vi) Erection trials
- vii) Protective treatment (painting, hot dip galvanizing etc), including making good any damage if provided in the BOQ item.

2.5.3 Metalwork items are described in the Bills of Quantities and the Tenderer is to include for all the fittings, etc., described. All items shall include the necessary fabrication, joints, angles, intersections and ends, all bolts or fixing lugs, all hoisting and scaffolding required and casting in fixings or later cutting out or forming pockets for same, grouting, supporting and making good.

2.5.4 Rates are to include for all necessary scaffolding, working over water and at any height staging and hoisting and tarpaulin or other protective covers and the cleaning and removal of paint stains and spots, etc.

3.4.1 The Contractor's unit rates and prices shall include all equipment, apparatus, material indicated in the Drawings, and/or Specifications in connection with the item in question and also associated labour as well as all additional equipment, apparatus, material, consumables usually necessary to complete the system even though not specifically shown, described or otherwise referred to and also associated labour.

3.4.2 The rate for providing and fixing above items shall include all fittings, fixtures, base and sole plates, anchor bolts, including epoxy grouting, etc. all complete as specified, including the necessary additional supervision to ensure accurate alignment

3. Abbreviations

4.1.1 The following abbreviations are used in the Specifications and Bill of Quantities:

IS :	Indian Standard
BS :	British Standard
Qty. :	Quantity
mm :	Millimeters
cm :	Centimeters
M / m / MTR :	Meters
LM :	linear metre
LS :	lump sum
Rs. :	Rupees
P. :	Paise
Nos. :	Numbers
do :	Ditto
MS :	mild steel
T :	Tones
Kg :	Kilogram
EO :	Extra over (previous sum unless specified otherwise)
sq.m. /m ² /SQMT:	square metre
sq.cm. :	square centimeters
mm ² :	Square Millimetre

Cu.m/CUM. :	cubic meters
YST :	yield stress
dia :	Diameter
wt. :	Weight
Drg.No.:	drawing number
max. :	Maximum
min :	Minimum
approx :	Approximately
n.e.:	not exceeding
incl:	Including
circ:	Circular
set :	set / sets
c/c	centre to centre
@ :	at the rate of

ii) BILL OF QUANTITIES

NAME OF WORK: PROVIDING M30 GRADE CONCRETE FOR REMAINING PORTION OF BERTH NO. 2 INSIDE WHARF AREA					
Item No.	DESCRIPTION OF ITEM	QTY	UNIT	RATE IN Rs.	AMOUNT (Rs. Ps.)
1	Shifting of Dwarf wall to designated location as directed by the Department, including cost of transportation, loading and unloading charges, crane charges, truck charges, and all other incidental charges etc. complete	60.00	Nos	212.19	12,731.40
2	Demolishing cement concrete manually/ by mechanical means including disposal of material to the appropriate disposal area as per direction of Engineer-in-charge.	440.00	Cum	1663.00	7,31,720.00
3	Cutting and removing the existing Railway track of mixed gauge along with the check rails provided and to be stacked at the location as directed by the Engineer in Charge. The rates includes cost of exposing the rails, cutting, crane charges for lifting & transportation, and labour cost, Disposal of wooden sleepers etc., complete.	2000.00	RM	321.76	6,43,520.00
4	Providing and laying in position Reinforced cement concrete for all Super structures of building, Road works, Water works, Irrigation works & Super structure works of bridges up-to 3.50 m height. The granite/ trap/basalt crushed graded coarse aggregates and fine aggregates as per relevant IS Codes machine mixed with super plasticizers laid in layers, well compacted using needle vibrators. The cost includes all lead & lifts, cost of all materials, groove cutting, quality confirming to the requirements of relevant IS codes, labour, Usage charges of machinery, curing and all other appurtenances required to complete the work as per technical specifications including providing and removing formwork, centering & scaffolding, groove cutting charges. (The cost of steel reinforcement & dowel bars to be paid separately) M30 Design Mix Using 20 mm nominal size graded crushed coarse aggregates.	500.00	Cum	7357.35	36,78,675.00
5	Supplying, fitting and placing TMT FE 550 / 550D Steel Reinforcement including cost of all materials, machinery, labour, cleaning, straightening, cutting, bending, hooking, lapping/welding joints,	37.47	MT	86658.00	32,47,075.26

tying with binding wire / soft annealed steel wire and other ancillary operations complete as per drawing and technical specification.				
Total Rs.				83,13,721.66
Excess / Less (In percentage in two decimals)				
Quoted amount in Figures Rs.				

(Quoted amount - Rupees)

Note:

- 1) GST as applicable will be paid separately in the Tax invoice.
- 2) Contractor shall file the applicable returns with Tax department in time and submit the same as documentary evidence.

SIGNATURE OF THE BIDDER

(iii) FORM OF TENDER

NAME OF CONTRACT.....

To
The Chairman
New Mangalore Port Trust
Panambur
Mangalore - 575 010

Sir,

1. We have examined the Conditions of Contract, Specification, Drawings, Bill of Quantities, and Addenda Nos----- for the execution of the above-named Works, and we the undersigned, offer to execute and complete such Works and remedy any defects therein in conformity with the Conditions of Contract, Specifications, Drawings and Bill of Quantities and Addenda
2. We acknowledge that the Appendix forms part of our Tender.
3. We undertake, if our Tender is accepted, to commence the Works as soon as is reasonably possible after the receipt of the Engineer's notice to commence, and to complete the whole of the Works comprised in the Contract within the time stated in the Appendix to Tender.
4. We agree to abide by this Tender for the period of 120 days from the last date fixed for receiving the same and it shall remain binding upon us and may be accepted at any time before the expiration of that period.
5. Unless and until a formal Agreement is prepared and executed, this Tender together with your written acceptance thereof shall constitute a binding Contract between us.
6. We understand that you are not bound to accept the lowest or any tender you may receive.

Dated this _____ day of _____ 201 ____

Signature _____ in the Capacity of _____ duly

authorized to sign Tenders for and on behalf of _____

(IN BLOCK LETTERS)

Address: _____

Witnesses

1. Signature : _____

Name : _____

Address : _____

2. Signature : _____

Name : _____

Address : _____

SECTION VII
SCHEDULE – A
ROYALTY

SCHEDULE II

(See sub rule (1) of Rule 36)

Sl. No.	Name of the Mineral	Present Rate of Royalty	Royalty to be revised	
			Export	Domestic
1	Ornamental and Decorative Building Stones as defined under clause(m) of Rule 2 A) Dyke Rock (i) Black granites: (a) Chamarajanagar District:	15% of Sale Value or of Average Selling Price on advalorem basis or Rs.4,500 per m ³ which is higher.	Rs.1,200 per MT	Rs.600 per MT
	(b) All other Districts other than (a) above	15% of Sale Value or of Average Selling Price on advalorem basis or Rs.1,500 per m ³ which is higher.	Rs.1700 per MT	Rs.400 per MT
	(ii) Other varieties of dyke other than black granites (Entire State)	15% of Sale Value or of Average Selling Price on advalorem basis or Rs.1,500 per m ³ which is higher.	Rs.500 per MT	Rs.375 per MT
	(B)(i) Pink and Red Granites (Ilkal Pink Variety) (i) Hungunda and Badami Taluk of Bagalkot District, Kustagi of Koppal District.	15% of Sale Value or of Average Selling Price on advalorem basis or Rs.1,200	Rs.1,000 per MT	Rs.400 per MT
	(ii) Pink and Red Granites, Gneiss and their structural varieties (other than Ilkal Pink Variety)	15% of Sale Value or of Average Selling Price on advalorem basis or Rs.1,800 per m ³ which is higher	Rs.600 per MT	Rs.350 per MT
	C) Grey and White Granites and their varieties: (i) Very fine grained Grey granite (Siragrey Variety) Price on Chintanmi, Siddlaghatta of Chikkaballapura District Hoskote of Bangalore District.	15% of Sale Value or of Average Selling Price on advalorem basis or Rs.1,350 per m ³ which is higher.	Rs.500 per MT	Rs.350 per MT
	(ii) Grey and white granites and	15% of Sale Value or of	Rs.375 per	Rs.250 per

	textural varieties having shades of grey, balck and white colours (other than (i) above Entire State.	Average Selling Price on advalorem basis. Rs.1,050 per m3 which is higher.	MT	MT
	(iii) Grey granite of Devanahalli Taluk of Bangalore Rural District and Chikkaballapur Taluk of Chikkaballapur District	15% of Sale Value or of Average Selling Price on advalorem basis Rs.600 per m3 which is higher.	Rs.300 per MT	Rs.200 per MT
2	Felsite and its varieties suitable for use as Ornamental Stone- Entire State	15% of Sale Value or of Average Selling Price on advalorem basis Rs.1800 per m3 which is higher.	Rs.900 per MT	
3	Quartzite and sand stone and their varieties suitable for use as Ornamental Stone- Entire State	15% of Sale Value or of Average Selling Price on advalorem basis Rs.1800 per m3 which is higher.	Rs.900 per MT	
4	Marable and Crystalline Limestone as ornamental Stone- Entire State	15% of Sale Value or of Average Selling Price on advalorem basis Rs.1800 per m3 which is higher.	Rs.1000 per MT	
5	Bentonite-Entire State	Rs.400 per MT	Rs.500 per MT	
6	Fuller Earth-Entire State	Rs.125 per MT	Rs.125 per MT	
7	Buff colour (waste) the permits not exceed 20% of permit issued For Fullers Earth	Rs.60 per MT	Rs.70 per MT	
8	Limestone under the title "Shahabad Stone"	Rs.70 per 10 Sqmeters or Rs.70 per MT	Rs.50 per 10 Sqmeters or Rs.50 per MT	
9	Limestone(non-cement) when used for building stone- Entire State	Rs.25 per MT	Rs.60 per MT	
10	Ordinary Building Stone(Entire State as defined under clause(g) of Rule2(1))	Rs.60 per MT	Rs.70 per MT	
11	Limeshell-Entire State	100 per MT	120 per MT	
12	Lime Kankar(non cement) Entire State	50 per MT	80 per MT	
13	Agate, Chalcedony, Flint- Entire State	240 per MT	300 per MT	
14	Ordinary Sand-Entire State	60 Per MT	80 Per MT	
15	Steatite and sand stone used for making household utensils / articles-Entire State.	40 Per MT	80 Per MT	

16	(i)Murrum (All types of soils)- Entire State	20 per MT	40 per MT
	(ii)Clay used for manufacturing tile sand bricks	40 per MT	60 per MT
17	Waste rocks generated in ornamental stone quarry-which is suitable for ornamental purpose Entire State (See explanation under Rule36)	300 per MT or 850 CUM	300perMT
18	Irregular shaped waste rock generated in Ornamental stone quarry, which is not suitable for ornamental purpose (used for making aggregates and m-sand) Entire State.	60 per MT	40 per MT
19	Waste rocks generated in Shahabad stone quarry-Entire State (See explanation under Rule-36)	60 per MT	40 per MT
20	Finished Kerb stones/cubes not exceeding 30 cms each face- Entire State.	110per MT	150 per MT
21	Barytes (i) A Grade (Grey colour (ii) B Grade (Greycolour) (iii) C, D Grade &Waste	6.5% of average selling price or of sale value whichever is higher on ad- valorem basis	400 per MT 300 per MT 200 per MT
22	Calcite	15% of average selling price or of sale value whichever is higher on ad-valorem basis	80 per MT
23	China clay and Kaolin (including Ball clay, White shell, Fireclay and white clay) i)Crude/Raw	8% of average selling price or of sale value whichever is higher on ad-valorem basis.	80 Per MT
	ii)Processed	12% of average selling price or of sale value whichever is higher on ad-valorem basis	600 per MT
24	Corundum	12% of average selling price or of sale value whichever is higher on ad-valorem basis	15% of Sale Value or of Average Selling Price on ad valorem basis which is higher.
25	Dolomite	Rs.75 per MT	100 per MT
26	Dunite and Pyroxenite	Rs. 30 per MT	60 per MT
27	Felsite (Other than for ornamental purpose)	12% of average selling price or of sale value whichever is higher on ad-valorem basis	120 per MT
28	Gypsum	20% of average selling price or of sale value whichever is higher on ad-valorem basis	150 per MT

29	Jasper	12% of average selling price or of sale value whichever is higher on ad-valorem basis	150 per MT
30	Quartz, feldspar	15% of average selling price or of sale value whichever is higher on ad-valorem basis	100 per MT
31	Mica i. Crude ii. Waste	4% of average selling price or of sale value whichever is higher on ad-valorem basis	1500 per MT 500 per MT
32	Quartzite & Fuchsite Quartzite not suitable for use as Ornamental /Gemstones	12% of average selling price or of sale value whichever is higher on ad-valorem basis	100 per MT
33	Laterite i) /dispatched for use in cement or chemical industries or Abrasive or Refractory purpose (below threshold value as specified by IBM from time to time) ii) For use as building stone (below threshold value as specified by IBM)	Rs.60 per MT	160 per MT 60 per MT
34	Ochre	Rs.24 per MT	60 per MT
35	Pyrophyllite	20% of average selling price or of sale value whichever is higher on ad-valorem basis	200 per MT
36	Shale	Rs.60 per MT	150 per MT
37	Slate	Rs.45 per MT	150 per MT
38	Silica Sand	10% of average selling price or of sale value whichever is higher on ad-valorem basis	100 per MT
39	Steatite or Soapstone (Other than for house hold articles)	18%of average selling price or of sale value whichever is higher on ad-valorem basis	200perMT
	Talc	--	200perMT
40	All other minerals (which is not specified in schedule-II) Entire State	30% of sale value on ad-valorem basis	30% of Sale Value or of Average Selling Price on ad-valorem basis which is higher.

As per order of Deputy Director mines and Geological department dated 11-11-2021. The prevailing rates as per the updated order of the Geological Department during the course of the project will be applicable.

Note: Except where otherwise stated, the contractor shall pay to the authority all tonnage and other royalties, rent and other payments or compensation if any, for getting stone, sand, gravel, clay or other materials by him and his subordinates and his subcontractors and required for the works, at the rates and such conditions as notified by the State Government. The contractor should submit the Mineral Dispatch Permit (MDP) in original for the quantity executed by the contractor for the requisite quantity of material incorporated in works for which MDP is issued by the authorized supplier. If contractor fails to submit the MDP in original the amount will be deducted at 5 times the royalty charges from the contractor's bills as per prevailing orders issued by the Authority.

____\$\$****\$\$____

SECTION VII**SCHEDULE – B****MINIMUM RATES OF WAGES****ABSTRACT OF MINIMUM RATES OF WAGES FROM RELEVANT NOTIFICATIONS
MINIMUM RATES OF WAGES APPLICABLE IN THE BEAT OF ALC(C), MANGALORE WITH
EFFECT FROM 01.10.2024**

Minimum Wages applicable “Construction or maintenance of roads, runways or in building operations including laying down underground electric, wireless, radio, television, telephone and overseas communication cables and similar other underground cabling work, electric lines, water supply lines and sewerage pipelines”-

Category			
	Area: A	Area:B	Area:C
Unskilled	783.00	655.00	526.00
Semiskilled/ Unskilled Supervisory	868.00	739.00	614.00
Skilled/Clerical	954.00	868.00	739.00
Highly Skilled	1035.00	954.00	868.00

(Kindly Note: Area A: Bangalore (UA), Area B: Mangalore (UA), Mysore (UA), Belgaum (UA), Hubli-Dharwad, Area C: All other places in Karnataka not specified above as per Ministry of Labour and Employment F.No. 1 /7(3)/2023-LS-II dated 02.04.2024.)

“Employment of Sweeping and Cleaning excluding activities prohibited under the Employment of Manual Scavengers and Construction of Dry latrines (Prohibition) Act, 1933”.

Area	Rates of wages Rs.
‘A’	783.00
‘B’	655.00
‘C’	526.00

“Employment of Watch and Ward”-Rates of wages for employees employed in watch and ward – Govt. of India, Ministry of Labour

Area	Without arms	With arms
	Rates of wages Rs.	Rates of wages Rs.
‘A’	954.00	1035.00
‘B’	868.00	954.00
‘C’	739.00	868.00

For further details log on to Ministry of Employment