



NEW MANGALORE PORT AUTHORITY
Ministry of Ports, Shipping
and waterways, Govt.of India

TENDER DOCUMENT FOR
“Upgradation of Local Area Network at New Mangalore Port Authority
Campus.”

2022

LIST OF DOCUMENTS

1	Special Instructions to the Bidders for the E-Submission of the Bids Online Through E-Procurement Portal	PART - I	
2	Tender Document	PART - II	
3	Price Bid	PART- III	
4	NMPA Bank Details	PART - IV	
5	Checklist	PART - V	

SPECIAL INSTRUCTIONS TO THE BIDDERS FOR THE E-SUBMISSION OF THE BIDS ONLINE THROUGH E-PROCUREMENT PORTAL

N.I.T. No. NMPA/IT/LAN/2022-23/02

Dated: 21/12/2022

TITLE OF WORK: TENDER FOR “Upgradation of Local Area Network at New Mangalore Port Authority Campus”.

1. बोलीदाता को होम पेज में उपलब्ध क्लिक हियर टू एनरोल का उपयोग करके पोर्टल में ऑनलाइन नामांकन करना चाहिए। फिर पोर्टल पर लॉग इन करने के बाद ई-टोकन के साथ डिजिटल सिग्नेचर एनरोलमेंट करना होगा। Bidder should do Online Enrolment in the Portal using the option Click Here to Enroll available in the Home Page. Then the Digital Signature enrollment has to be done with the e-token, after logging into the portal.

2. तत्पश्चात बोलीधारक नामांकन के दौरान चुने गए उपयोगकर्ता आईडी / पासवर्ड पोर्टल में लॉग इन कर पाएंगे। Bidder then logs into the portal giving user id/password chosen during enrollment.

3. दूसरों द्वारा दुरुपयोग न करते हुए पंजीकृत ई-टोकन का उपयोग बोलीदाता द्वारा ही किया जाना चाहिए। The e-token that is registered should be used by the Bidder and should not be misused by others.

4. किसी खाते में मैप किए जाने पर DSC को किसी अन्य खाते में दोबारा नहीं भेजा जा सकता है। यह केवल निष्क्रिय हो सकता है DSC once mapped to an account cannot be remapped to any other account. It can only be inactivated.

5. बोलीदाता अग्रिम रूप से अद्यतन कर सकते हैं, दस्तावेज़ जैसे प्रमाणपत्र, खरीद आदेश विवरण आदि, मेरे दस्तावेज़ विकल्प के तहत और इन्हें निविदा आवश्यकताओं के अनुसार चुना जा सकता है और फिर बोली जमा करने के दौरान बोली दस्तावेजों के साथ संलग्न किया जा सकता है। यह बोली दस्तावेजों के कम अपलोड को सुनिश्चित करेगा। The Bidders can update well in advance, the documents such as certificates, purchase order details etc., Under My Documents option and these can be selected as per tender requirements and then attached along with bid documents during bid submission. This will ensure lesser upload of bid documents.

6. निविदा कार्यक्रम डाउनलोड करने / प्राप्त करने के बाद, बोलीदाता को सावधानीपूर्वक उनके माध्यम से जाना चाहिए और फिर निविदा दस्तावेज के अनुसार दस्तावेज जमा करना चाहिए; अन्यथा, बोली अस्वीकार कर दी जाएगी After downloading / getting the tender schedules, the Bidder should go

through them carefully and then submit the documents as per the tender document; otherwise, the bid will be rejected.

7. बीओक्यू टेम्पलेट को बोलीदाता द्वारा संशोधित / प्रतिस्थापित नहीं किया जाना चाहिए और संबंधित कॉलम भरने के बाद उसे अपलोड किया जाना चाहिए, अन्यथा बोलीदाता उस निविदा के लिए अस्वीकार किए जाने के लिए उत्तरदायी है। बोलीदाताओं को केवल बिडर नाम और वैल्यू दर्ज करने की अनुमति है। The BOQ template must not be modified/replaced by the bidder and the same should be uploaded after filling the relevant columns, else the bidder is liable to be rejected for that tender. Bidders are allowed to enter the Bidder Name and Values only.

8. यदि कोई स्पष्टीकरण हैं, तो यह ई-प्रोक्योरमेंट पोर्टल के माध्यम से या निविदा दस्तावेज में दिए गए संपर्क विवरण के माध्यम से ऑनलाइन प्राप्त किया जा सकता है। बोलीदाता को पोर्टल पर ऑनलाइन या <http://eprocure.gov.in/eprocure/app> or <http://newmangaloreport.gov.in> पर बोली प्रस्तुत करने से पहले प्रकाशित किए गए कोरिगेण्डम को ध्यान में रखना चाहिए, बोलीदाता को अग्रिम में बोली दस्तावेज तैयार करने चाहिए। निविदा अनुसूची में दर्शाए अनुसार प्रस्तुत किया जाना चाहिए और वे पीडीएफ प्रारूपों में होने चाहिए। If there are any clarifications, this may be obtained online through the e-Procurement Portal, or through the contact details given in the tender document. Bidder should take into account the corrigendum published before submitting the bids online on the portal or on <http://eprocure.gov.in/eprocure/app> or <http://newmangaloreport.gov.in> Bidder, in advance, should prepare the bid documents to be submitted as indicated in the tender schedule and they should be in PDF formats.

9. निविदाकर्ता को निविदा में निर्दिष्ट अनुसार बोली सुरक्षा घोषणा और निविदा शुल्क की व्यवस्था करनी होगी। निविदा के लिए निविदा प्रस्तुत करने की तिथि और समय के भीतर मूल को व्यक्ति को निविदा आमंत्रण प्राधिकरण में पोस्ट / कुरियर / दियाकरना होगा। Bidder should arrange for the Bid Security declaration and tender fee as specified in the tender. The original should be posted/couriered/given in person to the Tender Inviting Authority, within the bid submission date and time for the tender.

10. बोली लगाने वाले को नियमों और शर्तों को पढ़ना चाहिए और बोलियों को जमा करने के लिए आगे बढ़ने के लिए उसी को स्वीकार करना चाहिए | The Bidder should read the terms and conditions and accepts the same to proceed further to submit the bids.

11. बोली प्रस्तुत करने की प्रक्रिया के दौरान किसी भी देरी या समस्या से बचने के लिए बोली लगाने वाले को निर्धारित समय से पहले निविदा दस्तावेजों को ऑनलाइन जमा करना चाहिए। The Bidder has to submit the tender document(s) online well in advance before the prescribed time to avoid any delay or problem during the bid submission process.

12. सर्वर के अंत में अपलोड की गई फ़ाइल के आकार की कोई सीमा नहीं है। हालाँकि, अपलोड क्लाइंट सिस्टम पर उपलब्ध मेमोरी के साथ-साथ उस समय क्लाइंट साइड पर उपलब्ध नेटवर्क बैंडविड्थ पर तय किया जाता है। फ़ाइल का आकार कम करने के लिए, बोलीदाताओं को 75-100 DPI में दस्तावेज़ों को स्कैन करने का सुझाव दिया जाता है ताकि स्पष्टता बनी रहे और फ़ाइल का आकार कम हो जाए। यह बहुत कम बैंडविड्थ की गति पर भी त्वरित अपलोड करने में मदद करेगा। There is no limit on the size of the file uploaded at the server end. However, the upload is decided on the Memory available at the Client System as well as the Network bandwidth available at the client side at that point of time. In order to reduce the file size, bidders are suggested to scan the documents in 75-100 DPI so that the clarity is maintained and the size of file gets reduced. This will help in quick uploading even at very low bandwidth speeds.

13. यह ध्यान रखना महत्वपूर्ण है कि, बोली लगाने वाले को फ्रीज बोली बटन पर क्लिक करना होगा, यह सुनिश्चित करने के लिए कि वह बोली प्रस्तुत करने की प्रक्रिया पूरी करता है। बोलियां, जो अवरूद्ध हुए नहीं हैं, को अपूर्ण / अमान्य बोलियों के रूप में मानकर तथा मूल्यांकन उद्देश्यों के लिए नहीं माना जायेगा।

It is important to note that, the bidder has to click on the Freeze Bid Button, to ensure that, he/she completes the Bid Submission Process. Bids, which are not frozen, are considered as Incomplete/Invalid bids and are not considered for evaluation purposes.

14. स्थानीय मुद्दों के कारण बोलीदाताओं द्वारा ऑनलाइन बोली लगाने के दौरान किसी भी प्रकार की देरी या कठिनाइयों का सामना करने के लिए निविदा आमंत्रण प्राधिकरण (TIA) को जिम्मेदार नहीं ठहराया जाएगा। The Tender Inviting Authority (TIA) will not be held responsible for any sort of delay or the difficulties faced during the submission of bids online by the bidders due to local issues.

15. बोलीदाता इस पोर्टल के माध्यम से ही बोली दस्तावेज़ों को ऑनलाइन मोड में जमा कर सकता है। इस प्रणाली के माध्यम से ऑफ़लाइन दस्तावेज़ों को संभाला नहीं जाएगा। तकनीकी बोली की केवल हार्ड कॉपी ईई (एम) III, एनएमपीटी को नियत तारीख से पहले पहुंचनी चाहिए। बोलीदाता यह सुनिश्चित करेगा कि न्यूनतम योग्यता से संबंधित सभी दस्तावेज़ों को तकनीकी बोली के साथ अनिवार्य रूप से अपलोड किया जाएगा, जिसमें असफल होने पर बोली को सरसरी तौर पर अस्वीकार कर दिया जाएगा। इस संबंध में कोई स्पष्टीकरण नहीं मांगा जाएगा The bidder may submit the bid documents online mode only, through this portal. Offline documents will not be handled through this system. The bidder shall ensure that all the documents pertaining to minimum qualification

shall be compulsorily uploaded along with the technical Bid failing which the bid shall be rejected summarily. No clarifications shall be sought in this regard.

16. बोली को फ्रीज़ करने के समय, ई-प्रोक्योरमेंट सिस्टम सभी बोली दस्तावेजों को अपलोड करने के बाद एक सफल बोली अपडेटिंग संदेश देगा और फिर बोली सारांश को बोली नंबर, तिथि और जमा करने के समय के साथ दिखाया जाएगा। अन्य सभी प्रासंगिक विवरणों के साथ बोली लगाएं। बोलीकर्ताओं द्वारा प्रस्तुत दस्तावेजों को बोलीदाता के ई-टोकन का उपयोग करके डिजिटल रूप से हस्ताक्षरित किया जाएगा और फिर प्रस्तुत किया जाएगा। At the time of freezing the bid, the e-Procurement system will give a successful bid updating message after uploading all the bid documents submitted and then a bid summary will be shown with the bid no., date & time of submission of the bid with all other relevant details. The documents submitted by the bidders will be digitally signed using the e-token of the bidder and then submitted.

17. बोली प्रस्तुत करने के बाद, बोली सारांश को प्रिंट करना होगा और बोली प्रस्तुत करने के टोकन के रूप में एक एक्रॉलेजमेंट के रूप में रखना होगा। बोली सारांश निविदा निविदा के लिए बोली प्रस्तुत करने के प्रमाण के रूप में कार्य करेगा और बोली उद्घाटन कार्यक्रम में भाग लेने के लिए प्रवेश बिंदु के रूप में भी कार्य करेगा। After the bid submission, the bid summary has to be printed and kept as an acknowledgement as a token of the submission of the bid. The bid summary will act as a proof of bid submission for a tender floated and will also act as an entry point to participate in the bid opening event.

18. सिस्टम से सफल बोली प्रस्तुत करने का मतलब है, कि बोलीदाता द्वारा अपलोड की गई बोलियां प्राप्त होकर सिस्टम में संग्रहीत कर ली गयी हैं; सिस्टम इसकी शुद्धता के लिए प्रमाणित नहीं करता है। Successful bid submission from the system means, the bids as uploaded by the bidder is received and stored in the system. System does not certify for its correctness.

19. बोली लगाने वाले को यह देखना चाहिए कि प्रस्तुत किए गए बोली दस्तावेज वायरस से मुक्त हैं और यदि निविदा खोलने के दौरान वायरस के कारण दस्तावेज नहीं खुल पा रहे हैं तो बोली अस्वीकार कर दी जाएगी। इसके लिए आर्गेनाइजेशन जिम्मेदार नहीं होगी। The bidder should see that the bid documents submitted should be free from virus and if the documents could not be opened, due to virus, during tender opening, the bid is liable to be rejected. Organization will not be responsible for it.

20. टेंडर पोर्टल के शीर्ष पर सर्वर घड़ी से प्रदर्शित होने वाला समय, ई-प्रोक्योरमेंट पोर्टल में बोली प्रस्तुत करने, बोली खोलने आदि के अनुरोध के सभी कार्यों के लिए मान्य होगा। इस पोर्टल में अनुवर्ती समय भारतीय मानक

समय (IST) के अनुसार है जो GMT + 5: 30 है। बोली लगाने के दौरान बोलीदाताओं को इस समय का पालन करना होगा The time that is displayed from the server clock at the top of the tender Portal, will be valid for all actions of requesting bid submission, bid opening etc., in the e-Procurement portal. The Time followed in this portal is as per Indian Standard Time (IST) which is GMT+5:30. The bidders should adhere to this time during bid submission.

21. बोलीकर्ताओं से अनुरोध किया जाता है कि वे बोली प्रस्तुत करने की अंतिम तिथि और समय (सर्वर सिस्टम क्लॉक के अनुसार) से पहले निविदा प्रक्रिया के लिए ऑनलाइन ई-प्रोक्योरमेंट सिस्टम के माध्यम से निविदाएं प्रस्तुत करें। The bidders are requested to submit the bids through online e-Procurement system to the Tender Inviting Authority (TIA) well before the bid submission end date and time (as per Server System Clock).

22. भाग I- तकनीकी बीआईडी के साथ निविदा फार्म शुल्क और बोली सुरक्षा घोषणा जमा किया जाएगा। फीस, बोली सुरक्षा घोषणा के बिना प्रस्तुत बीआईडी, जैसा कि ऊपर उल्लेख किया गया है, मूल्यांकन के लिए विचार नहीं किया जाएगा और सरसरी तौर पर खारिज कर दिया जाएगा। Tender form Fee and Bid security declaration shall be submitted with the Part I- Technical BID. BID submitted without fees and Bid security declaration, as mentioned above will not be considered for evaluation and shall be rejected summarily.

23. बोली लगाने वाला / निविदाकार / ठेकेदार कर विभागों के साथ लागू रिटर्न समय में दाखिल करेगा और दस्तावेजी प्रमाण के रूप में प्रस्तुत करना होगा। The Bidder/Bidder/Contractor shall file the applicable returns with Tax departments in time and submit the same as documentary proof.

24. पोर्ट को क्रेडिट करने के लिए जीएसटी लागू टैक्स चालान में एक अलग लाइन आइटम के रूप में दिखाया जाएगा। The GST applicable shall be shown as a separate line items in the Tax invoices to avail in put credit to Port.

25. ईएमडी / एलडी / एसडी को जब्त करने की स्थिति में, जीएसटी लागू है; तथा जुर्माना लगाने के दौरान जीएसटी लागू किया जायेगा। In the event of forfeiting the LD/SD, GST is applicable and while imposing penalty, applicable GST shall be collected.

सूचकांक /INDEX

SI. No.	Description	Page No.
1	NOTICE INVITING TENDER.	16
2	INSTRUCTIONS TO BIDDER	18
3	GENERAL TERMS & CONDITIONS OF CONTRACT	42
4	SPECIAL CONDITIONS OF CONTRACT	81
5	SCOPE OF WORK	92
6	LETTER COMPRISING THE TENDER – ANNEXURE 1	125
7	PROFORMA OF IRREVOCABLE BANK GUARANTEE TOWARDS BID BOND – ANNEXURE 2	129
8	PARTICULARS OF BIDDER – ANNEXURE 3	132
9	PRE-QUALIFICATION OF BIDDERS– ANNEXURE 4	134
10	FINANCIAL TURNOVER -ANNEXURE 5	136
11	STATEMENT OF LEGAL CAPACITY – ANNEXURE 6	137
12	BANK INFORMATION FOR E-PAYMENT – ANNEXURE 7	138
13	FORMAT OF POWER OF ATTORNEY – ANNEXURE 8	139
14	POWER OF ATTORNEY FOR LEAD MEMBER OF JOINT VENTURE – ANNEXURE 9	141
15	JOINT BIDDING AGREEMENT - ANNEXURE 10	144
16	PRE CONTRACT INTEGRITY PACT – ANNEXURE 11	151
18	DETAILS OF ONGOING CONTRACTS AT NMPA - ANNEXURE 12	158
19	VERIFICATION OF LOCAL CONTENT – ANNEXURE 13	159
20	UNDERTAKING ON INDEMNIFICATION – ANNEXURE 14	160
21	FORM OF AGREEMENT -ANNEXURE 15	161
22	PERFORMANCE OF BANK GUARANTEE -ANNEXURE 16	165
23	UNDERTAKING ON NON-BLACKLISTING –ANNEXURE 17	168
24	UNDERTAKING CHANGES/MODIFICATIONS - ANNEXURE 18	169
25	DECLARATION ON IPR/PATENT RIGHTS -ANNEXURE 19	170
26	CONFLICT OF INTEREST- ANNEXURE 20	171
27	NON-DISCLOSURE AGREEMENT- ANNEXURE 21	172
28	OEM DECLARATIONS - ANNEXURE 22	179
29	PART -III BOQ	181
30	PART IV- NMPA BANK DETAILS	187
31	CHECK LIST	188

SCHEDULE OF TENDER (SoT)

NOTICE INVITING TENDER

N.I.T. No. NMPA/IT/LAN/2022-23/02

Dated: 22/12/2022

Title of Work: Tender for “Upgradation of Local Area Network at New Mangalore Port Authority Campus”.

1	Tender No. e-Tender id	NMPA/IT/LAN/2022-23/02 2022_NMPT_730707
2	Mode of Tender	E-Procurement System (Online Part I - Techno-Commercial Bid and Part II - Price Bid) through e-procurement portal https://eprocure.gov.in/cppp/
3	Date of NIT available to parties to download	22/12/2022 at 15.30 Hrs
4	Start date for submission of online pre- bid queries	23/12/2022 at 10.00 Hrs
5	Last date for submission of online pre -bid queries	28/12/2022 at 17.00 Hrs
6	Date of Pre-bid meeting	02/1/2023 at 11.00Hrs.
7	Estimated Cost	`8,81,21,517/- (Rupees Eight Crore Eighty One Lakhs Twenty one Thousand Five Hundred and Sixteen only) excluding GST
8	Earnest Money Deposit	`20,79,668/- (Rupees Twenty Lakhs Seventy Nine Thousand and Six Hundred and Sixty Eight only) in the form of Bid Bond.
9	Tender Fees	`1680/- (Rupees One Thousand Six Hundred and Eight only) inclusive of 12% GST- Non-refundable or exemption certificate as per clause No 1.1(k) of ITB
10	Date of Starting of e-Tender for submission Bid on line at http://eprocure.gov.in/eprocure/cpp	09/01/2023 at 10.00 HRS

11	Date of closing of e-Tender for submission of Bid.	24/01/2023 at 15.00 HRS
12	Date & Time of opening of Technical Bid.	25/01/2023 at 16.00 HRS
13	Date & Time of opening of Price Bid	To be communicated separately
14	Completion of Upgradation	12 Months(Twelve Months)
15	Contract period	7 years from the Date of Go-live.
16	Validity of Tender	120 days from the date of opening of tender (Tech. Bid)

Amendments to the tender (if any) will be issued only through web sites, www.newmangaloreport.gov.in and CPP Portal www.eprocure.gov.in/eprocure/app.

1. **GENERAL INFORMATION AND INSTRUCTION FOR THE BIDDERS**

1.1 **General Information**

- a. **Last date and time for submission of the Bids: 15:00 Hrs. on 24/01/2023 at 15.00 Hrs.** The bidder has to submit online bids i.e. Technical Bid and Commercial Bid through e-procurement portal <http://eprocure.gov.in/eprocure/app>.
- b. **Manner of submission of the Bids:** Tenders are to be submitted online through the website stated above. The tender document may be downloaded from website & submission of technical bid / financial bid as per Tender time schedule. No manual bid will be accepted.
- c. **Time and date for opening of Bids:** The Techno commercial Bid will be opened electronically **on 25/01/2023 at 16.00 hrs.** Bidders can witness electronic opening of bid.
- d. **Pre -Bid Enquiry:** Pre-bid queries shall be uploaded **online only** in the e-procurement portal on or before 28/12/2022 17.00Hrs. Queries through hard copy or email shall not be entertained. The response to the queries/clarification received from the Bidders shall be uploaded on NMPA/CPP websites.
- e. **Two-Cover system:** Under two cover bid system through e-tendering, only the Techno commercial Bid would be opened on the time and date mentioned above, date of opening of the commercial bid will be initiated after acceptance of the technical bids. Commercial bids of only those firms will be opened whose technical bids are found compliant/suitable after technical evaluation is done by the NMPA.
- f. **Forwarding of Bids:** NA.
- g. **Modification and Withdrawal of Bids:** A bidder may modify or withdraw his bid after submission provided that the written notice of modification or withdrawal is received by the NMPA prior to deadline prescribed for submission of bids. A withdrawal notice may be sent by e-mail but it should be followed by a signed confirmation copy to be sent by post and such signed confirmation should reach the department not later than the deadline for submission of bids. No bid shall be modified after the deadline for submission of bids. No bid may

be withdrawn in the interval between the deadline for submission of bids and expiration of the period of bid validity specified. Withdrawal of a bid during this period will result in Bidder's forfeiture of bid security.

- h. **Clarification regarding contents of the Bids:** During evaluation and comparison of bids, the NMPA may, at its discretion, ask the bidder for clarification of his bid. The request for clarification will be given in writing and no change in prices or substance of the bid will be sought, offered or permitted. No post-bid clarification on the initiative of the bidder will be entertained.
- i. **Rejection of Bids:** Canvassing by the Bidder in any form, unsolicited letter and post-tender correction may invoke summary rejection. Conditional tenders will be rejected.
- j. **Validity of Bids:** The Bids should remain valid till **120 Days** from the last date of submission of bid.
- k. **Earnest Money Deposit and Tender Fee:**
- While submitting commercial bid, the BIDDER shall deposit an amount **₹20,79,668/- (Rupees Twenty Lakhs Seventy Nine Thousand Six hundred Sixty Eight only)** as **Bid Bond in the form of a Bank Guarantee**, in favour of the Authority by a nationalized Bank/Branch at Mangalore as per the format given in **Annexure -II** of the Tender Document.
 - The Bid Bond shall be valid up to a period of 180 days from the Bid Due Date.
 - No interest shall be payable by the 'AUTHORITY' to the BIDDER on Earnest Money for the period of its currency.

But **Tender fee of ₹1,680/- to be submitted along with the tender.**

Tender fee and EMD is not required to be submitted by those Micro and Small Enterprises (MSE) Bidders who are registered with District Industries Centre (DIC) or Khadi and Village Industries commission or Khadi & Industries Board (KVIB) or Coir Board or National Small Industries Corporation (NSIC) or Directorate of Handicrafts and Handlooms or UDYAM registration certificate or any other body specified by Ministry of MSME.

- i) Even though the Bidders meet the qualifying criteria, they are subject to be disqualified and debarred for a period of three (3) years from participating for tenders at New Mangalore Port Authority, if they have:
 - Made misleading or false representations in the forms, statements and attachments submitted in proof of the qualification requirements; and/or
 - Record of poor performance such as abandoning the works, not properly completing the contract, inordinate delays in completion, litigation history with New Mangalore Port Authority or financial failures etc.
- ii) Even though the bidders who have submitted MSME certificate, meet the qualifying criteria of the Tenderers at Part-II Notice Inviting Tender, they are subject to be disqualified and debarred for a period of three (03) years from participating for tenders at New Mangalore Port Authority and duly informing the MSME authorities if they have:
 - Made misleading or false representations in the forms, statements and attachments submitted in proof of the qualification requirements ; and/or
 - Record of poor performance such as abandoning the works, not properly completing the contract, inordinate delays in completion, litigation history with New Mangalore Port Authority or financial failures etc.

1.2 Instructions for Bidders

- a. Technical bid and Price bid will be submitted concurrently, duly digitally signed in the website portal www.eprocure.gov.in/cppp . The tender document may be downloaded from website & submission of technical bid / financial bid as per Tender time schedule.
- b. Tenders are to be submitted online through the website stated above. All the documents uploaded by the Tender Inviting Authority form an integral part of contract Agency/Contractors

they are required to upload all the tender documents along with other documents, as asked for in the tender, through the above website within stipulated date and time as given in the Tender Notice.

- c. The Agency/Contractor shall carefully go through the documents and prepare the required documents, and upload the scanned documents in Portable Document Format (PDF) to the portal in the designated location of Technical Bid. The bidder needs to fill up the rates, downloaded for the financial Bid in the designated cell and upload the same in designated location of financial bid.
- d. The documents uploaded must be virus scanned and digitally signed using the Digital Signature Certificate (DSC) by the authorized signatory.
- e. For submission of e-tender, bidders are requested to get themselves registered with www.eprocure.gov.in website along with class-II/III Digital Signature Certificate (DSC) issued by authorized issuing authority under IT Act 2003.
- f. For complete details, refer website <http://www.eprocure.gov.in> at CPP portal.
- g. The NMPA may issue amendment/errata to the tender documents before due date of submission of tender. The Agency /Contractors are required to read the tender documents in conjunction with amendments, if any, issued by NMPA. The Agency /Contractor are not supposed to incorporate any amendment /errata in the body of tender documents either in ink or pencil. In case the Agency /Contractor on the body of tender incorporate amendments/errata issued, they shall not be considered and the amendment / errata issued by the NMPA shall only hold good. The amendments/errata issued to these documents if any would be uploaded on web site Tender document can be downloaded from NMPA website <http://www.newmangaloreport.gov.in> & <https://www.eprocure.gov.in/cppp>. The Contractors shall visit these sites from time to time to see these amendments/errata.

- h. The bidders are required to upload the completed documents only after satisfying each and every condition laid down in the tender documents.
- i. NMPA reserves the right to postpone and / or extend the date of receipt of opening of tenders or to withdraw the tender notice, without assigning any reason thereof. In such cases, the bidders shall not be entitled to any form of compensation from NMPA.
- j. Transfer of Tender document purchased by one Bidder to another is not permissible. Similarly, transfer of BID submitted by one Bidder to another is also not permissible. No Alteration in the essence of BID, once submitted shall be permissible. In case the Bidder transfers the BID or modifies/withdraws during the period of validity.
- k. Bids received after the stipulated last date and time for receipt, due to any reasons will not be considered.
- l. New Mangalore Port Trust reserves the right to reject any or all the application without assigning any reasons thereof.

NEW MANGALORE PORT AUTHORITY

FINANCE DEPARTMENT

NOTICE INVITING TENDER

N.I.T No. NMPA/IT/LAN/2022-23/02

Dated: 22/12/2022

Name of the work: - “Upgradation of Local Area Network at New Mangalore Port Authority Campus”.

The FA&CAO, New Mangalore Port Authority invites e-tender in **Two Bid** system Techno-Commercial Bid and Price Bid on behalf of New Mangalore Port Authority (NMPA), from reputed, bonafide, resourceful, experienced and eligible bidders for the work **“Upgradation of Local Area Network at New Mangalore Port Authority Campus”**.

Details of **Pre-qualification criteria** for the Tenderers, Time schedule for participation in this tender are detailed below:

1	Tender No. e-Tender id	NMPA/IT/LAN/2022-23/02 2022_NMPT_730707
2	Mode of Tender	E-Procurement System (Online Part I - Techno-Commercial Bid and Part II - Price Bid) through e-procurement portal https://eprocure.gov.in/cppp/
3	Date of NIT available to parties to download	22/12/2022 at 15.30 hrs
4	Start date for submission of online pre- bid queries	23/12/2022 at 10.00 hrs
5	Last date for submission of online pre –bid queries	28/12/2022 at 17.00 hrs
6	Date of Pre-bid meeting	02/01/2023 at 11.00Hrs.
6	Estimated Cost	₹ 8,81,21,517/- (Rupees Eight Crore Eighty One Lakhs Twenty One Thousand Five Hundred and Sixteen only) excluding GST
7	Earnest Money Deposit	₹ 20,79,668/- (Rupees Twenty Lakhs Seventy Nine Thousand Six Hundred Sixty Eight only) in the form of Bid Bond.

8	Tender Fees	₹ 1680/- (Rupees One Thousand Six Hundred and Eight only) inclusive of 12% GST - Non-refundable or exemption certificate as per clause No 1.1(k) of ITB
9	Date of Starting of e-Tender for submission Bid on line at http://eprocure.gov.in/eprocure/cp	09/01/2023 at 10.00 HRS
10	Date of closing of e-Tender for submission of Bid.	24/01/2023 at 15.00 HRS
11	Date & Time of opening of Technical Bid.	25/01/2023 at 16.00 HRS
12	Date & Time of opening of Price Bid	To be communicated separately
13	Completion of Upgradation	12 Months(Twelve Months)
14	Contract period	7 years from the Date of Go-live.

The Tender Fee shall be paid through RTGS in favour of Financial Adviser & Chief Accounts Officer, New Mangalore Port Authority, Mangalore.

Name of the Bank: State Bank of India, Panambur, Mangalore-10.

Bank A/C No. 10205649448

IFSC Code: SBIN0002249

MICR Code: 575002011

Contact details:

E-mail : **shekhar.ps@nmpt.gov.in/asha.kumari@nmpt.gov.in**

Phone No: 0824-2887221 - Sr. Dy. Director (EDP)

0824-2887737 - Jr. Director (EDP)

For more details the bidders may visit the official website of New Mangalore Port Authority.

Website: <https://newmangaloreport.gov.in>

FA&CAO

Email: facao@nmpt.gov.in

0824-2407353

2. INSTRUCTIONS TO BIDDERS

2.1 SCOPE OF BID:

E- tenders in Two Cover system (Techno-Commercial Bid and Price Bid) are invited by FA&CAO on behalf of New Mangalore Port Authority from the reputed, bonafide, resourceful & experienced Companies for the work of upgradation of local area network.

2.2 During the execution of contract, the contractor has to take care that the day to day functioning of Port is not affected.

2.3 Contractor has to carry out any additional work required to be carried out for successful completion of work. The additional work shall be priced as stipulated in tender document.

2.4 As the work has to be carried out in Custom bound area, Contractor has to fulfil all the security formalities at entry gates, related to the security of the port, necessary co-ordination with the port and CISF authorities will have to be carried out by the contractor.

2.5 During the execution, Port may engage external inspection agency as a third party for inspection of quality of the work. All cost involved in engaging third party shall be borne by the NMPA. The findings of such testings /inspection shall be binding on the contractor for compliance. The payments shall be made to the contractor on the certification of third party inspection agency for key milestone(i) and milestone(ii) of Payment terms, clause 3.42

2.6 Contractor has to coordinate with other department officials of NMPA, CISF and other related departments to avoid disturbance of day to day operation of the Port and smooth execution of the proposed work.

2.7 After completion of work, Contractor has to remove and clean all the debris, waste materials, site office, temporary structures etc. from site, before handing over to NMPA.

2.8 Contractor has to abide all rules and regulations of NMPA and time to time instructions of the employer.

2.9 Contractor has to ensure safety of manpower working during execution by providing personal protective equipment (PPE).

- 2.10 Downloading of Tender Documents:** Tender documents are to be downloaded from NMPA web site www.newmangaloreport.gov.in or e-procurement site by the tenderer. The tenderer is responsible to download all the Addendums/ Amendments / Errata/ Replies to the queries of the tenderer etc., if any, issued by the employer, from the web site before submission of the tender. Any shortfall in submissions of the said Addendums/ Amendments / Errata/ Replies to the queries of the tenderer etc. along with the downloaded documents while submitting the tender will not be considered. Incomplete tender documents observed in technical bid (Envelope No.1) shall be outright rejected.
- 2.11 One Bid per Bidder:** Each bidder shall submit only one bid. A bidder who submits or participates in more than one Bid will cause all the proposals with the Bidder's participation to be disqualified.
- 2.12 Cost of Bidding:** The bidder shall bear all costs associated with the preparation and submission of his Bid, and the Employer will in no case be responsible and liable for those costs.
- 2.13 Site visit:** The Bidder is strongly advised to visit and examine the Site and its surrounding areas and obtain, at his own cost and responsibility, all information and data that may be necessary for preparation of the Bid and, if selected, for entering into and execution of Contract for the Works in accordance with the Conditions of Contract. The Bidder will be solely responsible for any death or personal injury, loss of or damage to property, and any other loss, damage caused or incurred by the Bidder and also any costs, and expenses incurred by the Authority or his personnel, as a result of such inspection and Site visit by the Bidder or his personnel or agents. No claim whatsoever shall be entertained by the Authority at any time for any expense or extension of time in completion of the Works on any ground, including but not limited to inaccurate or inadequate data and details given in the Bid Documents; non-availability of resources and facilities including labour and infrastructure at Site and surrounding areas; adverse weather and working conditions prevailing at Site; or any other

similar difficulties which may be encountered by the Contractor during the course of execution of the Works at Site.

2.14 TENDER SUBMISSION:

2.14.1 **Technical Bid:** The technical bid shall contain all the documents/annexures as detailed in Check List Part V.

2.14.2 **EMD(Bid Bond):** –

The bidder shall submit EMD of `20,79,668/- in the form of Bank Guarantee, may also be submitted in the form of insurance surety bonds, Account pay DD.

- The tender not accompanied with EMD shall be summarily rejected, except in the case as per clause 1.1(K) of the General Information for the bidders.
- The bidder shall be disqualified/terminated and may be debarred for a period of three (3) years from participating for tenders at New Mangalore Port Authority duly informing the authorities if applicable, if
 - i. The bidder withdraws the Bid after Bid opening during the period of Bid Validity
 - ii. The successful Bidder fails within the specified time limit to Sign the Agreement and/or furnish the required Performance security.
 - iii. Fail to commence the work on the specified date as per LOA/Work order.
 - iv. If the bid is varied or modified in a manner not acceptable to the Employer during the validity or extended validity period duly agreed by the Bidder.
 - v. If any information or representation submitted by Bidder is found to be false or incorrect.
 - vi. Any effort by the Bidder to influence the Employer on bid evaluation, bid comparison or contract award decision.
 - vii. The Tenders of those Bidders who have failed to submit the original documents of duly signed Integrity Pact, and EMD, Cost of Tender Document in the prescribed formats in hard copy shall

automatically stand rejected and none of their other ENVELOPES will be opened thereafter.

2.14.3 **Tender Fee:**

The bidder shall submit tender fee of `1680/- (Rupees One Thousand Six Hundred and Eighty Only) inclusive of 12% GST - Non-refundable - NEFT Receipt shall be uploaded along with the Technical Bid. Failure in submission of Tender fee will render the Bidders disqualified, except in the case as per clause 1.1(k)

All the documents should be as per the MQC. Technical Bid should not contain Price Bid. "Disclosure / indication of Price in the Technical Bid shall render the tender disqualified and rejected.

The Tender document duly signed and sealed by the Bidder on each page with Annexures duly filled along with amendments issued by NMPA if any.

- a. Letter Comprising the Tender –**Annexure-I**
- b. Proforma of irrevocable Bank Guarantee Towards Bid Bond **Annexure –II**
- c. Particulars of Bidder as per **Annexure –III.**
- d. Supporting documentary evidence of work orders and also satisfactory completion certificate issued by the client, shall be submitted as per **Annexure–IV.**
- e. Financial Turnover – **Annexure –V**
- f. Statement of Legal Capacity **Annexure –VI**
- g. Tenderer shall furnish Bank information for E-Payment **ANNEXURE –VII**
- h. GST Registration Certificate, ESI & PF Registration Certificate and PAN card to be submitted.
- i. Copies of profit and loss statements, balance sheet and Auditor's report duly signed by Auditor with UDIN, for the last three years.
- j. Power of Attorney for signing the Tender **Annexure –VIII**

- k. Power of Attorney for Lead Member of Joint Venture - **Annexure -IX**
- l. Joint Bidding Agreement - **Annexure -X**
- m. Pre Contract Integrity Pact – **Annexure -XI**
- n. Micro and Small Enterprises (MSE) registered with District Industries Centre (DIC) or Khadi and Village Industries commission or Khadi & Industries Board (KVIB) or Coir Board or National Small Industries Corporation (NSIC) or Directorate of Handicrafts and Handlooms or Udyog Aadhar memorandum or any other body specified by Ministry of MSME shall be exempted of EMD and tender fee on producing self-attested supporting certificates along with Technical Bid.
- o. Details of ongoing contracts at NMPA – **Annexure-XII**
- p. Verification of Local Content – **Annexure -XIII**
- q. Undertaking on Indemnification – **Annexure – XIV**
- r. Form of Agreement- **Annexure-XV**
- s. Performance of Bank Guarantee-**Annexure-XVI**
- t. Undertaking on non-blacklisting-**Annexure-XVII**
- u. Undertaking changes/ modifications-**Annexure-XVIII**
- v. Declaration on IPR/Patent rights-**Annexure-XIX**
- w. Conflict of interest-**Annexure-XX**
- x. Non-Disclosure agreement-**Annexure-XXI**
- y. OEM Declarations - Annexure – **XXII**

2.14.4 **PRICE BID:**

Price bid should be quoted in the BOQ template available in the CPP portal only. The BOQ template must not be modified/replaced by the bidder and the same should be uploaded after filling the relevant columns, else the bidder is liable to be rejected for that tender. Bidders are allowed to enter the Bidder Name and Values only. Any condition

imposed in the price bid shall make the tender liable for out-right rejection. The contract shall be for the whole works as described in the scope of work based on the priced Bill of Quantities submitted through CPP portal by the Bidder. The Bidder shall fill in rates and prices for all items of the works described in the Bill of Quantities through CPP portal. Items for which no rate or price is entered by the Bidder will not be paid by the Port when executed and shall be deemed covered by the other rates and prices in the Bill of Quantities. If any Software/licenses/devices/materials etc required for the commissioning of the Network as per scope of work the bidder shall absorb the same in the price bid. **The bidder shall quote for 1st year Warranty and 1st year AMC only in the price bid.** The warranty charges shall be escalated by 5% on 1st year warrantee for the 2nd and 3rd year warranty cumulatively to arrive at total cost of warranty. Similarly, AMC charges shall be escalated by 5% on 1st year AMC for the 2nd, 3rd and 4th year AMC cumulatively to arrive at the total cost of AMC.

2.15 Clarification of the Bidding Documents:

If there are any clarifications, this may be obtained online through the eProcurement Portal, or through the contact details given in the tender document. Bidder should take into account of the corrigendum published before submitting the bids online on the portal or on <http://eprocure.gov.in/eprocure/app> or www.newmangaloreport.gov.in. It is to be noted that no queries, clarifications will be answered which received after closing date of bid clarifications i.e., 28/12/2022 17.00Hrs.

2.16 Pre-Bid Meeting:

A pre-bid conference will be held through video conferencing or at NMPA office, to answer clarifications, if any, on the tender document. This conference will be held on the date notified in the intimation for invitation to tender. Non-attendance at the pre-bid meeting will not be a cause for disqualification of a bidder. Pre-bid

clarifications, including the text of the questions raised (without identifying the source of enquiry) and the responses given will be transmitted without delay to all purchasers of the tender document and published in NEW MANGALORE PORT AUTHORITY official website only.

2.17 Amendment of Bidding Documents:

Any modification of the tender documents as a result of the pre-bid meeting shall be made exclusively through the issue of corrigendum. Any corrigendum thus issued will be published in the NMPA website, shall be part of the tender documents. Prospective bidders are required to keep watch of the NMPA/CPP portals. Such addenda will be numbered and it shall be submitted by the Tenderers as part of their technical bid.

2.18 Preparation of bids:

All documents relating to the bid shall be in the English language.

2.19 Eligible Bidder:-

The invitation for bids is open only to all eligible Bidders meeting the eligibility criteria as defined in clause No 2.20

2.20 MINIMUM QUALIFICATION CRITERIA OF THE TENDERERS:

2.20.1 Financial Criteria:

The Bidder should have an average Annual financial turnover of `2,64,36,455/- for the last 3 financial years 2018-19 & 2019-20, 2020-21.

In case of joint venture, the Lead Bidder should have an average Annual financial turnover of `2,64,36,455/- for the last 3 financial years 2018-19, 2019-20 & 2020-21.

The Bidder shall upload the copy of annual financial turnover for last 3 years (Auditors report in original certified by CA's having UDIN number including relevant profit & loss A/c and Balance sheet).

Note:

- If the bidder / Lead Bidder under Joint Venture is already having ongoing contracts in NMPA, then his combined work order value of all the ongoing contracts shall be deducted from his Financial Capacity. The Financial Capacity of the bidder shall be assessed from the Average Annual Financial Turnover of the Bidder for the last three years ending March 2021. The Bidder shall be technically qualified, only if his balance Financial Capacity after reduction, is equal to or more than the estimate put to tender.
- {Eg: If the Average Annual Turnover of the bidder is ` 3,00,000/- (Rupees Three lakhs only), then the Financial Capacity of the Bidder is considered to be `10,00,000/- (Rupees Ten lakhs only). If the contractor declares total ongoing works at NMPA of value `4,00,000/- (Rupees Four lakhs only) in Annexure- VII, then the contractor can Bid only for the remaining Financial Capacity i.e `6,00,000/- (Rupees Six lakhs only) }
- Ongoing works at NMPA to be calculated as below:
 - Total Value of Work/Contract – Completed Value of the of the Work/Contract

2.20.2 **Technical criteria**

2.20.2.1 **Work experience:**

Experience of having successfully completed similar works during last 7 years ending last day of month previous to the one in which applications are invited should be either of the following:

At least One similar completed work costing not less than the amount equal to `7,04,97,214/- [Excluding GST].

OR

At least Two similar completed works costing not less than the amount equal to **`4,40,60,759/-** each [Excluding GST].

OR

At least Three similar completed works costing not less than the amount equal to **`3,52,48,607/-** each [Excluding GST].

Similar completed work means **“Supply, Installation, Commissioning of structured Local Area Network / upgradation of structured Local Area Network”**.

2.20.2.2 Specific Experience:

The Bidder should have satisfactorily completed the works involving the following:

Sl.No	Nature of Work	Documents to be submitted
1	Supply, installation, and configuration of Core network Components - L3 Switches, VLAN creation, Network Monitoring System, Network Access Control.	The bidder shall submit self-attested photo copies of LOA/work order/ agreements showing the awarded contract value, Completion/ performance Certificates issued by the Client, indicating the date of Completion and completed Contract Value,. The Bidder shall also enclose detailed BOQ with rates and scope of work supporting the LOA/work order/ agreements/completion certificates/ performance certificates.
2	Laying of 3KM OFC with at least 300 Nodes	The bidder shall submit self-attested photo copies of LOA/work order/ agreements showing the awarded contract value, Completion/ performance Certificates issued by the Client, indicating the date of Completion and completed Contract Value,. The Bidder shall also enclose detailed BOQ with rates and scope of work supporting the LOA/work order/

		agreements/completion certificates/ performance certificates.
--	--	--

2.20.3 **Requirements of JV bidding:**

- In case the bidder is single entity, he should satisfy all the requirements of specific Experience as per clause 2.20.2.2
- Single entities, which could not satisfy the above requirements on their own, may form a JV to enable fair and competitive bidding process. In case of JV, the lead member should satisfy at least one requirement among specific Experience single Order Value of 30% of estimate value and other requirements can be satisfied through their JV partner
- In the event of the bids are being submitted by a JV, the JV should satisfy the following criteria:
 - a. Number of members in a Joint Venture shall not exceed 3 (three);
 - b. subject to the provisions of clause (a) above, the Application should contain the information required for each Member of the Joint Venture;
 - c. Members of the Joint Venture shall nominate one member as the lead member (the “Lead Member”). Lead Member shall meet at least 30% requirement of Technical and Financial Capacity required as per Clause 2.20.1 and 2.20.2. The nomination(s) shall be supported by a Power of Attorney, as per the format at **Annexure -IX**, signed by all the other Members of the Joint Venture;

- d. The Application should include a brief description of the roles and responsibilities of individual members, particularly with reference to financial, technical and defect liability obligations;
- e. An individual Applicant cannot at the same time be member of a Joint Venture applying for pre-qualification. Further, a member of a particular Applicant Joint Venture cannot be member of any other Applicant Joint Venture applying for pre-qualification;
- f. The Lead Member shall itself undertake and perform at least 50 (Fifty) per cent or more of the Project.
- g. members of the Joint Venture shall have entered into a binding Joint Bidding Agreement, substantially in the form specified at **Annexure -X** (the “Jt. Bidding Agreement”), for the purpose of making the Application and submitting a Bid in the event of being pre-qualified. The Jt. Bidding Agreement, to be submitted along with the Application, shall, inter alia:
 - i. convey the commitment(s) of the Lead Member in accordance with this RFP, in case the contract to undertake the Project is awarded to the Joint Venture;
 - ii. clearly outline the proposed roles and responsibilities, if any, of each member;
 - iii. commit the approximate share of work to be undertaken by each member;
 - iv. include a statement to the effect that all members of the Joint Venture shall be liable jointly and severally for all obligations of the Contractor in relation to the Project until the completion of the Project (the “Defects Liability

Period”) is achieved in accordance with the Contract; and

- v. Unless and otherwise provided for under this RFQ and the Bidding Documents, there shall not be any amendment to the Jt. Bidding Agreement.

The bidder shall submit self-attested photo copies of LOA/work order/agreements showing the awarded contract value for “similar works” and satisfactory Completion/performance Certificates issued by the Client, indicating the date of Completion and completed Contract Value,. The Bidder shall also enclose detailed BOQ with rates and scope of work supporting the LOA/work order/agreements/completion certificates/performance certificates submitted in the bid. TDS certificate clearly showing the tax deduction from client for related work orders/agreements shall be produced for verification.

Note:

If the completed /performance certificate uploaded is indicating completed value inclusive of GST as applicable, then the bidder shall submit a certificate as per Annexure 4, indicating the completed value of works excluding GST.

The bidder has to submit the details of payments received for the works executed in **Annexure 4** in full. In case any information in this annexure is found to be false or incorrect, that particular work shall not be considered for evaluation.

Note:

- i. In case of Joint Ventures, Annexure – 4 shall be furnished separately by each member to the JV. The same may be consolidated by the lead bidder.

ii. Lead Bidder shall upload GST Registration Certificate, ESI, PF and PAN Card and contact details of all the JV members along with technical bid.

2.20.4 Legal entity – The Bidder should be a legal entity-A registered company under the company's act with ISO 9001, 27001 certification.

2.20.5 The Bidder should be OEM or Authorized Dealer/ Distributor/ System Integrator of the OEM of the offered product (Bidder to submit Manufacturer Authorization Form). All switches shall be of the same OEM. However, NMS and NAC may be of different OEMs.

2.20.6 The Bidder should be in Local Area Networking business for a period of Minimum 5 years (supporting documents to be enclosed). The supporting documents such as work completion certificate from the clients, authorized dealer ship/ distributor/ System integrator of the OEM.

2.20.7 Even though the bidders meet the above qualifying criteria, they are subject to be disqualified if they have;

- made misleading or false representations in the forms, statements and attachments submitted in proof of the qualification requirements; and/or
- Record of poor performance such as abandoning the works, not properly completing the contract, inordinate delays in, litigation history or financial failures etc.

The bidders who were Blacklisted/Debarred/Banned by any Government or Non-Government organizations are **not eligible** to participate for the subject work Tender. Amendments/further information etc. pertaining to the tender if any shall be uploaded only on the above mentioned website & CPP Portal / NIC NMPA Portal. Prospective Tenderer's are instructed to view these websites from time to time for any such notification.

2.21 Last date For Submission of Tender: The last date of bid submission 24/01/2023 15.00Hours. The bids received after the

last date will not be considered for evaluation. NMPA may at its sole discretion reserves the right to extend the date for receipt of tender.

2.22 Authority in Signing Tender Documents:

- i. In case of a single entity, the tender should be signed by the person holding a valid Power of Attorney executed in his favour in accordance with the constitution of the Company.
- ii. In case of a Joint Venture, the tender should be signed by the Lead Bidder holding 50% and above share as per Joint Venture agreement and a valid Power of Attorney executed in his favour in accordance with the constitution of the Company.
- iii. The Power of Attorney for signing of Tender and the Power of Attorney for the Lead Member of JV, as per Annexure 8 and 9

2.23 Tenderer to Inform himself fully:

- i. The Tenderer is expected to examine carefully the contents of all the documents provided like instructions to the Tenderers, General Conditions, Scope of work etc. Failure to comply with the requirements of the tender will be at the Tenderers own risk. The Tenderer to ensure to make a complete and careful examination of requirements and other information set out in the tender document. The Tenderer shall be deemed to have, visited the site and surroundings and have obtained all necessary information in all the matters whatsoever that might influence while carrying out the Works as per the conditions of the tender and to satisfy himself to sufficiency of his tender etc. prior to quoting their bid.
- ii. The Tenderer is advised to acquaint himself with the job involved at the site, like communication facilities, laws and bye laws in force from Government of Karnataka and Govt. of India and any other Statutory bodies as well as CISF regulation for the issue of passes and collect all information that may be necessary for preparing and submitting the tender and entering into Contract with NMPA.

- iii. Tenderer shall bear all costs associated with the preparation and submission of his tender and NMPA will in no case be responsible sim or liable for these costs, regardless of the conduct or outcome of the tendering process.
- iv. The Tenderer and/or his representatives will be granted permits to visit the site for the purpose of inspection, on receipt of a formal written request. The Tenderer will be fully responsible for any injury (whether fatal or otherwise) to himself or his representatives for any loss or damage to property or for any other loss, damage, costs and expenses whatsoever caused which but for the granting of such permission would not have arisen.

2.24 The successful Bidder fails within the specified time limit to

2.25 Acceptance of Tender: NMPA reserves the right to accept or reject all or any tender without assigning any reasons and does not bind themselves to accept the lowest offer.

2.26 Tender Validity: The Tender shall remain valid for acceptance for a period of **120 days** from the date of opening of Technical Bid. NMPA reserves their right to extend the period of validity for a specific time. The request and the response, there to, shall be made in writing by post, e-Mail. However, in the event of the tenderer agreeing to the request, he shall not be permitted to modify his tender.

2.27 Amendment of Bidding Documents:

- i. Before the deadline for submission of bids, the Employer may modify the bidding documents by using addendum and the same will be uploaded on the CPP /Port websites.
- ii. To give prospective bidders reasonable time in which to take an addendum into account in preparing their bids, the Employer may extend as necessary the deadline for submission of bids.
- iii. To give prospective bidders reasonable time in which to take an addendum into account in preparing their bids, the Employer may extend as necessary the deadline for submission of bids.
- iv. The responsibility of downloading such addendum / amendment from NMPA website and CPP e-portal fully lies with the Bidder.

- 2.28 Language of Tender:** The Tender submitted by the Tenderer and all correspondence and documents relating to the Tender exchanged by the Tenderer and the NMPA shall be written in the **English language**. Any printed literature, other than English language, shall be accompanied by an English translation, in which case, for purpose of interpretation of the tender, the English translation shall govern.
- 2.29 Modification, Substitution & Withdrawal of Proposal:** No offer shall be modified, substituted or withdrawn by the Tenderer after the closing time on due date.
- 2.30 Tender Currencies:** Price shall be quoted in Indian Rupees only and all payments will be made in Indian Rupees.
- 2.31 Contract Price:** The work to be carried out and the Price for the same shall include the work described in the Scope of work & Indicative BoQ, as described in the tender document .The Tenderer shall complete the appropriate price Schedules against Bill of Quantities included herein, stating the deliverables to be supplied under the contract. Prices quoted by the Tenderer shall be firm, fixed and valid till completion of the contract and will not be subject to variation.
- 2.32 Tender deviations.**
Technical bid with counter condition shall be liable for rejection and disqualification.
- 2.33 Non-black listing:**
The Bidder should not have been black listed by any Government Organization. The black listed firms are not eligible to participate for subject work Tender. The bidder submit the document as per Annexure-17
- 2.34 Financial losses and Net worth:**
Bidder firm should not have suffered any financial loss for more than one year during the last three financial year's period ending 31.03.2021.Net worth of the bidder should not be in negative as on 31.03.2021 and should have not eroded by more than 30% in the last three financial year's period ending 31.03.2021.
- 2.35 Tender Opening & Evaluation**

- 2.35.1 The NMPA shall open the Tenders at 16.00 hrs on 25/01/2023 or at the same time on the extended date for submission of the Tenders, in the presence of all Bidders who may be present through their authorized representatives.
- 2.35.2 The Authority will then examine and evaluate Tenders in accordance with the provisions set forth hereunder. The Authority reserves the right not to proceed with the Tendering Process at any time without notice or liability and to reject any and all Tenders without assigning any reason. The Bidders are advised that qualification of Bidders will be entirely at the discretion of the Authority. Bidders will be deemed to have understood and agreed that no explanation or justification on any aspect of the Tendering Process or qualification or selection of Bidders will be given.
- 2.35.3 Prior to the detailed evaluation of bid, the NMPA will determine whether each bid meets the eligibility criteria **defined at 2.20** above, has been properly signed by an authorized signatory holding Power of Attorney in his favor, accompanied by EMD & Tender fee and is responsive to the requirement of the bidding documents. If any of the above conditions are not satisfied, the bid shall be rejected outright.
- i. Conditional offer or alternative offers will not be considered further in the process of tender evaluation.
 - ii. A substantially responsive technical and Financial Bid is one which conforms to all the terms, conditions and specifications of the bidding documents, without material deviation or reservation. A material deviation or reservation is one (a) which affects in any substantial way the scope, quality or performance of the works; (b) which limits in any substantial way, the employers right or bidders obligations under the contract or (c) whose rectification would affect unfairly the competitive position of others bidders presenting responsive bids. The Bidder who does not fulfill the tender requirements

shall not be considered for further evaluation.

The Port Authority reserves the right to reject any tender which in its opinion is non-responsive and no request for alteration, modification, substitution or withdrawal shall be entertained by the Port Authority in respect of such Tenders. The Port Authority would have the right to review the Technical Qualification and seek clarifications wherever necessary.

- iii. After the tender opening, the whole process involving scrutiny, clarifications, evaluation and comparison of tenders and recommendations regarding award of Contract shall be confidential. Any efforts on part of any Bidder to influence the Port Authority in any way in the process of scrutiny, evaluation, comparison of tenders and decision concerning award of Contract may result in rejection of the Bidder's bid.
- iv. To assess the scrutiny, evaluation and comparison of tenders, the Port Authority may ask Bidder individually for clarifications. Clarifications shall be sought only on the documents submitted along with the bid. Request for clarification and response thereto shall be in writing/email. If the Bidder fails to submit the requested documents within the time specified by the department, his bid is liable to be rejected. No change in Price or substance of the tender shall be sought, offered or permitted nor is the Bidder permitted to withdraw the tender before the expiry of the validity period of the tenders in the process of clarifications. The technically qualified/responsive bids shall only be considered for further evaluation.
- v. If a Technical Bid is not substantially responsive, it will be rejected by the employer, and may not subsequently be made responsive by correction or withdrawal of the non-conforming deviation or reservation. The Price/ Financial Bid of those bidders shall not be opened.

2.35.4 **Opening of price bid:**

Tenders, which are found to be in conformity with the Tender requirements, shall be considered for opening of Price Bid.

- i. The Bidders found to be qualified and responsive shall be informed about the date and time of opening of their Price Bids. On the stipulated date and time the Price Bids of such Bidders shall be opened online.
- ii. The evaluation shall be done on the basis of **lowest value (L1)** quoted.
- iii. Further, in order to promote the Make in India Initiative by the Government of India, Class 1 Local suppliers shall get purchase preference over Class II local suppliers as well as Non Local supplier.(Refer GCC Clause 3.1 definitions)
- iv. Among all qualified bids, the lowest bid will be termed as L1, if L1 is Class I Local supplier, the contract will be awarded to L1.
- v. If L1 is not a Class – I Local Supplier, the lowest bidder among the Class –I local supplier, will be invited to match the L1 price subject to Class –I local Supplier's quoted price falling within the margin of Purchase preference, and the contract shall be awarded to such Class – I Local supplier subject to matching the L1 price.
- vi. In case such Lowest eligible Class – I local supplier fails to match the L1 price, the Class–I local supplier with the next higher bid within the margin of purchase preference shall be invited to match the L1 price and so on and contract shall be awarded accordingly. In case none of the Class I supplier within the margin of purchase preference matched the L1 price, the contract may be awarded to the L1 bidder.
- vii. The Bidder whose bid is accepted by the Port Authority, shall be duly informed in writing/email. Within 15 days of receipt of intimation, regarding acceptance of its bid,

the Bidder shall submit draft Contract agreement in the format approved by the Port Authority as in the ANNEXURE 15 of Tender Document, and within a week thereafter the Contract agreement shall be signed between the Port Authority and the successful Bidder.

- viii. If the Bid of the successful Bidder is seriously unbalanced in relation to the Engineer or his Representative's estimate of the cost of work to be performed under the contract, the Employer may require the Bidder to produce detailed price analysis for any or all items of the Bill of Quantities, to demonstrate the internal consistency of those prices with the implementation/construction methods and schedule proposed.
- ix. Offers, deviations & other factors which are in excess of the requirement of the Tender document or otherwise result in the accrual of unsolicited benefits to the Employer shall not be taken into account in Tender evaluation.
- x. The price Bid with any counter conditions will be summarily rejected.

Note : The Class I local supplier/Class II Local Supplier shall submit the self-attested copy of Annexure 13 compulsorily along with the Bid clearly indicating the percentage of local content and provide self-certification that the services/items offered meets the local content requirement for Class I supplier/Class II local supplier, as the case may be.

2.36 Bid Evaluation Criteria (BEC): The Tenderers has to quote the rate for the subject work in the price Bid format excluding GST, ESI & PF. For evaluation of price bids & determination of lowest bidder, the grand total amount shown in the price bid (**exclusive of GST, ESI & PF**) will only be considered.

Comparison and Evaluation of Price Bids will be based on the Grand Total of amount quoted by the Tenderers as per price bid excluding GST, ESI & PF. Applicable GST, ESI & PF shall be paid extra to the Contractor on submitting relevant documents. The Tenderer whose

Price Bid is found to be the lowest to the Port Authority shall be considered for award of Contract.

2.37 Notification of Award and Signing of Agreement:

- i. The bidder whose bid has been accepted will be notified of the award by the employer prior to expiration of the bid validity period. This letter (herein after and in the conditions of contract called the “ letter of acceptance”) will state the sum that the employer will pay the contractor in consideration of the execution completion and maintenance of the works by the contractor as prescribed by the contract (hereinafter and in the contract called the “contract price”). The date of commencement of the contract shall be mentioned in the Letter of Acceptance. The Agreement will also incorporate all correspondence exchanged between the employer and the successful bidder.
- ii. The notification of award will constitute the formation of the contract subject only to the furnishing of a performance security.
- iii. The agreement will incorporate all correspondence between the employer and the successful bidder. The Contractor shall enter into and execute the Contract Agreement, to be prepared and completed at the cost of the Contractor, in the Annexure 15 with such modifications as may be necessary and furnish the performance security within 15 days from the date of signing the agreement. The agreement to be executed on a non-judicial Stamp paper of value `100/-. The contract Agreement shall be signed between the Port Authority and the successful Bidder within 21 Days from the Date of issue of LOA/Work order. The completion period of the contract shall be as mentioned in the LOA/Work order. The Bidder shall submit 5 sets of agreement copies at his own cost.

2.38 Performance Security: The bidder shall submit performance bank guarantee of 3% of the total contract value including GST from any Nationalized/Scheduled Bank in the approved format within 15

days from the date of signing the agreement. The Bank Guarantee shall be kept valid for the total contract period of Seven years plus Six Months claim Period. Thereafter, Performance Security shall be released to the Contractor after successful completion of the Contract, deducting any dues payable to the Port. Failure to comply with the above shall lead to termination of contract. If the contract is extended on mutual consent at the same rates, terms and conditions of the contract, then the Bank Guarantee shall also be extended for the same period plus Six Months claim period. Performance security may also be submitted in the form of insurance surety bond, account payee DD.

2.39 Encashment and appropriation of Performance Security: NMPA shall have the right to invoke and appropriate the proceeds of the Performance Security, in whole or in part, without notice to the bidder for an amount equal to the sum due to NMPA as per this agreement or for recovery of liquidated damages specified in this Contract, provided the Contractor fails to pay such dues on demand by NMPA in 15 days of such demand and no running bills from which recoveries can be effected, is due to be paid to the Contractor. The Contractor's failure to perform its contractual responsibilities, to perform the services, or to meet agreed service levels shall be excused if and to the extent Contractor's non-performance is caused by NMPA's omission to act, delay, wrongful action, failure to provide Inputs, or failure to perform its obligations under this Agreement

Note:- 1.The Penalty for the delay in submission of the Performance guarantee within the stipulate date above shall be at the rate of 0.25% of the amount of performance guarantee for each week or part of the week for the number of weeks delayed beyond the stipulated date of submission.

2.40 Corrupt and Fraudulent Practices: The bidder and their respective officers, employees, agents and advisers shall observe the highest standard of ethics during the Selection Process. Notwithstanding anything to the contrary contained in this document, the Port shall reject the tender without being liable in any manner whatsoever to

the bidder, if it determines that the bidder has, directly or indirectly or through an agent, engaged in corrupt practice, fraudulent practice, coercive practice, undesirable practice or restrictive practice (collectively the “Prohibited Practices”) in the Selection Process. In such an event, the Port shall, without prejudice to its any other rights or remedies, forfeit and appropriate the Bid Security or Performance Security, as the case may be, as mutually agreed genuine pre-estimated compensation and damages payable to the Port for, inter alia, time, cost and effort of the Authority, in regard to the Tender, including consideration and evaluation of such Bidder’s Proposal. Such Bidder shall not be eligible to participate in any tender or RFP issued by the Authority during a period of 3 (three) years from the date such Bidder is found by the Authority to have directly or through an agent, engaged or indulged in any corrupt practice, fraudulent practice, coercive practice, undesirable practice or restrictive practice, as the case may be.

For the purposes of this Clause, the following terms shall have the meaning hereinafter respectively assigned to them:

- a. “corrupt practice” means
 - i) the offering, giving, receiving, or soliciting, directly or indirectly, of anything of value to influence the action of any person connected with the Selection Process (for avoidance of doubt, offering of employment to or employing or engaging in any manner whatsoever, directly or indirectly, any official of the Authority who is or has been associated in any manner, directly or indirectly with the Selection Process or the LOA or has dealt with matters concerning the Agreement or arising there from, before or after the execution thereof, at any time prior to the expiry of one year from the date such official resigns or retires from or otherwise ceases to be in the service of the Authority, shall be deemed to constitute influencing the actions of a person connected with the Selection Process; or
 - ii) engaging in any manner whatsoever, whether during the Selection Process or after the issue of the LOA or after the execution of the Agreement, as the case may be, any person

in respect of any matter relating to the Project or the LOA or the Agreement, who at any time has been or is a legal, financial or technical consultant/ adviser of the Authority in relation to any matter concerning the Project;

- b. “fraudulent practice” means a misrepresentation or omission of facts or disclosure of incomplete facts, in order to influence the Selection Process;
- c. “coercive practice” means impairing or harming or threatening to impair or harm, directly or indirectly, any persons or property to influence any person’s participation or action in the Selection Process;
- d. “undesirable practice” means
 - i) establishing contact with any person connected with or employed or engaged by the Authority with the objective of canvassing, lobbying or in any manner influencing or attempting to influence the Selection Process; or
 - ii) having a Conflict of Interest; and
- e. “restrictive practice” means forming a cartel or arriving at any understanding or arrangement among Applicants with the objective of restricting or manipulating a full and fair competition in the Selection Process.

The bidder shall sign and submit pre-contract integrity pact.

3. GENERAL TERMS AND CONDITIONS OF CONTRACT

A. GENERAL:

3.1 DEFINITIONS:

Terms which are defined in the Contract Data are not also defined in the Conditions of Contract but keep their defined meanings. Capital initials are used to identify defined terms;

- a. **Bill of Quantities** means the priced and completed Bill of Quantities forming part of the Bid.
- b. The **Contract** is the contract between the Employer and the Contractor to execute, complete and maintain the Works.
- c. The **Contract Data** defines the documents and other information which comprise the Contract.
- d. The **Contractor** is a person or corporate body whose Bid to carry out the Works has been accepted by the Employer.
- e. The **Contractor's Bid** is the completed Bidding documents submitted by the Contractor to the Employer.
- f. The **Contract Price** is the price stated in the letter of acceptance and thereafter as adjusted in accordance with the provisions of the Contract.
- g. **Days** are calendar days, **months** are calendar months.
- h. A **Defect** is any part of the Works not completed in accordance with the Contract.

- i. The **Employer** is the party who will employ the Contractor to carry out the Works.
- j. The **Site** is the area defined as such in the Contract Data.
- k. The **Engineer or his nominee** is the person named in the Contract Data (or any other competent person appointed and notified to the contractor to act in replacement of the Engineer or his nominee) who is responsible for supervising the Contractor, administering the Contract, certifying payments due to the Contractor, issuing and valuing Variations to the Contract, awarding extensions of time and valuing the Compensation Events.
- l. The **Start Date** is given in the Contract Data. It is the date when the Contractor shall commence execution of the works. It does not necessarily coincide with any of the Site Possession Date.
- m. A **Variation** is an instruction given by the Engineer or his nominee which varies the Works.
- n. The **Works** are what the Contract requires the Contractor to Supply, maintenance and turn over to the Employer as defined in the Contract Data.
- o. **“Local Content”** means the amount of value added in India which shall unless otherwise prescribed by the Nodal Ministry, be the total value of the item procured (excluding net domestic indirect taxes) minus the value of imported content in the item (including all customs duties) as a proportion of the total value, in percent.
- p. **“Class-I Local supplier”** means a Supplier or Service provider, whose goods, services or works offered for procurement, has local content equal to or more than 50%.
- q. **“Class-II Local Supplier”** means a supplier or service provider, whose goods, services or works offered for procurement, has local content more than 20% but less than 50%.
- r. **“Non-Local supplier”** means a supplier or service provider, whose goods, services or works offered for procurement, has local content less than or equal to 20%.
- s. **“Margin of purchase preference”** means the maximum extent to which the price quoted by a Class – I local supplier may be above

the L1 for the purpose of purchase preference, which shall be 20%.

- t. **“L1”** means the lowest tender or lowest bid or the lowest quotation received in a tender, bidding process or other procurement solicitation as adjudged in the evaluation process as per the tender or other procurement solicitation.
- u. **“Nodal Ministry”** means the Ministry or Department identified pursuant to this order in respect of a particular item of goods or services or works.
- v. **“Procurement entity”** means a Ministry or Department or attached or subordinate office of or autonomous body controlled by the Government of India and includes Government companies as defined in the companies act.
- w. The **Trained Work Person** are those employed / proposed to be employed by the Contractor at the Project Site, who have participated and are in possession of a valid Competency Certificate through a programme run under the auspices of a University, State Technical Board, Ministry of Government of India.

3.2 INTERPRETATION:

- i. In interpreting these Conditions of Contract, singular also means plural, male also means female or neuter and the other way around. Headings have no significance. Words have their normal meaning under the language of the Contract unless specifically defined. The Engineer or his nominee will provide instructions clarifying queries about the Conditions of Contract.
- ii. If sectional completion is specified in the Contract Data, references in the Conditions of Contract to the Works, the Completion Date, and the Intended Completion Date apply to any Section of the Works (other than references to the Completion Date and Intended Completion date for the whole of the Works).
- iii. The documents forming the Contract shall be interpreted in the following order of priority:
 - Agreement

- Letter of Acceptance.
- Contractors Bid
- Contract Data
- Conditions of Contract including Special Conditions of Contract.
- Specifications
- Drawings, if any
- Bill of quantities and
- Any other documents listed in the Contract Data as forming part of the Contract.
- Amendments
- RFP

3.3 Language and Law:

The language of the Contract and the law governing the Contract are stated in the Contract Data.

3.4 Representations and warranties of the Contractor: The Contractor represents and warrants to the Authority that:

- a. it is duly organized and validly existing under the laws of India, and has full power and authority to execute and perform its obligations under this Agreement and to carry out the transactions contemplated hereby;
- b. it has taken all necessary corporate and other actions under Applicable Laws to authorize the execution and delivery of this Agreement and to validly exercise its rights and perform its obligations under this Agreement;
- c. this Agreement constitutes its legal, valid and binding obligation, enforceable against it in accordance with the terms hereof, and its obligations under this Agreement will be legally valid, binding and enforceable obligations against it in accordance with the terms hereof;
- d. it is subject to the laws of India, and hereby expressly and irrevocably waives any immunity in any jurisdiction in respect of this Agreement or matters arising thereunder including any obligation, liability or responsibility hereunder;

- e. the information furnished in the Bid and as updated on or before the date of this Agreement is true and accurate in all respects as on the date of this Agreement;
- f. the execution, delivery and performance of this Agreement will not conflict with, result in the breach of, constitute a default under, or accelerate performance required by any of the terms of its memorandum and articles of association or any Applicable Laws or any covenant, contract, agreement, arrangement, understanding, decree or order to which it is a party or by which it or any of its properties or assets is bound or affected;
- g. there are no actions, suits, proceedings, or investigations pending or, to its knowledge, threatened against it at law or in equity before any court or before any other judicial, quasi-judicial or other authority, the outcome of which may result in the breach of this Agreement or which individually or in the aggregate may result in any material impairment of its ability to perform any of its obligations under this Agreement;
- h. it has no knowledge of any violation or default with respect to any order, writ, injunction or decree of any court or any legally binding order of any Government Instrumentality which may result in any material adverse effect on its ability to perform its obligations under this Agreement and no fact or circumstance exists which may give rise to such proceedings that would adversely affect the performance of its obligations under this Agreement;
- i. it has complied with Applicable Laws in all material respects and has not been subject to any fines, penalties, injunctive relief or any other civil or criminal liabilities which in the aggregate have or may have a material adverse effect on its ability to perform its obligations under this Agreement;
- j. no representation or warranty by it contained herein or in any other document furnished by it to the Authority or to any Government Instrumentality in relation to Applicable Permits contains or will contain any untrue or misleading statement of

material fact or omits or will omit to state a material fact necessary to make such representation or warranty not misleading;

- k. no sums, in cash or kind, have been paid or will be paid, by it or on its behalf, to a person by way of fees, commission or otherwise for securing the contract or entering into this Agreement or for influencing or attempting to influence any officer or employee of the Authority in connection therewith;
- l. all information provided by the {selected bidder/ members of the JV} in response to the Request for Qualification and Request for Proposals or otherwise, is to the best of its knowledge and belief, true and accurate in all material respects;
- m. all undertakings and obligations of the Contractor arising from the Request for Qualification and Request for Proposals or otherwise shall be binding on the Contractor as if they form part of this Agreement; and
- n. Nothing contained in this Agreement shall create any contractual relationship or obligation between the Authority and any Sub contractors, designers, consultants or agents of the Contractor.

3.5 Representations and warranties of the Authority: The Authority represents and warrants to the Contractor that:

- a. it has full power and authority to execute, deliver and perform its obligations under this Agreement and to carry out the transactions contemplated herein and that it has taken all actions necessary to execute this Agreement, exercise its rights and perform its obligations, under this Agreement;
- b. it has taken all necessary actions under Applicable Laws to authorize the execution, delivery and performance of this Agreement;
- c. it has the financial standing and capacity to perform its obligations under this Agreement;
- d. this Agreement constitutes a legal, valid and binding obligation enforceable against it in accordance with the terms hereof;

- e. it has no knowledge of any violation or default with respect to any order, writ, injunction or any decree of any court or any legally binding order of any Government Instrumentality which may result in any material adverse effect on the Authority's ability to perform its obligations under this Agreement;
- f. it has complied with Applicable Laws in all material respects; it has good and valid right to the Site and has the power and authority to grant the Right of Way in respect thereof to the Contractor;

3.6 Disclosure: In the event that any occurrence or circumstance comes to the attention of either Party that renders any of its aforesaid representations or warranties untrue or incorrect, such Party shall immediately notify the other Party of the same. Such notification shall not have the effect of remedying any breach of the representation or warranty that has been found to be untrue or incorrect nor shall it adversely affect or waive any obligation of either Party under this Agreement.

3.7 Extension of time for completion :

3.7.1 Without prejudice to any other provision of this Agreement for and in respect of extension of time, the Contractor shall be entitled to extension of time in the Project Completion Schedule (the "Time Extension") to the extent that completion of any Project Milestone is or will be delayed by any of the following, namely:

- a. site readiness;
- b. Change of Scope,
- c. Occurrence of a Force Majeure Event;
- d. any delay, impediment or prevention caused by or attributable to the Authority, the Authority's personnel or the Authority's other contractors on the Site; and
- e. Any other cause or delay which entitles the Contractor to Time Extension in accordance with the provisions of this Agreement.

The Contractor shall, no later than 15 (fifteen) business days from the occurrence of an event or circumstance specified above, inform the Authority's Engineer by notice in writing, with a copy to the Authority, stating in reasonable detail with supporting particulars, the event or circumstances giving rise to the claim for Time Extension in accordance with the provisions of this Agreement. Provided that the period of 15 (fifteen) business days shall be calculated from the date on which the Contractor became aware, or should have become aware, of the occurrence of such an event or circumstance.

3.7.2 Provided further that notwithstanding anything to the contrary contained in this Agreement, Time Extension shall be due and applicable only for the Works which are affected by the aforesaid events or circumstances and shall not in any manner affect the Project Completion Schedule for and in respect of the Works which are not affected thereby.

3.7.3 In the event of the failure of the Contractor to issue to the Authority's Engineer a notice in accordance with the provisions within the time specified therein, the Contractor shall not be entitled to any Time Extension and shall forfeit its right to any such claims in future. For the avoidance of doubt, in the event of failure of the Contractor to issue notice as specified, the Authority shall be discharged from all liability in connection therewith.

3.7.4 The Authority's Engineer shall, on receipt of a claim in accordance with the provisions, examine the claim expeditiously within the time frame specified herein. In the event the Authority's Engineer requires any clarifications to examine the claim, the Authority's Engineer shall seek the same within 15 (fifteen) days from the date of receiving the claim. The Contractor shall, on the receipt of the communication of the Authority's Engineer requesting for clarification, furnish the same to the Authority's Engineer within 10 (ten) days thereof. The Authority's Engineer shall, within a period of 30 (thirty) days from the date

of receipt of such clarifications, forward in writing to the Contractor its determination of Time Extension. For the avoidance of doubt, the Parties agree that the Authority's Engineer shall, in accordance with the provisions of this Agreement, notify the Contractor of the aforesaid Time Extension no later than 60 (sixty) days from the date of receipt of the Contractor's claim for Time Extension.

3.8 Incomplete Works:

In the event the Contractor fails to complete the Works in accordance with the Project Completion Schedule, including any Time Extension granted under this Agreement, the Contractor shall endeavour to complete the balance work expeditiously and shall pay Damages to the Authority in accordance with the provisions of this tender for delay of each day until the Works are completed in accordance with the provisions of this Agreement. Recovery of Damages, risk and cost under this Clause shall be without prejudice to the rights of the Authority under this Agreement including the right to termination.

3.9 Inspection and technical audit by the Authority:

The Authority or any representative authorized by the Authority in this behalf may inspect and review the progress and quality of the Works and issue appropriate directions to the Authority's Engineer and the Contractor for taking remedial action in the event the Works are not in accordance with the provisions of this Agreement.

3.10 Force majeure:

In the event of the contractor / New Mangalore Port being prevented from fulfilling its obligation in full or in part arising out of this contract, due to any Force Majeure event like acts of God (flood, earthquake etc.) or war, civil commotion, strike, Pandemic, endemic etc, the affected party shall forthwith, but in no case later than 24 hrs from the commencement of such event, intimate the other party as to the commencement of such event and continue to intimate after every 7 days during continuance of such event. The affected party shall, upon cessation of such event, promptly inform the other party and shall

commence its obligation in part or in full arising out of this contract, which was kept suspended due to such events of “Force Majeure”.

3.11 Issue of operational Acceptance Certificate :

The Engineer In-charge shall issue an Operational Acceptance Certificate in the specific format or notify the Contractor in writing of any defect or deficiencies or other reason for the failure of the Operational Acceptance Tests. The Contractor shall remedy any defect and/or deficiencies and/or other reasons for the failure of the Operational Acceptance Test notified by the Project Manager. Once such remedies have been made by the Contractor, the Employer shall retest and issue Operational Acceptance Certificate or shall notify the Contractor of further defects, deficiencies, or other reasons for the failure of the Operational Acceptance Test. The procedure shall be repeated, as necessary, until an Operational Acceptance Certificate is issued.

3.12 Joint & Several Liability and Indemnity:

The parties do hereby undertake to be jointly and severally responsible for all the obligations and liabilities relating to the Project in accordance with the terms & conditions of this Bid document.

The parties hereto also undertake and agree that, notwithstanding division and allotment of the scope of work and responsibilities for the Project between the Parties, each of the Parties shall be jointly and severally liable for the performance or non- performance or any and all defaults in the performance of the scope of work of all the other Parties in addition to its own scope of work and responsibility for the Project and shall be liable for satisfactory execution and completion of the entire Contract despite such division and allotment of scope of work and responsibilities.

The parties hereby agree to jointly and severally indemnify and hold the Authority harmless against any loss, cost and damage which may be incurred or sustained by the Authority as a consequence of any performance, non-performance or any default in the performance of scope of work and responsibilities for the Project by any or all of the Parties hereto.

3.13 Limitation of Liability :

Subject to the responsibilities, liabilities and warranties expressly mentioned in the tender, neither party be liable for any indirect, incidental, consequential, special or punitive loss or damage whatsoever and howsoever arising, including but not limited to loss of profits or revenue, loss of data, even if the party shall have been advised of the possibility thereof and the total aggregate liability of either party under the contract shall not exceed the total charges payable by the employer under the contract, for the work, which gives rise to the liability

3.14 Conflict of Interest:

Bidder shall not have a conflict of interest that may affect the selection process or the Project. Any bidder found to have a Conflict of Interest shall be disqualified. Bidder shall furnish an affirmative statement as to the absence of, actual or potential conflict of interest on the part of the Bidder or any prospective subcontractor due to prior, current, or proposed contracts, engagements, or affiliations with NMPA. Additionally, such disclosure shall address any and all potential elements (time frame for service delivery, resource, financial or other) that would adversely impact the ability of the Bidder to complete the requirements as given in the RFP. Undertaking on Conflict of Interest for making declaration to this effect shall be submitted.

3.15 Engineer or his nominees decision:

Except where otherwise specifically stated, the Engineer or his Nominee will decide contractual matters between the Employer and the Contractor in the role representing the Employer.

3.16 Delegation:

The Engineer or his nominee may delegate any of the duties and responsibilities to other people after notifying the Contractor and may cancel any delegation after notifying the Contractor.

3.17 Communications:

Communications between parties which are referred to in the conditions are effective only when in writing. A notice shall be effective only when it is delivered (in terms of Indian Contract Act 1872).

3.18 Personnel:

The Contractor shall employ the personnel as Onsite Support Resource as referred to in the Contract Data to carry out the functions stated in the Schedule or other personnel approved by the Engineer or his nominee. The Engineer or his nominee will approve any proposed replacement of key personnel only if their qualifications, abilities, and relevant experience are substantially equal to or better than those of the personnel listed in the schedule. If the Engineer or his nominee asks the contractor to remove a person who is a member of the contractor's staff of his work force stating the reasons, the contractor shall ensure that the person leaves the site within seven days and has no further connections with the work in the contract.

3.19 Employers and Contractors Risks:

The Employer carries the risks which this Contract states are Employer's risks and the contractor carries the risks which this Contract states are contractor's risks.

3.20 Employers Risks:

The Employers risks are

- a. in so far as they directly affect the execution of the Works in the country where the Permanent Works are to be executed;
- b. war and hostilities (whether war be declared or not), invasion, act of foreign enemies;
- c. rebellion, revolution, insurrection, or military or usurped power, or civil war;
- d. ionizing radiations, or contamination by radioactivity from any nuclear fuel, or from any nuclear waste, from the combustion of nuclear fuel, radioactive toxic explosive or other hazardous properties of any explosive nuclear assembly or nuclear component thereof;
- e. pressure waves caused by aircraft or other aerial devices travelling at sonic or supersonic speeds; and
- f. riot, commotion or disorder, unless solely restricted to the employees of the Contractor or of his Subcontractors and arising from the conduct of the Works;

- g. Unforeseen Rains (Rains if any; during the period other than the Monsoon period as stated in the Tender), floods, tornadoes, earthquakes and landslides.
- h. loss or damage due to the use or occupation by the Employer of any Section or part of the Permanent Works, except as may be provided for in the Contract;
- i. loss or damage to the extent that it is due to the design of the Works, other than any part of the design provided by the Contractor or for which the Contractor is responsible; and
- j. any operation of the forces of nature (in so far as it occurs on the Site) which an experienced contractor:
 - could not have reasonably foreseen, or
 - could reasonably have foreseen, but against which he could not reasonably have taken at least one of the following measures:
 - prevent loss or damage to physical property from occurring by taking appropriate measures, or
 - Insure against.

3.21 CONTRACTORS RISKS:

All risks of loss of or damage to physical property and of personal injury and death which arise during and in consequence of the performance of the Contract other than the excepted risks are the responsibility of the Contractor.

- a. The Contractor is liable to pay all Statutory Compensation to the Labourers/persons engaged by him for the satisfactory execution of the works. If any claim is made against NMPA on this work, the Port Authority shall have right to deduct the same from the bill amount payable to the contractor after verification of the validity and if admissible as per rules.
- b. The Employer (NMPA) shall not be liable for any accident, damage or compensation payable to any workman or other person in the employment of the Contractor or any Sub-contractor.

3.22 INSURANCE:

The insurance shall be as follows;

- a. All the men/women to be deployed by the Contractor for performing the contract shall be insured against injury/accidents/death by the Contractor at his own cost.
- b. The Contractor shall indemnify New Mangalore Port Authority against all losses and claims, in case of death or injury caused to any Person/Property by him during the execution of the work.
- c. The Contractor shall effect and maintain the following policies at no cost to NMPA, during Contract period with an Indian Insurance Company approved by Insurance Regulatory Development Authority of India (IRDA).
- d. The value of third party legal liability for compensation for loss of human life or partial / total disablement as well as for damage to others equipment/material/property shall be of required statutory limit where applicable or as awarded by Court of Law.

The policy will be on claim made basis with retroactive date from the date of commencement of the contract and shall be valid throughout the tenure of the contract period (including defect liability period) and be also valid during the extended period if any.

The policy will be having claim series clause and extended notification clause with cross liability extension.

- **Employer Liability Insurance:** The Contractor shall indemnify and keep indemnified the Employer i.e., NMPA against all damages or compensation payable at Law in respect of or in consequence of any accident or injury to any workman or other person in the employment of the Contractor or Sub-Contractor against all claims, demands, proceedings, costs, charges and expenses whatsoever in respect thereof or in relation thereto and the Employer shall be at liberty to deduct or adjust from the Contractor's

bills an amount that Employer may be called upon to pay towards claims, demands, proceedings, costs, charges and expenses whatsoever in respect of or in relation to any accident or injury referred to above without any reference to the Contractor.

The Contractor shall be registered under ESI as per the relevant statute and act and shall continue such insurance till completion of the Contract covering all the employees/workers/casual labour/contract labour/outsourced persons under his supervision deputed for the said contract work. The Contractor shall also submit such policy of insurance as and when required by the Employer / Employers representatives.

- **Automobile Liability Insurance** covering use of vehicles / mobile equipments used by Contractor or sub-contractor(s) (whether or not owned by them) in connection with the execution of the contract.
- **Claim Lodgment:** In all cases the Contractor shall lodge the claim with the underwriters and also settle the claims. All claims shall be settled in India. However, the Contractor shall proceed with the repairs and/or replacement of the damaged structures / facilities without waiting for the settlement of the claims. In case seizure of materials by concerned authorities the Contractor shall arrange prompt release against bond, securities or cash as required.
- The Contractor shall submit to the Employer;
 - Evidence that the insurances described above have been effected and
 - Copies of policies for the insurances described in the clauses have been submitted.
 - When each premium is paid, the Contractor shall submit evidence of payment to the Employer.

- The Contractor shall keep informed their insurer of any relevant changes to the execution of the works and ensure that insurance is maintained in accordance with the insurance clause.
- The Contractor will indemnify to the fullest extent permitted by law and keep the Employer, its officers, employees and other related parties hold harmless from all claims for bodily injury and property damage that may arise from the performance of the work.

3.23 Instructions:

The Contractor shall carry out all instructions of the Engineer or his nominee which comply with the applicable laws where the Site is located.

3.24 RESOLUTION OF DISPUTES:

3.24.1 Informal dispute resolution

- a. The parties agree to attempt to resolve all disputes arising under the Agreement, equitably and in good faith. To this end, the Parties agree to provide frank, candid and timely disclosure of all relevant facts, information and documents to facilitate discussions between them/their representatives or senior officers.
- b. Any dispute arising out of or in connection with the Agreement shall in the first instance be dealt with in accordance with the escalation procedure as set out for Project Governance Mechanisms

3.24.2 Mediation:

In case the escalations do not help in resolution of the problem within 2 (two) weeks of escalation, both the Parties should agree on a mediator for communication between the two Parties. The process of the mediation would be as follows:

- i. Aggrieved Party should refer the dispute to the identified mediator in writing, with a copy to the other Party. Such

a reference should contain a description of the nature of the dispute, the quantum in dispute (if any) and the relief or remedy sought suitable;

- ii. The mediator shall use his best endeavors to conclude the mediation within a certain number of days of his appointment;
- iii. If no resolution can be reached through mutual discussion or mediation within 30 days then the matter should be referred to experts for advising on the issue.

3.24.3 **Expert Panel:** In case the mediation does not help in resolution and it requires expertise to understand an issue, a neutral panel of 3 experts, agreeable to both parties should be constituted. The process of the expert advisory would be as follows:

- i. Aggrieved party should write to the other party on the failure of previous alternate dispute resolution processes within the timeframe and requesting for expert advisory. This is to be sent with a copy to the mediator;
- ii. Both parties should thereafter agree on the panel of experts who are well conversant with the issue under dispute;
- iii. The expert panel shall use his best endeavours to provide a neutral position on the issue; and
- iv. If no resolution can be reached through the above means within 30 days then the matter should be referred to Arbitration.

3.24.4 **Arbitration:**

- i. Any dispute or difference whatsoever arising between the Parties to this Agreement out of or relating to the construction, meaning, scope, operation or effect of the Agreement or the validity of the breach thereof, which

cannot be resolved through the application of the provisions of the informal dispute resolution mechanism, through mediation and through the resolution through expert panel, as mentioned above, shall be referred for arbitration in accordance with the provisions set forth herein.

- ii. The arbitration proceedings shall be carried under the Indian Arbitration and Conciliation Act, 1996 and any statutory modification or re-enactment thereof. Such disputes shall be referred to a sole arbitrator as mutually agreed upon between the Parties. If the Parties fail to agree on the arbitrator within 30 (thirty) days from receipt of a request by one Party from the other Party to so agree, sole arbitrator shall be appointed by the Hon'ble High Court of Karnataka or any person or institution designated by the Hon'ble High Court of Karnataka upon the request of a Party.
- iii. Arbitration proceedings shall be held in Mangalore and the language of the arbitration proceedings and that of all documents and communications between the Parties shall be English.
- iv. The decision of the majority of arbitrators shall be final and binding upon both Parties. The expenses of the arbitrators as determined by the arbitrators shall be shared equally by Nodal Agency and the Implementation Agency. However, the expenses incurred by each party in connection with the preparation, presentation shall be borne by each Party itself. All arbitration awards shall be in writing and shall state the reasons for the award.
- v. Pending the submission of and/or decision on a dispute, difference or claim or until the arbitral award is made; the Parties shall continue to perform all of their obligations under the Agreement without prejudice to a final adjustment in accordance with such award.

3.25 Delays ordered by the engineer or his nominee:

The Engineer or his nominee may instruct the Contractor to delay the start or progress of any activity within the Works.

3.26 Management Meetings:

- i. Either the Engineer or his nominee or the Contractor may require the other to attend a management meeting. The business of a management meeting shall be to review the plans for remaining work and to deal with matters raised in accordance with the early warning procedure.
- ii. The Engineer or his nominee shall record the business of management meetings and is to provide copies of his record to those attending the meeting and to the Employer. The responsibility of the parties for actions to be taken is to be decided by the Engineer or his nominee either at the management meeting or after the management meeting and stated in writing to all who attended the meeting.

3.27 Early Warning:

- i. The Contractor is to warn the Engineer or his nominee at the earliest opportunity of specific likely future events or circumstances that may adversely affect the quality of the work, increase the Contract Price or delay the execution of works. The Engineer or his nominee may require the Contractor to provide an estimate of the expected effect of the event or circumstance on the Contract Price and Completion Date. The estimate is to be provided by the Contractor as soon as reasonably possible.
- ii. The Contractor shall cooperate with the Engineer or his nominee in making and considering proposals for how the effect of such an event or circumstance can be avoided or reduced by anyone involved in the work and in carrying out any resulting instruction of the Engineer or his nominee.

3.28 Identify defects:

The Engineer or his nominee shall check the Contractor's work and notify the Contractor of any Defects that are found. The Engineer or his nominee may instruct the Contractor to search for a Defect and

to uncover and test any work that the Engineer or his nominee considers may have a Defect. If, as a result of an examination, inspection, measurement or testing, is found to be defective or otherwise not in accordance with the provisions of this Agreement, the Authority's Engineer may reject such Material, work, design or workmanship by giving notice to the Contractor, with reasons. The Contractor shall then promptly make good the Defect and ensure that the rejected item complies with the requirements of this Agreement

3.29 Bill of Quantities:

The Indicative Bill of Quantities is used to calculate the Contract Price. If any Software/licenses/devices/materials etc required for the commissioning of the Network as per scope of work the bidder shall absorb the same in the price bid. The Contractor is paid for the quantity of the work done at the rate in the Bill of Quantities for each item as per Payment terms. The Bill of Quantities is shown in Part – III.

3.30 Variations and its valuation:

- a. The Engineer shall have the power to order the Contractor in writing to make any variation of the Quantity, quantity or form of the works or any part thereof that may, in his opinion, be necessary and the Contractor upon receipt of such an order shall act as follows;
 - i. Increase or decrease the quantity of any work included in the contract.
 - ii. Omit any work included in the contract.
 - iii. Change the routes, position and dimensions of any part of the work.
 - iv. Execute extra and additional work of any kind necessary for completion of the works.
- b. No price escalation is allowed. The rate(s) quoted against the work shall remain firm during the entire contract period. Any change in Forex/rate shall not be considered for price variation.

- c. The Contractor shall not be entitled to any claim of extra or additional work unless they have been carried out under the written orders of the Engineer.

3.31 Compensation events:

The following mutually agreed Compensation Events unless they are caused by the Contractor would be applicable;

- a. The Employer does not give access to a part of the Site by the Site Possession Date stated in the Contract Data.
- b. The Employer modifies the schedule of other contractors in a way which affects the work of the contractor under the contract.
- c. The Engineer or his nominee gives an instruction for dealing with an unforeseen condition, caused by the Employer, or additional work required for safety or other reasons.
- d. Other contractors, public authorities, utilities or the Employer does not work within the dates and other constraints stated in the Contract that cause delay or extra cost to the Contractor.
- e. Other Compensation Events listed in the Contract Data or mentioned in the contract.

Whenever any compensation event occurs, the Contractor will notify the employer, within 14 days in writing. If a compensation event would prevent the work being completed before the Intended Completion Date, the Intended Completion Date shall be extended. The Engineer or his nominee shall decide whether and by how much the Intended Completion Date shall be extended.

3.32 Execution:

The Contractor shall carry out upgradation of local area network as per the directions of the engineer-in-charge and scope of work specified in the tender.

3.33 Compliance with statutes & regulations:

The Contractor shall fulfill all obligations under various labour laws in force and as amended from time to time regarding deployment of engineers in respect of the services provided under the contract. The Contractor shall comply in all respects, with all statutes and

regulations as may be necessary, including clearance from State/Central Govt. Authorities, Pollution Control Boards, Labour Enforcement and Local Authorities. The Contractor shall, at all times during the continuance of the contract, so far as it may be necessary, comply with all the existing enactments including Central and State Legislation as well as any By-Laws of any Local Authorities regarding labour, particularly the Minimum wages Act, Factories Act, Workmen's Compensation Act, Employees' Provident Fund and Family Pension Fund Act, Employees' State Insurance Act, Contract Labour (Regulation and Abolition) Act, Payment of Wages Act, Maternity Benefit Act, National and Festival Holidays Act, Shop and Establishment Act, The Apprentice Act whatsoever in force if these are applicable and keep the Employer indemnified against any loss or claim arising out of contravention of the provisions of the above said enactments by the Contractor. The price quoted by the Contractor in the Contract shall be deemed to include all expenses in the offer whatsoever the Contractor may be required to incur for the compliance with the provisions of the above said legislation. Any obligations findings or otherwise missed under shall be the responsibility of the Contractor and NMPA will take no responsibility for the same. The Contractor shall make necessary arrangements for the Employer to witness the payment made by the Contractor to his staff and labour.

The Contractor shall be obliged and solely responsible to comply with all statutory security requirements in respect of the manpower engaged by him and NMPA shall not be party to any dispute arising out of such deployment by the Contractor.

3.34 Indemnification:

The Contractor shall agree and undertake (**ANNEXURE-XIV**) to indemnify, keep indemnified, defended and hold harmless the NMPA and its Officers against all losses, penalties, costs and expenses, duties of any kind whatsoever which may arise on account of breach un-authorized act, fraud deed or any other acts of Contractor or any of its personnel. The Contractor shall also agree and undertake to

indemnify and keep indemnifies against any order passed by any executive, quasi-judicial or judicial authority wherein the NMPA is compelled to obey the order which arise due to breach of contract by the Contractor.

The Contractor shall indemnify, protect and defend at its own cost, New Mangalore Port Authority and its agents & employees from & against any/all actions, claims, losses or damages arising out of;

- i. Any violation by the Contractor in course of its execution of the contract of any legal provisions or any right of third parties.
- ii. Contractor's failure to exercise the skill and care required for satisfactory execution of the contract.
- iii. The Contractor shall indemnify NMPA against all claims for compensation by or on behalf of any workman employed by him in connection with the contract, for injury or death by accident under the Workman Compensation Act (Act VIII of 1923) as amended from time to time.
- iv. The Contractor shall be responsible for all commissions and omissions on part of manpower engaged for the purpose. NMPA shall not be responsible in any manner whatsoever, in matters of injury/death/health etc. of the Contractor's employees performing duties under the contract.
- v. The Contractor shall fully indemnify the NMPA and users of the materials supplied, against the action claim or demand, costs and expenses, arising from or incurred by reasons of any infringement or alleged infringement of any letters Patent, Registered Design, Trademark or name, Copyright or any other protected rights in respect of any materials supplied or any arrangements, system or methods of using, fixing or working used by the Contractor

3.35 Deduction:

- i. Deduction of taxes at source shall be made from any bills of the Contractor in accordance with the prevailing rules of Govt. /New Mangalore Port Authority.
- ii. While performing under the contract, the damages caused by the Contractor or his workers to any of the Port Authority property

shall be promptly made good by the Contractor at his own cost. In case the Contractor fails to repair/replace the damages, New Mangalore Port Authority shall have the right to take steps to make good the damages and all the cost on this account shall be recovered from the bills of the Contractor or any money due to the Contractor from this contract or any other contract or any other transaction. In determination of the damage, the opinion of the Engineer-In-charge (EIC) shall be conclusive.

- iii. Any dues arising out of failure on the part of the Contractor to carry out any obligation under the contract shall be deducted from the bills of the Contractor or from any money due to the Contractor from this contract or any other contract.
- iv. The Contractor shall be accountable for all losses occurring during the contract period due to negligence or mal-operation of the systems by his staff. The quantum of loss as determined by Engineer-in-Charge shall be conclusive. Such losses shall be deducted from the bills of the Contractor or from any money due to the Contractor from this contract or any other contract.

3.36 Variation in conditions of contract:

In case of any variation in Instructions to Bidders (ITB), General Conditions of Contract (GCC) and the Special Conditions of Contract – if any shall prevail. But in case of any requirement/condition specified in the Scope of Work, it shall prevail over all other conditions. In case of any variation in the tender document which was downloaded by the bidder from the web site, the former shall prevail. For Agreement purpose, the tender document, which is uploaded by the Department, shall be used. It may please be noted that at any time prior to the dead line for submission of Bids, New Mangalore Port Authority may, for any reason, whether at its own initiative or in response to a clarification requested by any prospective bidder, modify the tender document by amendment/issue of addendum. In such cases, New Mangalore Port Authority may, at its discretion, extend the dead line for submission of bid. The Bidders who wish to download the tender document from the web site are

strongly advised to visit the site for such amendments/addendum and note that New Mangalore Port Authority shall not be responsible to intimate them about such amendment/addendum.

3.37 Variation in price offer:

In case of variation between the amount quoted in words & figures, the amount quoted in words shall prevail and in case of variation between rate and amount, the quoted rate shall prevail.

3.38 Personal protective equipment:

The Contractor shall be responsible for taking precautionary measures for the safety of the workmen working under him and the responsibility arising due to any mishap during the execution of work, payment of any compensation etc., lies entirely on the part of the Contractor. Safety Items/Jackets etc., required while working are to be provided by the Contractor.

The Contractor shall be solely responsible, at his own cost, for the supply of required PPE to his employees and he shall also ensure the use of PPE or any other equipment as required depending on nature of work by his staff at site.

3.39 Conduct:

The Contractor, at all times during the tenure of contract, shall take all measures to prevent any unlawful, riotous or disorderly conduct by or amongst his staff at the site and for the preservation of peace and protection of persons and property at the work site as well as in the neighborhood of the works. The Contractor shall have adequate measures in place to ensure that the employed staff at all times complies with the provisions and obligations contained in the tender and as amended from time to time.

3.40 Accident:

- i. The Contractor shall, within 24 hours of the occurrence of any accident, at or about the work site or in connection with execution of the contract, report such accidents to the Engineer-in-Charge giving all the details. He shall also provide additional information about the accident as requested by the EIC.

- ii. The Employer shall not be liable for any accident, damages or compensation payable to any workman or other person in the employment of the Contractor during the contract period.

3.41 Undertaking by the contractor in the price bid:

Having understood all the terms and conditions of the tender document, we hereby confirm that the price offered by us is a firm price and excluding applicable GST.

3.42 Payment terms:

Payment will be made according to the following schedule and procedures:

The Contractor’s request for payment shall be made to the Employer in writing, accompanied by an invoice for the goods or services actually delivered, installed or operationally accepted. No payment made by the Employer herein shall be deemed to constitute acceptance by the Employer of the System or any Subsystem(s).

All statutory levies such as Work contract Tax, GST and all other amounts due to the Employer will be deducted from the amount due to the Contractor and the balance will be paid. Payment will be made through RTGS as far as possible and contractor will be required to provide information on Bank details.

Details of key milestones, activities to be completed, stage payments and the documents that will be required for processing the payment for different types of works under this contract are given below:

Key milestone	Activities to be completed	Payment	Documents
(i) Delivery of Hardware/Software/ Materials as per BoQ.	Receipt of Hardware/ Software/materials in good condition and third party inspection certificate	50%	Third party certificate, manuals, &OEM documents

(ii) Installation, testing and commissioning	Receipt of third party inspection certificate on Installation, testing and commissioning and acceptance by the Port	40%	Third party certificate, Installation certificate & Acceptance report by the Project Manager in Charge
(iii) Completion of Defect Liability Period	Successful Completion of Defect Liability Period	10%	Certificate by Project in Charge.
(iv) Completion of warranty /DLP	Successful Completion of warranty /DLP	100%	Certificate by Project in Charge.
v) Post Warranty Support for the Hardware	At the end of the Quarter.	Pro rata for every quarter, will be made in subsequent quarter	Performance certificate by Project Manager
Man Power Services (From the date of Commissioning)	At the end of the Quarter	Pro rata for every quarter, will be made in subsequent quarter	Performance certificate by Project Manager

Table 1. Payment Schedule

- i) **Provident Fund & ESI:** The Contractor has to remit the PF & ESI contribution regularly to the concerned department for the engineers deployed on site by him. The EPF and ESI contribution

on the part of the employer in respect of this contract shall be paid by the Contractor.

In case the Notice for noncompliance is received from the appropriate agencies (i.e. PF & ESI), the amount due will be deducted from the Contractor's bills and other monies available with the Port.

- ii) The deployed personnel have to attend the duty. In case any personnel is on leave or absent from duty, suitable substitute should be provided by the Contractor, failing which deductions will be made from Contractor's bill as applicable.

3.43 No interest on account of delayed payments:

Any claim for interest will not be entertained by the NMPA with respect to any payment or balance which may be in their hands owing to any disputes between themselves and the Contractor or with respect to any delay on the part of the NMPA in making payment. Further no interest will be paid on Retention money of Performance Security amount.

3.44 Income Tax:

Applicable Income tax will be deducted from the monthly bills and necessary certificate will be issued to the Contractor by the Finance department. All the applicable statutory recoveries shall be made from the monthly bills.

- i. The Contractor shall pay the applicable GST to the concerned department and the documentary evidence of the same to be produced to NMPA for reimbursement by the Port. The Contractor/tenderer shall file the applicable returns with tax Departments on time and submit the same as documentary proof/evidence, GST as applicable shall be shown as a separate line items in the Tax Invoice. If any ITC lost due to non-filing of GST return same will be recovered from Contractor.
- ii. The Contractor shall have the Registration with EPFO & ESIC. The EPF & ESI contribution on the part of the Employer in respect of this contract shall be paid by the Contractor. These

contributions on the part of the Employer paid by the Contractor shall be reimbursed to the Contractor on actual basis.

- iii. The Contractor shall submit month wise Electronic challan cum Returns (ECR) & submit its reference number (TRR NO.) along with the bills for payment.

3.45 Record of attendance:

The Contractor will arrange for Biometric RFID cards for engineers. These RFID card details will be recorded for the purpose of attendance in the Port IT system and intimated to the Contractor. The Contractor will submit the extracts of the attendance sheets along with the wage bill. No Supervisor or Port official will maintain records of attendance of engineers provided by the Contractors.

3.46 Acts of omission or commission:

The Contractor shall be liable for all acts of omission or commission of the personnel deployed and also for all liabilities pertaining to their salaries, Insurance coverage, statutory default or any action due to non-fulfillment of the statutory obligations towards E.P.F., E.S.I., etc. The Contractor shall maintain all the Records/Registers as required under Central and State Contract Labour (Regulation & Abolition) Act. The Contractor shall allow inspection of the wage records etc., to the EIC or his representative.

3.47 Paying authority:

The Contractor should submit the following to the Paying Authority. The payment of bills will be made on the submission of the following documents by the Contractor;

- i. Register of Payment of wages.
- ii. Register of Attendance.
- iii. Claim for statutory and other levies to be supported with requisite documents/proof of payment for EPF/ESIC
- iv. Bank Guarantee for advance, if any.
- v. Proof of Payment of wages (Copy of the bank statement of Contractor).
- vi. Any other document/certificate that may be provided for in the contract.

3.48 Payment of wages:

Payment of wages to the persons engaged by the Contractor shall not be less than the minimum wages applicable. Whenever revision of minimum wages, revised by the Government as per Minimum Wages Act, 1948 during the currency of the contract, the wages paid shall not be less than the revised rates applicable. If the workers are engaged at the discretion of the Contractor, for more than one shift, they shall be paid overtime as applicable at contractor expense and on National & Festival holidays specified by the Port, they will be paid overtime allowance at double the proportionate hourly wages (Double OT shall be Wages for paid holiday and Single Overtime allowance) for the duty performed on such days, as per applicable rules.

- a. The wages paid shall include wages for weekly day of rest. One day in a week will be counted as a mandatory rest day (weekly off).
- b. The wages shall be paid on or before 7th day of every month through the Bank only. Documentary evidence like bank statement of the contractor shall be furnished along with the bills.
- c. Wages, OT etc paid shall be entered in personnel register

3.49 Welfare measures - EPF, ESI etc:

- a. All the workmen of this contract shall be covered with EPF as per the provisions of “The Employees Provident Funds & Miscellaneous Provision Act, 1952”.
- b. All the workmen of this contract shall be compulsory covered as per the provisions of “Employees State Insurance Act, 1948”.
- c. The EPF & ESI contribution of the employees and immediate employer’s contribution shall be remitted to the authorities concerned periodically at the applicable rates by the contractor. However, the immediate employer’s contribution towards ESI &PF shall be reimbursed to the Contractor based on the documentary evidences towards remittance made to such authorities.
- d. The documents related to the payment of EPF, ESI shall be enclosed to the Monthly bills. Further, these documents shall be produced to the enforcement authorities of Central/State Govt, whenever demanded by such authorities. Failure to comply with

EPF, ESI & other applicable welfare measures, the Contractor is liable to pay fines as decided by the enforcement authorities or competent authorities of NMPA. The Contractor shall be accountable for all losses occurring during the contract period due to negligence or faulty maintenance of the systems by his staff. The Employer (NMPA) shall not be liable for any accident, damages or compensation payable to any workman or other person in the employment of the Contractor or any Subcontractor.

3.50 Termination of the contract:

- a. In the event of repeated instances of unsatisfactory service or any failure at any time on the part of the contractor to comply with the terms and provisions of this contract to the satisfaction of NMPA (who shall be the sole judge and whose decision shall be final, it shall also be open to NMPA to terminate this contract by giving not less than Ninety (90) days notice in writing to that effect and if the contractor, does not make good his default within the notice period, NMPA shall be entitled to terminate the contract as a whole or in part duly informing MSME if applicable. In the event of such termination of the contract, NMPA shall be entitled to:
 - i. forfeit the Performance Guarantee as it may consider fit;
 - ii. get the balance/remaining work done by making alternative arrangements as deemed necessary and until such time NMPA is able to appoint a new regular Contractor; and recover from the contractor (appointed under this tender) any extra expenditure incurred by NMPA in getting the work done and damages which NMPA may sustain as a consequence of such action.
- b. If the extra expenditure incurred by NMPA on account of unsatisfactory performance of the contractor as mentioned in paragraphs above is more than the Performance Security proposed to be forfeited, the expenditure over and in excess of the Performance Security may be recovered by deducting the said amount from pending bills of the contractor under this tender or from money due to the contractor by NMPA under this or any other contract or otherwise. The contractor shall have no claim

whatsoever against NMPA, in consequence on such recoveries or termination of the contract, as stated above.

- c. if at any time the contractor becomes insolvent or files an application for insolvency or any creditor of his moves the court for adjudicating him as an insolvent or, if he is convicted by any court of law, withdraws from the contract, NMPA will have the absolute option of terminating the contract forthwith and he shall have no right for damages or compensations on this account.
- d. Further, NMPA may terminate/pre-close the contract at its convenience, if found necessary, by giving a notice period of Ninety days (90) days. The contractor shall not have right of any claim on NMPA on account of such termination.

3.51 Debarring of business dealings:

- 3.51.1 In the event of premature termination of contract in terms of provisions of clause 3.57 NMPA shall also be entitled to **debar** the contractor for participation in future tenders of NMPA for a period of three (03) years duly intimating MSME if applicable.
- 3.51.2 Further, in case if it comes to the notice of NMPA that the bidder/contractor has used forged documents or misrepresented the facts in any manner either to get the contract or during the pendency of the contract, in all such cases NMPA at its sole discretion may terminate the contract and debar such contractor for a period of three (3) years duly intimating MSME if applicable.

3.52 Police verification

- 3.52.1 At all times, the Contractor will be responsible to ensure that the character and antecedents of manpower engaged by him are verified by Police Station of worker's residential area. Police verification is to be submitted prior to the commencement of the contract. The Contractor will also ensure that no person employed by him for the services has been / is involved in any activity against the interest of the

state. A certificate shall be submitted by the Bidder showing that the staff deployed has been verified by the local police for irregularities if any.

3.53 The Bidder shall ensure that,

- a. The workforce deployed under this contract will be provided and use all the necessary safety gears and equipment for the job.
- b. Bidder/deployed staffs will follow all the required safety procedures while executing the job.
- c. They indemnify the port for any accidents/incidents while carrying out the contract.

3.54 Risk clause:

Notwithstanding the other terms therein, the Port at its option will be entitled to terminate the contract and to avail service from elsewhere at the risk and cost of Contractor either the whole of the contract or any part which the Contractor has failed to perform in the opinion of the Port within the time stipulated or if the same performance is not available, the best and the nearest available substitute thereof. The Contractor shall be liable for any loss which the Port may sustain by reason of such risk in addition to penalty.

3.55 Insolvency & Breach of Contract:

The Port may, at any time, by notice in writing summarily terminate the contract without compensation to the Contractor in any of the following events;

- i. If the Contractor being an individual or a firm if any partner in the Contractor's firm shall be adjudged insolvent or shall have a receiving order or order for administration of his estate made against him or shall take any proceedings for liquidation or composition under any insolvency act for the time being in force or make any conveyance or assignment of his effects or enter into and arrangement or composition with his creditors or suspend payment, or if the firm be dissolved under the Partnership Act, or
- ii. If the Contractor being a company shall pass a resolution or the court shall make an order for the liquidation of its affairs or a

- receiver or manager on behalf of the debenture holders shall be appointed or circumstance shall have arisen which entitle the court or debenture holders to appoint a receiver or manager, or
- iii. If the Contractor commits any breach of contract not herein specifically provided always that such determination shall not prejudice any right of action or remedy which shall have then accrued or shall accrue thereafter to the Port provided also that the Contractor shall be liable to pay the Port for any extra expenditure he is thereby put to but shall not be entitled to any gain on re-tender.
 - iv. In the event of inadequate or unsatisfactory performance of duties by the Contractor, the Port shall have the right to bring to the notice of the Contractor the default (s) on their part and the Contractor shall ensure that the said default (s) is / are not repeated and/or are duly remedied, within a period of three days from the receipt of the said notice. Failing such remedial action, or in the event of the said default (s)'s being inadequately corrected, the Port shall have the right to immediately terminate the agreement.

Notwithstanding any other clause herein, if there is any act or omission by the Contractor or the Contract employees which jeopardizes the safety / security of the Port including but not limited to;

- i. Theft or pilferage of property of NMP
- ii. Fire, flooding, breakage or damage
- iii. Violence or physical attack on the Campus
- iv. Any act or incident which may prove detrimental to the interests of NMP -the contract would be terminated without any notice. Further, the Contractor would be levied penalties, as appropriate by the deemed authority. The decision of the NMP Authorities shall be final in such matters.
- v. The Contractor shall pay any claim made by the Port for any deficiency (both tangible and intangible) in service. Such amount may also be deducted from bills payable to the Contractor. It may be noted that the Port shall have the right to forfeit the Security

Deposit in full or part for any due/damages caused by the Contractor. If the Security Deposit or outstanding bills of the Contractor is found inadequate, then such monetary recoveries shall be effected from any amount payable to the Contractor against this or any other contract until the dues of the Port are fully settled. If the claim of the Port could not be met in this manner, the Contractor shall pay up all such claims if a demand is made by NMPA.

3.56 Penalty:

The deployed personnel have to attend the duty. In case any personnel is on leave or absent from duty, suitable substitute should be provided by the Contractor, failing which deductions will be made from Contractor's bill as applicable.

Failure to deploy a manpower resource, a penalty shall be twice the one day wage of that particular resource for number of days, shall be deducted from the monthly bills. Further penalty towards SLA is detailed @ clause No. 5.5

3.57 Termination:

The employer may terminate the contract if Contractor causes a fundamental breach of the contract. Fundamental breaches of contract include, but shall not be limited to the following;

- a. The Contractor stops work for 28 days and the stoppage has not been authorized by the Engineer-in-Charge.
- b. The Engineer-in-Charge instructs the Contractor to delay the progress of the work and the instruction is not withdrawn within 28 days
- c. The Contractor becomes bankrupt
- d. The Engineer-in-Charge gives Notice to the Contractor and the failure to correct a particular defect is a fundamental breach of contract and the Contractor fails to correct it within a reasonable period of time determined by the Engineer-in-Charge.
- e. The Contractor does not maintain a security which is required.

- f. If the Contractor, in the judgment of the employer has engaged in corrupt or fraudulent practices in competing for or in the executing the contract.

For the purpose of this paragraph: “corrupt practice” means the offering, giving receiving or soliciting of anything of value to influence the action or public officials in the procurement process or in contract execution. “Fraudulent practice” means a misrepresentation of facts in order to influence a procurement process or the execution of a contract to the detriment of the employer, and includes collusive practice. Bidders (prior to or after bid submission) designed to establish bid prices at artificial non-competitive levels and to deprive the employer of the benefits of free and open competition”.

If the contract is terminated the Contractor shall stop work immediately, make the site safe and secure and leave the site as soon as reasonably possible.

3.58 Termination for default:

- i. The Board may, without any prejudice to any other remedy for breach of contract, by written notice of default sent to the Contractor, terminate the contract in whole or in part;
 - a. If the Contractor fails to execute the work within the period as specified in the contract or any extension granted by the Board.
 - b. If the Contractor fails to perform any other obligation under the contract and does not cure after receipt of a notice of default, its failure within the time specified in the notice. The notice of default shall specify the nature of default as well as the time within which the default has to be cured by the Contractor.
 - c. If at any point of time it is found that the documents submitted by the bidder is false, appropriate action will be taken to forfeit the SD and BG along with banning the business for the period of Three (03) Years.

- d. In the event of Board's termination of the contract in whole or in part, the Board may execute the remaining work through any other Contractor and the Contractor whose contract is terminated shall remain liable to the Board for any excess cost for such works or goods and risks, if any.
- e. In case of termination of contract for default by the Contractor, the Board may not permit the Contractor to participate in any of the future tender of New Mangalore Port Authority.
- f. The contract may be terminated by NMPA by giving written notice to the Contractor, at least 90 days in advance and Contractor shall not have right of any claim on NMPA on account of such termination.

3.58 Tests:

If the Engineer or his nominee instructs the Contractor to carry out a test not specified in the Specification to check whether any work has a Defect and the test shows that it does the Contractor shall pay for the test and any samples.

3.59 Variations :

The Engineer in Charge shall make any variation of the form, quality or quantity of the Works/Service or any part thereof that may, in his opinion, be necessary and for that purpose, or if for any other reason it shall, in his opinion, be appropriate, he shall have the authority to instruct the Contractor to do and the Contractor shall do any of the following:

- Increase or decrease the quantity of any work/service included in the Contract, Omit any such work/service (partially or fully), Change the character or quality or kind of any such work/service, Execute additional Work/service of any kind necessary for the completion of the Works/ services/ upgradations.

No such variation shall in any way vitiate or invalidate the Contract, by the effect, if any, of all such variations shall be valued, provided that where the issue of an instruction to vary the Works is necessitated by some default of or breach of Contract by the

Contractor or for which he is responsible, any additional cost attributable to such default shall be borne by the Contractor.

3.60 Valuation of Variations:

All variations referred above and any additions to the Contract Price, which are required to be determined, shall be valued as follows:

3.60.1 At the rates and prices set out in the Contract if, in the opinion of the Engineer in Charge, the same shall be applicable.

3.60.2 If the Contract does not contain any rates or prices applicable to the varied Work, the rates and prices in the Contract shall be used as the basis for valuation so far as may be reasonable, failing which after due consultation by the Employer with the Contractor, suitable rates or prices shall be agreed upon between the Employer and the Contractor.

3.60.3 In the event of disagreement the Employer shall fix such rates or prices as are, in his opinion, appropriate and shall notify the Contractor accordingly.

3.61 Mile stone for Completion :

The time period for the upgradation of local area network as per the scope of work shall be **12(Twelve)** months from the date of acceptance of the work order.

After completion of the work, the contractor will serve a written notice to the Engineer or his nominee/Employer to this effect. The Engineer or his nominee/Employer upon receipt of this notice shall conduct a complete joint survey of the work within 7 days and prepare a defects list jointly. The defects in the hardware/software or the solution pointed out by the Engineer or his nominee/ Employer would be rectified by the contractor within 14 days and thereafter acceptance report be signed jointly by the contractor and the Employer. This joint acceptance report shall be treated as 'Completion Certificate

3.62 Liquidated Damages:

a. If the Contractor fails to render the service within the permitted resolution time or any extension of the time for resolving the

issues/delivery of the service, or fails to perform the service, then liquidated damages at 0.5% per week or part thereof of the item as per the contract, will be applicable subject to a limit of 10% of the contract value of the item/work, beyond which the employer will engage a third party to get the issue resolved or service rendered. The expenditure of the employer in this regard will be met from the contractor's next bill, failing which the claim will be settled from the BG.

- b. Such damages will be deducted from any money due to the contractor. The payment of such damages shall not relieve the contractor of his obligations to complete the works/services or from any other of his obligations or liabilities under this contract. This shall not limit, however, any other rights or remedies the Employer may have under the Contract.
- c. In the event that the contractor is delayed or prevented from performing its obligations under this contract due to failure, delay or negligence on the part of the employer, the contractor shall be excused and shall have no liability or obligation and is entitled to an extension of time to perform its obligations. Unless otherwise agreed, the period of the extension will be equal to the amount of time for which the contractor is delayed or prevented from performing its obligations due to such failure, delay or negligence on the part of the employer.

3.63 Severability

If for any reason whatsoever, any provision of this Agreement is or becomes invalid, illegal or unenforceable or is declared by any court of competent jurisdiction or any other instrumentality to be invalid, illegal or unenforceable, the validity, legality or enforceability of the remaining provisions shall not be affected in any manner, and the Parties will negotiate in good faith with a view to agreeing to one or more provisions which may be substituted for such invalid, unenforceable or illegal provisions, as nearly as is practicable to such invalid, illegal or unenforceable provision. Failure to agree upon any

such provisions shall not be subject to the Dispute Resolution Procedure set forth under this Agreement or otherwise.

3.65 Successors and assigns

This Agreement shall be binding upon, and inure to the benefit of the Parties and their respective successors and permitted assigns.

4. SPECIAL CONDITIONS OF CONTRACT

4.1 The rates quoted shall be Firm and inclusive of all cost & Duties and exclusive of applicable GST. The Employer shall not provide any concessional “C” or “D” Form.

4.2 The Tenderer should submit **valid GST, ESI, PF Registration certificates and PAN card** along with the tender. The Tenders without the same shall be liable for rejection and disqualification.

4.3 Contractor’s Working Area/Accommodation:

No accommodation will be provided by the Port. Accommodation will be provided to the staff during contract period based on the availability, on payment as per NMPA rules. The Contractor, shall except when authorized by the Engineer, confine his men, materials and plant in the site of which he is given possession. The Contractor shall not use any part of the site for Purpose not connected with works unless the prior written consent of the EIC.

The office space will be provided to keep all the spare parts, computers, laptops and other accessories related to the work.

4.4 Welfare Facilities:

The Contractor shall arrange for such facilities as provided for in the

Contract Labour (Regulation and Abolition) Act for the welfare and health of the labour employed on the work.

4.5 Precautions to be taken:

It will be entirely the Contractor's responsibility to provide personal protective equipment to his staff and labour force, take required steps to adequately safeguard the personnel carrying out the work and to ensure that the work is carried out in such a manner that maximum safety to the personnel is assured. The Contractor shall take insurance Policy covering all type of risks of all the personnel engaged by them for this Service Contract and the same shall be produced to the Engineer i/c for verification. The Insurance is to be taken from the date of commencement of work and same to be renewed as per validity.

4.6 Permission for Port Entry:

Free RFID Port Entry passes to the Contractor, his vehicle and his workmen during the period of contract will be issued, however contractor shall co-ordinate and arrange for the necessary documentation as per existing rules.

4.7 Power Supply:

The Port Authority will provide necessary power supply free of cost for the execution of the Project.

4.8 Major Port Authority Act - 1963, Indian Ports. Act -1908, Merchant Shipping Act - 1958, Dock Safety Regulations and all other relevant Laws on that behalf to the extent applicable in connection with the work to be carried out inside the Port.

4.9 The Contractor shall ensure smooth operation and maintenance of Computer and its peripherals throughout the contract period by continuously monitoring the condition and manpower systems during the operation and regular maintenance of these systems as and when required. Any abnormal condition noticed in any facility/system/equipment is to be immediately reported to the EIC or his representative.

4.10 The Contractor shall comply with all the **Central State and Municipal Laws and Rules** and shall be solely **responsible** for complying with the provisions of the **Contract Labour (Regulations & Abolition) Act, 1970** & the contract labour (Regulation & Abolition) Karnataka Rules 1974 and

rules there under and the enactments that may be applicable including ESI Act, the payment of wages act, Provident Fund Act, the Minimum Wages Act, the Factory's Act.

The Workmen Compensation Act or any other applicable legislation and the Municipal by-laws or other statutory Rules and Regulations whatsoever in force if these are applicable. Any obligations finding or otherwise missed under any statutory enactments, rules & regulations there under shall be the responsibility of the Contractor and the NMPA will take no responsibility for the same. The Contractor should take Workmen's Compensation Policy for his workers, who are not covered under ESI and submit the same to the EIC immediately after commencement of the work.

- 4.11** The Contractor is liable to pay all Statutory Compensation to the Labourers/persons engaged by him for the satisfactory execution of the works. If any claim is made against New Mangalore Port Authority on this work, the Port Authority shall have the right to deduct the same from the bill amount payable to the Contractor after verification of the validity and if admissible as per rules.
- 4.12** The Contractor shall indemnify the Port Authority for any claim made towards statutory default or any action due to non-fulfillment of the statutory obligations towards **E.P.F., ESI** etc.
- 4.13** The date of commencement of the contract shall be effective from the 7th day of issue of LOA.
- 4.14** No cooking is permitted inside the working area. If any personnel found in alcoholic condition on duty point such personnel shall be removed from the service by the Contractor and port entry pass shall be surrendered to the EIC or his representative.
- 4.15** Contractor's person shall not claim any type of compensation/ Absorption/Regularization/Benefit (Health related also) of service from this office under Industrial Dispute Act 1947 & Contract Labour Act 1970.
- 4.16** The Tenderer shall be responsible for taking precautionary measures for the safety of the workmen working under him and the responsibility arising due to any mishap during the execution of work, payment of any

compensation etc., lies entirely on the part of the Contractor. Safety Items required while working are to be provided by the Contractor.

4.17 If the performance of the Contractor is found to be unsatisfactory, NMPA shall give in writing by giving 30 days' notice period for improving the performance. In the event of continual unsatisfactory performance or noncompliance with any of the provisions of this contract, NMPA reserves the right to cancel the contract and forfeit the security deposit by giving 120 days' notice. The bidder shall give an undertaking that he will abide by the terms and conditions of the contract and employ required number of eligible personnel within the stipulated period mentioned in the LOA, failing which the contract terminated and the bidder **debarred from participating** in the tendering process at the port for a **period of 2 years** from the date of termination of contract.

4.18 The Contractor shall upon direction by the Engineer-in-charge remove forthwith from the works any persons employed for the execution of contract, who in the opinion of the Engineer-in-charge misconduct himself or is incompetent or is negligent in the proper performance of his duties or whose employment is otherwise considered by the Engineer-in-charge to be undesirable and such persons shall not be re-employed on the works without the written permission of the "Engineer-in-charge". Any person so removed from the works shall be replaced without delay by a competent substitute approved by the "Engineer-in-charge".

4.19 Labour:

- a. The Contractor shall make his own arrangements for the engagement of Technicians for doing the work at site or in respect of or in connection with the execution of work as also for the transport, housing, feeding and payment thereof.
- b. The Contractor shall not import, sell, give, barter or otherwise dispose of any alcoholic liquor, or drugs, or permit or suffer any such importation, sale, gift, barter or disposal by his sub-Contractor/s, his/their servants, agents or employees.
- c. The Contractor shall not give, barter or otherwise dispose of to any person or persons, any arms or ammunition of any kind or permit or suffer the same as aforesaid by his sub-Contractor/s, his/their

servants, agents or employees.

- d. The Contractor shall in all dealings with labour in his employment have due regard to all recognized festivals, days of rest and other customs.
- e. In the event of any outbreak of illness of an epidemic nature, the Contractor shall comply with and carry out such regulations, orders and requirements as may be made by the Government, or the local medical or sanitary authorities for the purpose of dealing with and overcoming the same.
- f. The Contractor shall at all times take all reasonable precautions to prevent any unlawful, riots or disorderly conduct by or amongst his employees/labour and for the preservation of peace and protection of persons and property in the neighborhood of the works against the same.
- g. The Contractor shall at all times during the continuance of the contract comply fully with all existing Acts, Regulations and bye laws including all statutory amendments and reenactment of State or Central Government and other local authorities and any other enactments and acts that may be passed in future either by the State or the Central Government or local authority, including Indian Workmen's Compensation Act, Contract labour (Regulation and Abolition) Act, Minimum wages Act, Provident Fund Regulations, Employees Provident Fund Act etc., and sanitary arrangement for the said Act. Health and Sanitary Arrangements for workmen. Insurance and other benefits, etc., and shall indemnify and keep the Employer indemnified in case any proceedings are taken/commenced by any authority against the Employer for any contravention of any of the laws or scheme by the Contractor. If as a result of Contractor's failure, negligence, omission, default or non-observance of any provisions of any laws, the Employer is called upon by any authority to pay or reimburse or required to pay or reimburse any amount, the Employer shall be entitled to deduct the same from any moneys due or that may become due to the Contractor under this contract or any other contract or otherwise recover from the Contractor any sums which the Employer is

- required or called upon to pay or reimburse on behalf of the Contractor. All registration and statutory inspection fees in respect of his work pursuant to the contract shall be paid by the Contractor.
- h. The Contractor shall maintain the records prescribed under ESI regulations and make the contribution towards ESI in respect of persons employed by the Contractor. The Contractor shall also make available such records for inspection by ESI inspector during the inspection and furnish copies of all such records to the Employer regularly.
 - i. The Contractor shall pay the labourers engaged by him on the work not less than a fair wage, which expression shall mean, whether for time or piece work, rates of wages as may be fixed by the Public Works Department as fair wages for Mangalore District payable to the different categories of labourers or those notified under the Minimum Wages Act for corresponding employees of the Employer whichever may be higher. The minimum wages shall be paid per worker per day as per prevailing wages.
 - j. The Contractor shall notwithstanding the provisions of any contract to the contrary, cause to be paid a fair wage to the labourers indirectly engaged by sub-Contractors in connection with the said works as if the labourer had been directly employed by him.
 - k. The Contractor shall, before he commences the work, display and correctly maintain in a clean and legible condition at a conspicuous place on the site notices in English and in a local language spoken by the majority of the workers, stating therein the rate of wages which have been fixed as fair wages and the hours of work for which such wages are earned and send a copy of such notices to the Employer.
 - l. The Contractor shall maintain records of wages and other remuneration paid to his employees in such form as may be convenient and to the satisfaction of the Employer and the Conciliation Officer(Central), Ministry of Labour, Government of India, or such other authorized person appointed by Central or State Government and the same shall inter alia include the following particulars of each worker;

- i) Name, works number and grade.
 - ii) Rate of daily or monthly wage
 - iii) Nature of work on which employed
 - iv) Total number of days worked during each wage period.
 - v) Total amount payable for the work during each wage period.
 - vi) All deductions made from the wage with details in each case of the ground for which the deduction is made.
 - vii) Wage actually paid for each wage period.
- m. The Contractor shall provide a wage slip for each worker employed on the works.
- n. The wage records and wage slips shall be preserved by the Contractor for minimum period of 12 months after the last entry or such time as the Employer may fix in that behalf.
- o. The Contractor shall allow inspection of the aforesaid Wage Records and Wage slip to the Employer at a convenient time and place after notice is received by him from the Employer demanding such inspection.
- p. The Employer or any other person authorized by them on their behalf shall have power to make inquiries with a view to ascertaining and enforcing due and proper observance of the Fair Wages Clauses. The Employer shall also have the power to investigate into any complaint regarding any default made by the Contractor in regard to such provision.
- q. A workman shall be entitled to be represented in any investigation or enquiry against him by;
 - i) An officer of a registered Trade Union of which he is a member.
 - ii) An officer of a federation of Trade Unions to which the Trade Union referred to in previous sub-clause is affiliated.
 - iii) Where the worker is not a member of any registered Trade Union by an officer of a registered Trade Union connected with or by any other workmen employed in the industry in which the worker is employed.
 - iv) The Contractor shall be entitled to be represented in any

investigations or enquiry under this clause by an officer of an Association of Employers of which he is a member.

- v) No party shall be represented by a legal practitioner in any investigation or enquiry under this clause unless all parties agree.
- r. The Contractor shall comply with all the precautions as required for the safety of the workmen by I.L.O convention as far as they are applicable to the contract. The Contractor shall provide all necessary safety appliances goggles, helmets, masks, etc. to the workmen and the staff.
- s. Contractor shall furnish particulars of all labour proposed to be employed by him on the works in NMPA area indicating their names, father's name, present address, permanent address and two photographs. This is in addition to other requirements regarding security passes etc. if any.
- t. The engineer-in-charge shall have the right to withhold for the benefit of the worker or workers from the money due to the Contractor any sum required or estimated to be required for making good the loss suffered by a worker or workers by reason of non-fulfillment of the conditions of the contract, non-payment of wages or of deductions made from his or their wages which are not justified by the terms of the contract or non-observance of the regulations.
- u. For work carried out in the vicinity of any wharf or quay, the Contractor shall abide by all the provisions of the Dock Workers (Safety, Health and Welfare) Scheme, 1961.
- v. The staffs deployed for the upgradation of LAN shall be as per the qualifications prescribed at Technical compliance matrix of the tender document. If any staffs deployed under contract misbehaves/ doesn't obey the orders of EIC, the contractor shall be intimated to issue warnings to the concerned staff. If the concerned staff doesn't change his attitude of disobedience/ misbehavior; a second notice shall be served to the contractor, to terminate the concerned staff. The contractor upon receipt of the second notice shall immediately remove the staff from the contract and provide a replacement within

3 days from the date of issuance of the second notice. Wages pertaining to the concerned staff shall not be paid during this period. Contractor's staffs shall not claim any type of compensation/ Absorption/Regularization/Benefit (Health related also) of service from this office under Industrial Dispute Act 1947 & Contract Labour Act 1970. Same shall be ensured by the Contractor. Further, the contractor shall ensure that, the deployed staffs are not affiliated to any unions etc.

4.20 Transportation.

The contractor shall make his arrangements for the transport within the premises to carry the material during the execution of work.

The contractor shall not use Port Vehicle to carry out the work without the prior approval of the EIC.

4.21 Confidentiality

The Contractor shall treat the details of the work, Data Centre/ Data/Security Infrastructure of the Port as Private and confidential, and shall not publish or disclose the same or any particulars thereof in any trade or technical paper or elsewhere without the previous consent in writing of the Employer. The contractor shall sign Non-Disclosure Agreement before the commencement of the Contract.

4.22 Existing IT Infrastructure:

The existing Local Area Network was established in the year 2007. It consists of 1No of Core switch (Nortel ERS 8600), 3No of Distribution switch (Nortel ERS 5530), 8No of Edge Switch – 48 Port, 42No of Edge switch – 24 Port. The link between the core switch and the distribution switch is 10 Gbps and distribution to edge switches is 1Gbps, and 15Kms of OFC laid. Above switches are connected through single mode OFC cable. The Pictorial representations is shown below:

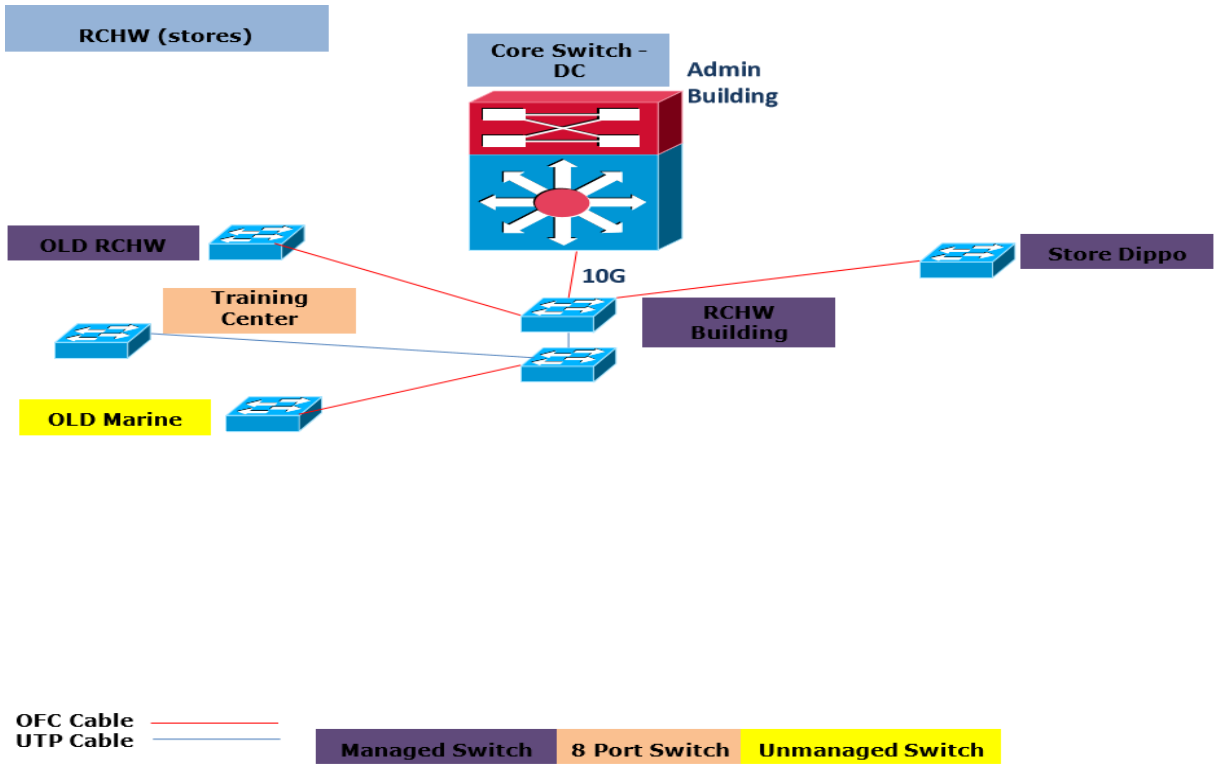
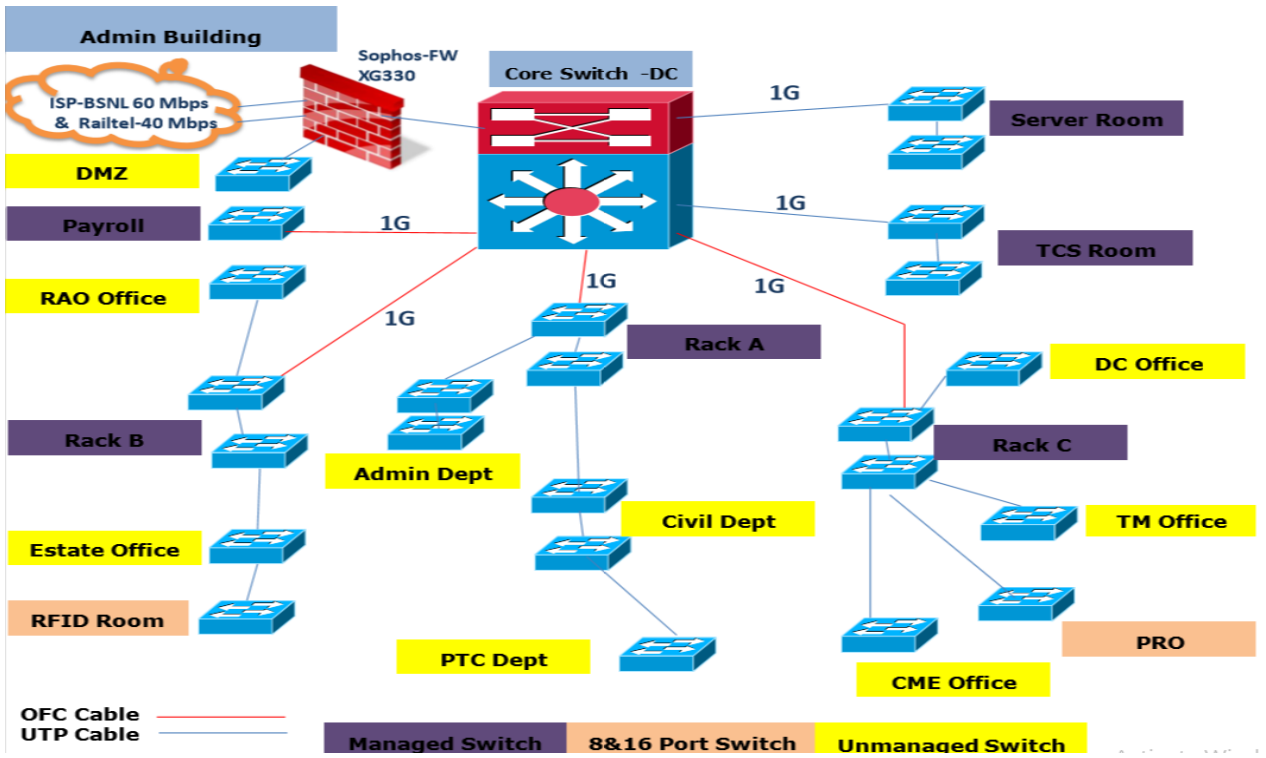

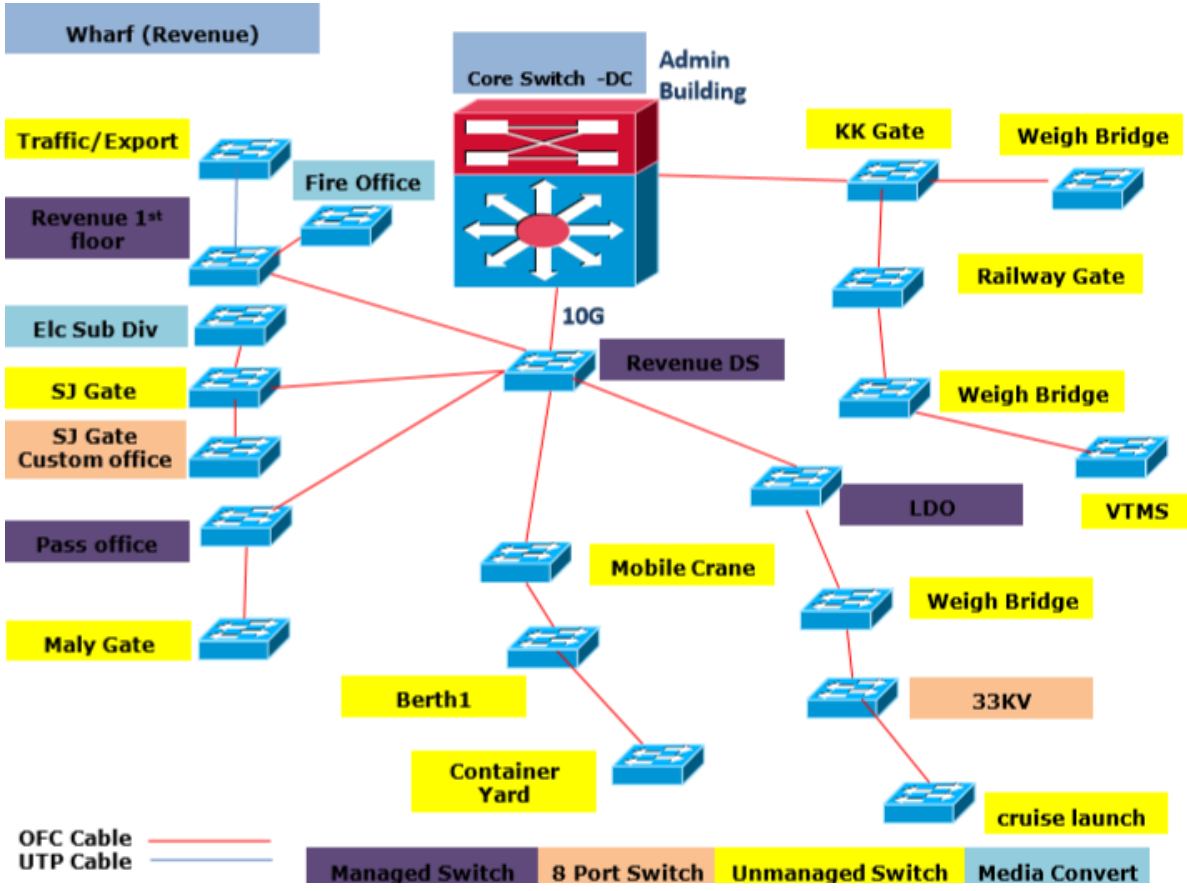
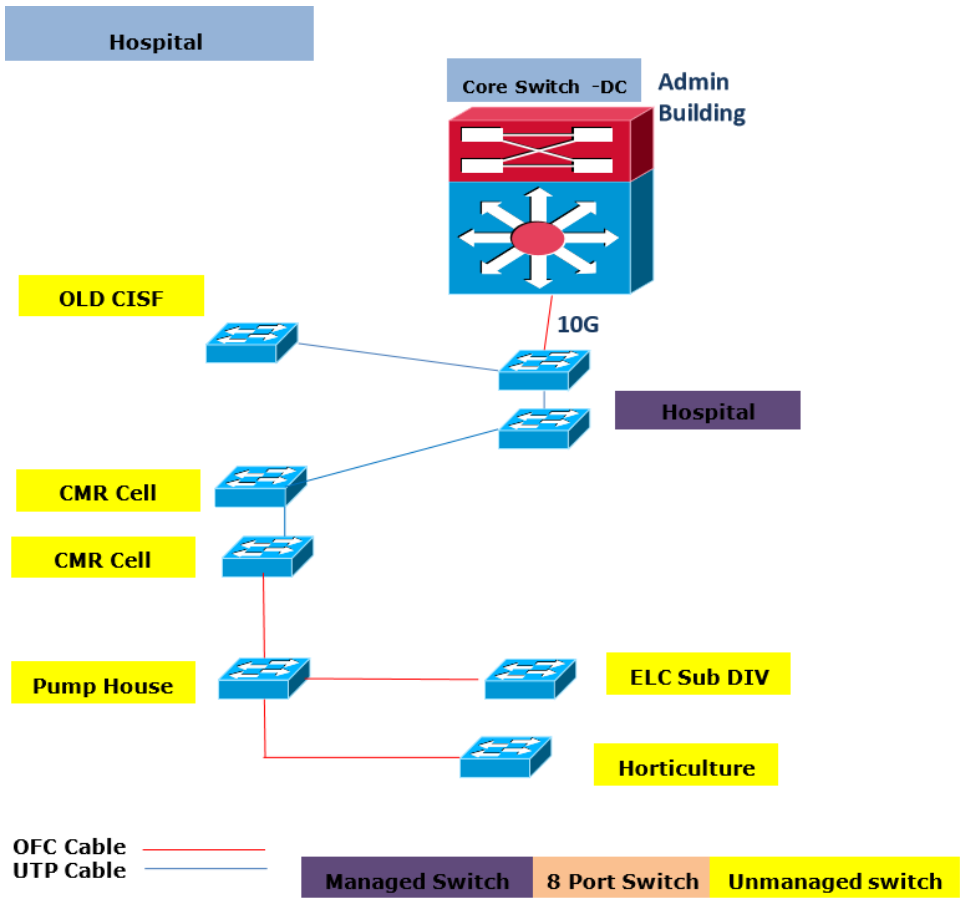

5. SCOPE OF WORK

The NMPA plans to upgrade the Local Area Network so as to provide high connectivity, scalable, reliable, secure and robust network architecture. The SI will provide latest technology benefits like data security, network security, guaranteed application response, reliability etc.

The network infrastructure should offer minimal downtime due to failure or breakdown of links or devices and even for planned outages. The redundant network backbone shall ensure that there is no delay in the flow of information and data, irrespective of file size or amount of network traffic at any given point in time.

The network shall be scalable as well as flexible so that future expansions and enhancements can be made in keeping with the rapid growth of technology and growing demands. Future augmentations and expansions should not require upgrade of any of the active components to be deployed now.

5.1 Detailed Scope of work:

- i. Supply of items as per BoQ and Specifications.
- ii. Configuration, Physical installation, Cable laying, and powering of all Active and Passive, Components, Integration and Interfacing with IT Systems of the Port.
- iii. Configuration and installation of Active Directory, Point to Point Wi-Fi Connections, Network Access Control, and integration of Active Directory with Oracle SSO for ERP applications and performing user acceptance testing. DHCP will be worked through AD server.
- iv. Configuration of VLANs and Inter VLAN as required.
- v. After installation and configuration of each and every subsystem, integrating various systems and providing various services, tests shall be conducted for system performance as a whole. Commissioning shall mean end-to-end commissioning of the network with testing of live applications. Penta testing and OTDR to be for full network and Fluke test report to be submitted before Go-Live. Time schedule, Test parameters, commitments etc shall be submitted along with implementation plan.
- vi. Upon Self testing and Commissioning, the system shall be offered for inspection by the Consultants engaged by the Port to check for Compliance.
- vii. Any structure, permanent or temporary, dismantled or destroyed during the execution of the work shall be refilled/remake or restore to its original condition by the contractor at his own cost Any extra electrical points and data points required in the server room shall be provided by the contractor at his own cost.
- viii. Carry out Penta-scanning of each and every node of the LAN Network and OTDR testing of fiber cores. OTDR test is required for Existing & New OFC Infra.
- ix. Submission of Implementation plan/Resource plan/Network Architecture before installation, configuration and commissioning.
- x. Configure the Security devices in line with NMPT security policy.
- xi. Provide Network Administration and management support.
- xii. Supply and erection of route markers for the existing OFC network, labelling and dressing of the cables.

- xiii. The bidder is responsible to protect the entire System, virtual machines etc against all kinds of IT Security threats. The utmost care shall be taken while configuring the hardware, software, to see that vulnerabilities and backdoors, Trojans are not present in the Hardware or the Software supplied by the bidder.
- xiv. Implementation of IPV6, single sign on, Network access control, Patch Management System to maintain and push relevant patches to the client windows/linux systems. Inventory Management of digital assets.
- xv. IT Security Audit by the CERT-In empaneled vendor and submission of certificate before commissioning of the Network. Accordingly recommendations/vulnerabilities if any shall be implemented by the contractor before commissioning, and a certificate in this regard shall be submitted by the contractor. The OEM patches/updates shall be applied in the network after thorough verifications and validations. IT Security audit shall be conducted by the bidder whenever there is a major change in the Network. Vendor shall protect Servers/ Switches/ NMS/DNS/NAS/VMs/Storage etc., from all kinds of cyber-attacks/viruses/malwares/ransomwares etc. Necessary Licenses has to be provisioned while submitting bid.
- xvi. Renewal of Licenses/subscriptions.
- xvii. Hardening of all devices and Active Directory, NAC, DNS as per guidelines of OEM's such as Microsoft.
- xviii. High Availability for critical components such as AD/DNS/NAC/NMS shall be provisioned by the bidder.

5.1.1 **Active Directory**

- i. The main function of Active Directory is to enable administrators to manage permissions and control access to network resources. Active directory is required for local domain specific to NMPA site.
- ii. Install and configure Forest, Add users, group
- iii. Define security policies
- iv. Define AD & BD
- v. Create forest, domain, DNS, and organizational unit design.
- vi. Create a site and site link design.
- vii. Assess hardware requirements.

- viii. Deploy the forest root domain.
- ix. Deploy regional domains.
 - x. Raise the domain and forest functional levels.
- xi. Protection against malwares, cyber threats, vulnerabilities

5.1.2 **DNS**

- i. Common internal and external DNS namespace
- ii. Private internal DNS namespace
- iii. Troubleshooting multi-domain environments
- iv. Configure clients
- v. DNS mapping of multiple ISPs
- vi. Add resilience to loss of network connection
- vii. Configure active directory DNS
- viii. Protection of DNS from cyber threats, vulnerabilities, malwares

5.1.3 **NMS**

- i. Seamless discovery of physical and virtual network components
- ii. Real-time network performance management
- iii. Network fault management and alert on email over SMTP
- iv. Automated tasks with workflows
- v. Configuration and change management
- vi. IP and switch port management
- vii. Network topology diagrams for seamless visualization
- viii. Historical stats analysis with holistic reports
- ix. All-encompassing dashboards for simplified network management

5.1.4 **Storage**

- i. Consolidates storage devices making management relatively easy
- ii. Utilizes storage devices effectively by pooling them
- iii. Enhances performance by reducing storage latency
- iv. Improves application availability through redundancy
- v. Simplifies data backup (without server interaction)
- vi. Storage allocation as per the requirements
- vii. Storage is for centralized and backup
- viii. Antivirus /cybersecurity

5.2 **PROJECT MANAGEMENT ACTIVITIES**

The bidder shall submit detailed plan for the following in the technical bid:

- a. Detailed project plan.
- b. The Resource Plan
- c. Management Reporting
- d. Issue Management
- e. Risk Management
- f. Patch Management

The bidder shall formulate an overall project plan to carry out all the activities listed in the RFP. A detailed work plan shall be created for each Milestone separately. These shall be discussed in weekly status meetings to ascertain the progress of the Project. The project schedule specified in the agreement shall be strictly adhered to. The bidder shall provide detailed schedule in the technical bid. The bidder shall submit PERT chart in this regard. The resource plan will be prepared by the bidder, based on its assessment of the skills required during different phases of the project. The bidder is required to Staff the project so as to complete all the activities within the timelines expected by NMPA. Although the SI is free to work out its own resource loading and the skill deployment plan, NMPT will use this to judge whether the SI is planning to Staff the project to ensure timely completion of the project or not. NMPT will have the right to ask for changing the resource plan during the project execution stage, if it finds that the project is either under Staffed or over staffed with inadequate skills (to ensure that inadequate skills are not substituted by more people)

5.3 **Scope of Documentation:**

- a. Providing original manuals of all Hardware items supplied.
- b. Test parameters, commitments etc for acceptance testing to be enclosed along with Implementation plan.
- c. Documentation on Equipment/ rack layout plan and connectivity Diagram, Network Architecture, Security Architecture
- d. Technical write up of the network design and functioning, System and Network architecture diagram, Active and Passive components configuration details, Security implementation.

- e. Network configuration details (port wise) with IP address, subnet, VLAN, port description, etc for all active components.
- f. Security implementation including VPNs, rules, IDS/IPS, ACL details etc.
- g. Detailed Operator manuals for all the active components of the Network.
- h. Acceptance test reports, performance test reports of networking components, load test reports.
- i. To provide detailed Project document report with connectivity diagrams (Physical and Logical) including: Raceway/pathway diagram, heat maps, Cable and Fibre patching details, Naming and labelling details, Cable scanning and test results.
- j. Documentation shall be submitted in both Softcopy and Hard Copy.

5.4 **Training:**

The bidder should do hand holding activities to the users whenever required. The bidder shall train the authorized engineers as and when required so as to utilize the Systems properly. The SI shall provide training to the users for the configurations/transactions that are changed/enhanced/introduced. Training to be given for the operation of the system on account of changes made by way of incident resolution or change order implementation for getting the operational acceptance. The bidder shall impart necessary training to the identified engineers of the Port along with training materials.

5.5 **Warranty Services/defect liability.**

- a. The bidder shall obtain and provide to NMPA product warranty on the hardware supplied through this tender for a period of three years from the date of commissioning/go live of the network.
- b. The bidder shall provide the comprehensive manufacturer's warranty in respect of proper design, quality and workmanship of all hardware, equipment, accessories etc. covered by the RFP. SI must warrant all hardware, equipment, accessories, spare parts, software etc. procured

and implemented as per this RFP against any manufacturing defects during the warranty period.

- c. The bidder shall provide the performance warranty in respect of performance of the installed hardware and software to meet the performance requirements and service levels in the RFP.
- d. Mean Time Between Failures (MTBF) - If during entire contract period, any equipment has a hardware failure on four or more occasions in a period of less than three months or six times in a period of less than twelve months, it shall be replaced by equivalent or higher-level new equipment by the bidder at no cost to NMPA. However, if the new equipment supplied is priced lower than the price at which the original item was supplied, the differential cost should be refunded to NMPT. For any delay in making available the replacement and repaired equipments for inspection, delivery of equipments or for commissioning of the systems or for acceptance tests / checks on per site basis, NMPT reserves the right to charge a penalty.
- e. During the warranty period the bidder shall maintain the systems and repair / replace at the installed site, at no charge to NMPA, all defective components that are brought to the bidder's notice.
- f. The SI shall carry out Preventive Maintenance (PM), including cleaning of interior and exterior, of all hardware and testing for virus, if any, and should maintain proper records at each site for such PM. Failure to carry out such PM will be a breach of warranty and the warranty period will be extended by the period of delay in PM.
- g. The bidder shall monitor warranties to check adherence to preventive and repair maintenance terms and conditions.
- h. The bidder shall ensure that the warranty complies with the agreed Technical Standards, Security Requirements, Operating Procedures, and Recovery Procedures.
- i. The bidder shall have to stock and provide adequate onsite and offsite spare parts and spare component to ensure that the uptime commitment as per SLA is met.
- j. The bidder component that is reported to be down on a given date should be either fully repaired or replaced by temporary substitute (of

equivalent configuration) within the time frame so as to conform to SLAs.

- k. The Contractor shall be responsible for all the Defects and deficiencies, except usual wear and tear. Without prejudice, the Contractor shall repair or rectify all Defects and deficiencies observed by the Authority’s Engineer during the Defects Liability Period within a period of 15 (fifteen) days from the date of notice issued by the Authority’s Engineer in this behalf, or within such reasonable period as may be determined by the Authority’s Engineer at the request of the Contractor, in accordance with Good Industry Practice. The Defects Liability Period/warranty shall be deemed to be extended till the identified Defects have been remedied

5.6 Severity & Resolution: The bidder shall be responsible to ensure an availability of 99.999% for the entire Network. The successful bidder will adhere to the following Service Level Agreements (SLAs).

No	Severity Levels	Description	Support Coverage	Response Time	Resolution Time	Penalty for every hour beyond Resolution Time
1	Business standstill (Critical)	The network is unavailable and blocks the execution of the primary business process.	24/7 Support	30 Min	1 Hour	10,000.00

2	Performance Degradation / Partial impact (High)	Network is Partially unavailable and blocks normal productivity of the Port	24/7 Support	2 Hours	3 Hours	6,000.00
3	Regular default category (Medium)	A non-business critical part of the Network is unavailable. The majority of the functions operate normally.	8x5 business hours	4 Hours	1 Day	3000.00
4	No immediate impact to business (Low)	The Network is used by a very few users & the unavailability will not affect business.	8x5 business hours	6 Hours	2	1000.00

Table 2: SLAs

5.7 Technical Specification Compliance Matrix:

Sr. No.	Description	Specifications	Compliance (Yes / No)?	Offered Brand	Specification Sheet with Page Number
PASSIVE COMPONENTS					
A	Passive Network				

1	Fiber Optic Cable, 12cores-fiber, OS2, loose tube, dry – Outdoor, Armoured OFC with LSZH. Single mode FRP, Single drum, Single OEM.	Cable Type - Loose tube Fibers per Subunit, quantity - 12 Subunit Type - Gel-free Total Fiber Count - 12 Diameter Over Jacket - 6.4 mm 0.252 in Minimum Bend Radius, loaded - 139.7 mm 5.5 in Minimum Bend Radius, unloaded - 129.5 mm 5.098 in Tensile Load, long term, maximum - 650 N 146.126 lbf Tensile Load, short term, maximum - 1250 N 281.011 lbf			
2	LIU	12F, 1U, LC SM OS2 , Loaded with Pigtails, Splice tray, adapter & splice protectors			
3	LIU	24F, 1U, LC SM OS2 , Loaded with Pigtails, Splice tray, adapter & splice protectors			
4	Fiber Patch Cords	Single mode 3mtr length			
5	Patch Panel	Cat 6, 24-port Loaded Modular Straight Jack Panel with labels, clear label covers and rear cable support bar, Height, 1U			
6	CAT6 Cable Box	Category 6 U/UTP Cable, low smoke zero halogen, gray jacket, 4 pair count, 1000 ft (305 m) length			
7	Conduit	PVC Conduit 30mm			
8	Conduit	HDP Conduit 1"			
9	Capping	Case & Capping Patti 1.5"			
10	Capping	Case & Capping Patti 1"			
11	GI Pipe	GI Pipe			

12	Network Rack	27U Rack Frame/ 800X1000/Steel/NRS/Casters Type 3/Levellers/19" Adapter kit / Loops/ Glass Door/800/27U/NRS/ Perforated Door/27/800/Dual/NRS/Swing Handle /Mechanical Lock / Three Point / Common Key/Die Cast Metal/Side Panels/1000 27U/Vented/NRS x 2nos /Horz. 1 U closing type cable Managerx 6nos/1U /Loop/Shelf/ 1000/ITE / Server Rack Air Circulation module/Tower Mount/360CFM/ Server / IT Rack mount power distribution unit, 1Ph, 230V, 32A, 50/60Hz, Zero U standard with 12 X Indian Round Pin 5/15A, (Inlet Plug Not Installed, Recommended IEC30932A 2P +E), 16A MCB X 2 Circuits- PDU Rating 7.3KVA/Bottom feed-3Mt/ Black x 2Nos			
13	Faceplate	CAT6 Single I/O Face Plate			
14	Backbox	CAT6 Single I/O Face Plate Back Box			
15	Patch Cords	2Mtr CAT6 UTP Patch Cords			
B	NETWORK ACTIVE				
16	Core Switch	40G Backbone			
	Hardware & Interface requirements	The Switch should have minimum 2 Supervisor/Management module and 8 Payload I/O slots. The switch shall be populated with full capacity of power supplies, Fans, Supervisor/ Fabric cards /Management modules, etc. from day1. Required Line cards, fiber Transceivers for uplinks shall be as per design/BOQ			
		16 GB Memory on Management Module/Supervisor and minimum 8 MB Packet buffer size/module. Buffer memory is per module. The vendor can propose higher values.			
		Switch should support high availability Configuration with vPC or VSX or VSS or equivalent technology, required modules and cables for the same has to be provided from day 1. Switch should also support Multi-chassis Link Aggregation or equivalent.			

		Switch should have Internal Redundant Power Supplies and Fans			
	Performance Requirements	The switch shall have switching capacity of minimum 20 Tbps or more			
		Should support System Throughput Capacity minimum 8 Bpps			
	Layer 2 Switching	Should support at least 32,000 MAC addresses, 50,000 IPv4/v6 Routing Table size including multicast routing entries			
		Switch should support Multiple VLAN Registration Protocol (MVRP) or equivalent			
	Layer 3 Routing	Shall support Layer 3 routing features including RIPv2, RIPv6, OSPF, OSPFv3, BGP, MP-BGP or equivalent, VRRP, PIM-DM, PIM-SM, Policy based routing, VRF-Lite, VXLAN, EVPN. If any licenses are required, it shall be included from Day 1			
	Quality of Service (QoS)	Switch should support Layer 2 and Layer 3 QoS			
		Switch should support Strict Priority (SP) and SDWRR/DWRR or equivalent scheduling methods			
		Switch should support Software defined network (SDN) capability by supporting multiple programmatic interfaces including REST APIs, Python scripts, ANSIBLE playbooks or equivalent			
	Multicast Support	Switch should Support minimum 5000 IGMP Groups			
		Support for PIM-SM, PIM-SSM, PIM-DM from day 1			
	System Management & Administration				
		Switch should support IPv6 Management including Neighbour discovery, Logging, Telnet/SSH, Web/SNMP, NTP/SNTP and DNS			
		Switch should support configuration and image rollback			
		Should support DHCP Server, Client and Relay			
		Switch should support local and remote port mirroring			

	Security Features	Switch should support IPv4/v6 Access control lists (ACLs) with minimum 5000 ACL Entries per line card.		
		The switch should support 802.1x Authentication and MAC Authentication Bypass for clients which do not support 802.1x		
		Switch should have integrated module or equivalent technology for platform integrity check and to ensure the boot process is from trusted source		
		The switch should support Web Authentication for Guest users and URL Redirect to redirect all the http access to predefined URL.		
		The switch should support VLAN Assignment – dynamically assign VLAN assigned based on the client role.		
		The switch should support Downloadable ACLs – These ACLs (access policies) are not defined on the switch, they are downloaded from Policy engine during authentication and applied on the switch.		
		Shall support advanced telemetry and automation features to easily identify and troubleshoot network, system, application and security related issues		
		Common Criteria Certified (EAL/NDPP) from Day 1 (Proof shall be submitted).		
		The switch should support Change of Authorization – Any change in access policy can be pushed to all the clients dynamically from NAC server , the clients need not re-authenticate to get the new access policies.		
		Proposed Core, Distribution, access switches and transceivers should from same OEM for interoperability and management.		
	Power Cords	Power Cables		
	Modules	12p 40G/100G QSFP28 Module		
	Modules	48p 10G/25G SFP28 Module		
	Cable	40G QSFP+ to QSFP+ 3m DAC Cable		

	Cable	10G SFP+ to SFP+ 3m DAC Cable			
	Warranty - 24X7 WITH 6 CTR	Switch should be provided with hardware replacement warranty and ongoing software upgrades for all major and minor releases for a period of Total 3 years.			
	Additional Support / Warranty	Additional 4 years warranty / support pack			
17	Distribution Switch	40G & 10G Support			
	Hardware & Interface Requirements	The switch should be an enterprise class stackable switch with minimum (48) 10GbE/25GbE / equivalent ,1GbE SFP+/SFP ports, (6) 40GbE QSFP+ ports. The switch shall be populated with required Fiber Transceivers for uplinks from Day 1 (as per design/BOQ)			
		Switch shall have minimum 16 GB RAM Memory and 16MB of Buffer Memory			
		Switch should have Dual Internal RPS and fans.			
	Performance Requirements	Should support wire speed switching throughput of minimum 2400 Gbps			
		Should support distributed Layer 2 and Layer 3 forwarding of minimum 1800 Mpps			
		Switch should support minimum 95000 MAC addresses per system			
	Layer 3 Routing				
		Switch should support Layer 3 routing features including RIPv2, RIPv6, OSPF, OSPFv3, BGP, MP-BGP, VRRP, Policy based routing, VRF from day 1. If any licenses are required, it shall be included from Day 1			
	QoS	Switch should support Layer 2 and Layer 3 QoS			
		Switch should support Strict Priority (SP) and SDWRR/DWRR or equivalent scheduling methods			
	Multicast Support	Should support IGMP v1/v2/v3, PIM-SM, PIM-SSM , PIM for IPv6 multicast & PIM-DM from day 1			
		Support minimum 4000 IGMP groups			
		Should support IPv6 multicast snooping MLD v1/v2			

		Should support Multicast Source Discovery Protocol (MSDP)			
	Security Features	Switch should support IPv4/v6 Access control lists (ACLs) with minimum 4000 ACL Entries.			
		Switch should have integrated module or equivalent technology for platform integrity check and to ensure the boot process is from trusted source			
		Switch should support Multiple VLAN Registration Protocol (MVRP) or equivalent			
		Shall support advanced telemetry and automation features to easily identify and troubleshoot network, system, application and security related issues			
		Common Criteria Certified (EAL/NDPP) from Day 1 (Proof shall be submitted)			
	HA	Shall have capability to form a single, logical virtual unit across two active switches with dual active control plane, for high availability, non-disruptive fast upgrades, multi-chassis link aggregation and simplified management			
	System Management & Administration	SNMP v2c/v3, SSHv1/SSHv2 Secure Shell, RADIUS/TACACS+ for switch management security, RMON and sFlow/Netflow or equivalent for advanced traffic monitoring			
		The Switch should support Unidirectional Link Detection (UDLD) or equivalent.			
		Software defined network (SDN) capability by supporting multiple programmatic interfaces like REST APIs, Python scripts, ANSIBLE playbook or equivalent			
		Shall be built on a modular, micro-services based OS architecture allowing individual software modules to be independently upgraded for higher availability.			
		Proposed Core, Distribution, access switches and transceivers should from same OEM for interoperability and management.			

	Allied Accessories	To be supplied along with all allied accessories (like power supplies, rack mounting kits, power cords, connectors, cables, licenses, etc) as per project and site requirements for the full operations of the device in line with the requirements enumerated herein, even if details are not indicated under Section-III (BoQ/BoM)			
	Cable	40G QSFP+ to QSFP+ 3m DAC Cable			
	Cable	10G SFP+ to SFP+ 3m DAC Cable			
	Warranty - 24X7 WITH 6 CTR	Switch should be provided with hardware replacement warranty and ongoing software upgrades for all major and minor releases for a period of Total 3 years.			
	Additional Support / Warranty	Additional 4 years warranty / support pack			
18	24 Port Edge Switch	10G Support			
	Hardware & Interface Requirements	The switch should be an enterprise class stackable switch with minimum 24 x 10/100/1000 Ethernet Port and 4 x 1/10G SFP+ ports. The switch shall be populated with required Fiber Transceivers for uplinks from Day 1 (as per design/BOQ)			
		The switch shall have minimum 1GB RAM and 8MB packet buffer memory			
		Switch should have Dual Internal RPS			
	Performance Requirements	Minimum Switching bandwidth shall be worked as ((Total number of 10G Ports + Total number of 1G ports + Stacking BW) x 2 Full Duplex)) 228 Gbps or above for line rate performance. Offers not meeting this calculation shall be rejected.			
	Layer 2 Switching	Switch should support minimum 10000 MAC addresses per system			
		Switch should support Jumbo frames – 9,000 bytes			
		Switch Should support minimum 2000 VLAN's and 4094 VLAN ID's			
		Switch Should support Port-based VLAN and MAC-based VLAN			
		Switch should support Private VLAN (PVLAN)			

	Layer 3 Switching	The switch should support IPv4 and IPv6 Static Routing, OSPF, Policy Based Routing, PIM Multicast Routing, VRRP, VxLAN Encapsulation/Tunneling Protocol from day 1. Provision shall be made for static and dynamic routing.			
	QoS	Switch should support Layer 2 and Layer 3 QoS			
		Switch should support Marking, policing, and shaping			
		Switch should support setting of Class of Service (CoS) IEEE 802.1p priority tag based on IP address, IP Type of Service (ToS), Layer 3 protocol, TCP/UDP port number, source port, and DiffServ			
	Multicast Support	Should support IGMP v1/v2/v3, PIM-SM, PIM-DM, IPv6 multicast snooping MLD v1/v2 from day 1			
		Support minimum 1000 IGMP groups			
	System Management & Administration	Switch should support IPv6 Management including Neighbour discovery, Logging, Telnet/SSH, Web/SNMP, NTP/SNTP and DNS			
		Switch should support configuration and image rollback			
		Should support DHCP Server, Client and Relay			
		Switch should support sFlow flow management or equivalent.			
		Switch should support local and remote port mirroring			
		The Switch should support Uni-directional Link Detection (UDLD) or equivalent.			
		Switch should support the IEEE 802.3az standard for Energy Efficient Ethernet (EEE) functionality, reducing power consumption of copper ports during periods of low link utilization			
		Switch should support REST APIs or equivalent for programmability			
	Security Features	Switch should support IPv4/v6 Access control lists (ACLs) with minimum 1000 ACL Entries.			

		The switch should support 802.1x Authentication and MAC Authentication Bypass for clients which do not support 802.1x			
		Switch should have integrated module or equivalent technology for platform integrity check and to ensure the boot process is from trusted source			
		Common Criteria Certified (EAL/NDPP) from Day 1 (Proof shall be submitted)			
		The switch should support Web Authentication for Guest users and URL Redirect to redirect all the http access to predefined URL.			
		Switch should support Multiple VLAN Registration Protocol (MVRP) or equivalent			
		The switch should support Downloadable ACLs – These ACLs (access policies) are not defined on the switch, they are downloaded from Policy engine during authentication and applied on the switch.			
		The switch should support Change of Authorization – Any change in access policy can be pushed to all the clients dynamically from NAC server , the clients need not re-authenticate to get the new access policies.			
	HA	Switches must support switch virtualization/stacking feature to extend the control plane across multiple (minimum 8) active switches forming a single virtual switching fabric. Any modules/cables required for the same shall be provided from Day 1			
		Proposed Core, Distribution, access switches and transceivers should from same OEM for interoperability and management.			

	Allied Accessories	To be supplied alongwith all allied accessories (like power supplies, rack mounting kits, power cords, connectors, cables, licenses, etc) as per project and site requirements for the full operations of the device in line with the requirements enumerated herein, even if details are not indicated under Section-III (BoQ/BoM)			
	Warranty - 24X7	Switch should be provided with hardware replacement warranty and ongoing software upgrades for all major and minor releases for a period of Total 3 years.			
	Additional Support / Warranty	Additional 4 years warranty / support pack			
19	48 Port Edge Switch	10G Support			
	Hardware & Interface Requirements	The switch should be an enterprise class stackable switch with minimum 48 x 10/100/1000 Ethernet Port and 4 x 1/10G SFP+ ports. The switch shall be populated with required Fiber Transceivers for uplinks from Day 1 (as per design/BOQ)			
		The switch shall have minimum 1GB RAM and 8MB packet buffer memory			
		Switch should have Dual Internal RPS			
	Performance Requirements	Minimum Switching bandwidth shall be worked as ((Total number of 10G Ports + Total number of 1G ports + Stacking BW) x 2 Full Duplex)) 276 Gbps or above for line rate performance. Offers not meeting this calculation shall be rejected.			
	Layer 2 Switching	Switch should support minimum 10000 MAC addresses per system			
		Switch Should support minimum 2000 VLAN's and 4094 VLAN ID's			
		Switch Should support Port-based VLAN and MAC-based VLAN			
		Switch should support Private VLAN (PVLAN)			

	Layer 3 Routing	The switch should support IPv4 and IPv6 Static Routing, OSPF, Policy Based Routing, PIM Multicast Routing, VRRP, VxLAN Encapsulation/Tunneling Protocol from day 1. Provision shall be made for static and dynamic routing.			
	QoS	Switch should support Layer 2 and Layer 3 QoS			
		Switch should support Strict Priority (SP)			
		Switch should support Marking, policing, and shaping			
		Switch should support setting of Class of Service (CoS) IEEE 802.1p priority tag based on IP address, IP Type of Service (ToS), Layer 3 protocol, TCP/UDP port number, source port, and DiffServ			
	Multicast Support	Should support IGMP v1/v2/v3, PIM-SM, PIM-DM, IPv6 multicast snooping MLD v1/v2 from day 1			
		Support minimum 1000 IGMP groups			
	System Management & Administration	Switch should support IPv6 Management including Neighbour discovery, Logging, Telnet/SSH, Web/SNMP, NTP/SNTP and DNS			
		Switch should support configuration and image rollback			
		Should support DHCP Server, Client and Relay			
		Switch should support sFlow flow management			
		Switch should support local and remote port mirroring			
		The Switch should support Uni-directional Link Detection (UDLD) or equivalent.			
		Switch should be manageable through CLI, Web Interface, SSHv2 and HTTP/HTTPS			
		Switch should support the IEEE 802.3az standard for Energy Efficient Ethernet (EEE) functionality, reducing power consumption of copper ports during periods of low link utilization			
		Switch should support REST APIs or equivalent for programmability			

	Security Features	Switch should support IPv4/v6 Access control lists (ACLs) with minimum 1000 ACL Entries.			
		The switch should support 802.1x Authentication and MAC Authentication Bypass for clients which do not support 802.1x			
		Switch should have integrated module or equivalent technology for platform integrity check and to ensure the boot process is from trusted source			
		Common Criteria Certified (EAL/NDPP) from Day 1 (Proof shall be submitted)			
		The switch should support Web Authentication for Guest users and URL Redirect to redirect all the http access to predefined URL.			
		Switch should support Multiple VLAN Registration Protocol (MVRP) or equivalent			
		The switch should support Downloadable ACLs– These ACLs (access policies) are not defined on the switch, they are downloaded from Policy engine during authentication and applied on the switch.			
		The switch should support Change of Authorization – Any change in access policy can be pushed to all the clients dynamically from NAC server, the clients need not re-authenticate to get the new access policies.			
	HA	Switches must support switch virtualization/stacking feature to extend the control plane across multiple (minimum 8) active switches forming a single virtual switching fabric. Any modules/cables required for the same shall be provided from Day 1			
		Proposed Core, Distribution, access switches and transceivers should from same OEM for interoperability and management.			

	Allied Accessories	To be supplied along with all allied accessories (like power supplies, rack mounting kits, power cords, connectors, cables, licenses, etc) as per project and site requirements for the full operations of the device in line with the requirements enumerated herein, even if details are not indicated under Section-III (BoQ/BoM)			
	Warranty - 24X7	Switch should be provided with hardware replacement warranty and ongoing software upgrades for all major and minor releases for a period of Total 3 years.			
	Additional Support / Warranty	Additional 4 years warranty / support pack			
20	Transceivers				
	10G transceiver	10G SFP+ transceiver, LC LR 10km SMF			
	40G transceiver	40G QSFP+ LC LR4 SM Transceiver			
21	NAC				
	Secure Network Access Control Hardware	Modern IT Licensing Access for 100 Concurrent Endpoints. Hardware/VM based NAC gateway in high availability configuration. Required hardware to be provided in case of VM. Solution shall support role-based network access enforcement for multi-vendor Wi-Fi, wired and VPN networks.			
		Solution should support third-party integration providing customizable workflows using rest-based API's for delivering streamlined registration and payment system integration			
		Solution should support Performing advanced endpoint posture assessments to ensure organization's compliance is met before devices connect (device OS support including Microsoft Windows 7, Apple macOS , Linux - Ubuntu , Linux - RHEL, and Linux - CentOS) for security posture checking with additional license for future use			

		<p>Solution shall support automatic detection and categorization of endpoints for security and audit demands, regardless of device type, using contextual data and use this data for optimizing access policies.</p> <p>Integrated TACACS+ server support for secure authentication of device administrators, operators etc. with varied privilege levels. It should keep a track of the changes made by the logged-in user.</p> <p>Shall provide Self-service device onboarding with built-in certificate authority (CA) for bring your own device (BYOD) from day 1</p> <p>The proposed NAC solution shall be recognized as one of the leaders in network access control (NAC).</p>			
	Warranty - 24x7	NAC should be provided with software upgrades for all major and minor releases for a period of Total 3 years.			
	Additional Support / Warranty	Additional 4 years warranty / support pack			
22	NAC VM/User License - This will be proposed by OEM (If required for their product) NAC VM has to be confirmed in HA. Perpetual license				
	Warranty - 24x7	NAC should be provided with software upgrades for all major and minor releases for a period of Total 3 years.			
	Additional Support / Warranty	Additional 4 years warranty / support pack			
23	NMS				

	Network Management System (NMS)	<ul style="list-style-type: none"> • Shall support WLAN, wired LAN, and VPN devices • Shall support Zero touch provisioning • User and application visibility • Wi-Fi connectivity health analytics • Physical/virtual appliance options. Required hardware to be provided in case of virtual appliance • Shall support scalability of managed devices up to 1,000, required licenses for the proposed quantities of wired and wireless devices should be proposed from day 1. • System should provide client troubleshooting information including Association time, Authentication success/failure and time, DHCP time and DNS time. 			
	Warranty 24/7	NMS should be provided with software upgrades for all major and minor releases for a period of Total 3 years.			
		Day One Device License which has to be proposed			
	Additional Support / Warranty	Additional 4 years warranty / support pack			
24	Point to Point/outdoor Wi-Fi Connection				
	RADIO DEVICE FOR P2P ENVIRNOMENT				
	Frequency	5.150 to 5.950 GHz			
	Band Support	Radio Must support 5.8GHz			
	NLOS ,nLOS operation	Radio Must support NLOS, nLOS condition with iOFDM			
	Throughput	System should support maximum of 1.36 Gbps aggregate throughput			
	Channel Bandwidth	Radio must support 2 channels, each channel with 20, 40, and 80 MHz			
	Spectral Efficiency	Should support more than 8 bps/Hz			
	Channel Selection	Fixed frequency or Dynamic Spectrum Optimization			
		Automatic selection on start-up			
		Continual Self-optimization to avoid interference			

	Max Output Power at Antenna port	Should support maximum 27 dBm, can vary with modulation and settings			
	Modulation	MCS 0 to MCS 9 (BPSK to 256 QAM)			
	Duplex Scheme	Time Division Duplex (TDD) Multiple transmit/receive duty cycles Split frequency operation allows separate transmit and receive frequencies where allowed by regulation.			
	Channel Bonding	System should support channel bonding			
	Sensitivity	-90 dBm			
	Distance Coverage	10 TO 15KMs			
	VLAN Support	VLAN support based on IEEE 802.1Q			
	Security	AES 128 Encryption			
		Identity-Based user account			
		Configurable password rules			
		User Authentication and Radius Support			
	Bandwidth	System should be able to configure symmetric & asymmetric bandwidth. Upload and download percentage should be user configurable.			
	MIMO	Physical Layer 2X 2x2 MIMO			
	Interfaces	Should have 1 Gigabit Ethernet and 1 SFP port			
	IPv6 support	System must support IPv6/IPv4 Dual stack support			
	Asymmetric non-adjacent channel Bonding	System should provide the flexibility for different band to configure different TX and RX frequency for master and slave radio			
	Spectrum analyser mode	Built in Online Spectrum analyser. Running spectrum should not affect the link performance			
	Support for Dynamic Channel Selection	System should support Dynamic Channel Selection to deliver the hitless performance. There must not be any outage in case of Spectrum analyser run			
	INSTALLATION	Built-in e-alignment using GUI on Radio to assist in installation			

	Management	IPv6/IPv4 dual-stack management support SNMPv2 and SNMPv3, HTTPS			
	Quality of Service	Should support as per 802.1p / DiffServ			
	ARQ	System should have the support of ARQ			
	Ethernet Latency	Latency should be below 10ms with 90% Load condition			
	Antenna Type	External Dual Polarized Antenna support of desired gain			
	GPS synchronization	System should support GPS synchronization technique to eliminate mutual interference			
	Operation Temp.	40°C to 60°C Outdoor			
	Wind survival	Minimum 200 km/h			
	Protection	IP66 and IP67			
	Certificates	FCC Part 15E ; RSS 247 Issue 2; EN 302 502; EN 301 893			
		Safety: UL60950-1/22; IEC60950-1/22; EN60950-1.22; CSA-C22.2 No. 60950-1/22			
		EMC: US Part 15B, Canada RSS-GEN, Europe – EN 301 489-1 and -17			
	Gigabit Surge Suppressor	Gigabit Surge Suppressor (56V), 10/100/1000 BaseT			
	Connected Accessories	Supply & Installation of Outdoor Cat 6 Cable, 1Mtrs Patch Cord, Electrical Items (MCB, Sockets, Back box, Flex) with HDPE Pipe 32/42mm required for power connectivity from nearest location.			
	Fabricated Materials as per the site conditions	Concrete basement & Foundation as per Site Condition.			
	Specification for Triangular Tower.				
	Tower Type	Triangular Hot Dip Galvanized (HDG)			
	Height	As per the actual site conditions			
	Base Pate	Required			
	Extension Arms	For Mounting Antenna & Radio Modem.			
	Lighting Arrestors	Required			
	Grounding Earth & etc.	Required			

	Foundation	Civil Work with excavation for Foundation with necessary Concreting & erecting of Tower.			
	Tower Drawing	Tower required to site condition to be designed and Detail Diagram has to be submitted as per site requirements for approval from the NMPA before commencement of work			
	Tower Erection	As per the site location provided and towers base foundation to be designed to sustain wind speed of minimum 200 KMPH.			
25	Spare Stock				
	Edge Switch	48 port Edge Switch			
	Edge Switch	24 port Edge Switch			
	SFP Module	10G SFP+ transceiver, LC LR 10km SMF			

Active Directory - AD

26	AD Server				
	Server - Primary Domain, Secondary Domain, DNS Server	<p>Processor: 2.2GHz/8core/11MB/85W)X2 Nos RAM Memory 64 GB DDR4 expandable, Network controller- 1GB 33 li Ethernet adapter 4 ports. Embedded storage controller – 14-port S100i(SATA only-Support RAID 0/1/5/10) NOTE: Hard Drive 300GB X 4 SAS 12G Enterprise 10K SFF(2.5in) SC 3 Year warranty digitally signed firmware HDD. Provision shall be made for RAID 1 as well.</p> <p>Four USB3.0 back, and two USB 3.0 front, LAN Cards: 2 Nos 1 Gbps and 2 Nos 10Gbps Gigabit Ethernet , 2 nos of 10Gbps SFP, Keyboard and Mouse, USB type Min 64 GB and extendable upto 128GB, Graphics Video Controller with 8Mb SD RAM video memory. Internal storage- 8 SFF- SDD bays Power Supply - (1) 500W Hot Plug Power Supply X 2 Nos. Fans - 5 Hot-plug standard dual rotor redundant fans Form Factor - Rack (1U) Rack Mount Kit: 1U Gen10 SFF Easy Install Rail Kit Management iLO Management Engine (standard) & Control Standard. Ensure at least 30% of usable storage shall be of SDD, 9.5mm sata DVD RW optical drive. NOTE: Warranty - Server Warranty includes 3-Year Parts, 3-Year Labor, 3-Year Onsite support with next business day response</p>			

	Warranty - 24X7 WITH 6 CTR	Servers should be provided with hardware replacement warranty and ongoing software upgrades for all major and minor releases for a period of Total 3 years.			
	Additional Support / Warranty	Additional 4 years warranty / support pack			
STORAGE					
27	Data Storage				
	Storage	25 TB raw, 16 TB useable, expandable to 31.5 TB useable, Gb Ethernet 4 ports standard, 10GbE SFP, 10GbE,			
	DLP	DLP and Antivirus for Storage Vault so as to protect the system against all kinds of cyber threats/malwares/viruses.			
UPS					
28	UPS				
	15KVA ON LINE UPS	15KVA ON LINE UPS: Parallel Operation up to 4 units(60KVA), Input Voltage with range 190V to 478 V, Output Voltage is 220/230 VAC, with AC-AC Efficiency up to 94%, THDi is less than 5%, Overload Capacity is 110%-5 min, 130% 1 min, 150% 10 sec, operating Temperature 0-45 Deg C, LCD + LED Display, Voltage Regulation is +/-1%, Build in Solid State three stage recharge with temperature Compensation, Crest Factor is 3:1, 3 hours battery backup on full load-UPS with external SMF battery only, Battery: 12V, 42 Ah or higher, 3 years warranty for UPS & Battery.			
	1KVA ON LINE UPS	1KVA ON LINE UPS , Input Voltage with range 160V to 300 V, Output Voltage is 220/230 VAC, Output Power factor-Unity, with AC-AC Efficiency up to 92%, THDi is less than 5%, Overload Capacity is 105%-Continuous , 106-120%-30 sec, 121-135% for 10 sec, operating Temperature 0-40 Deg C, LCD+ LED Display, Voltage Regulation is +/-1%, Crest Factor is 3:1, 30 Minute battery backup on full load-UPS with SMF battery only, 3 years warranty for UPS & Battery			

	2KVA ON LINE UPS	2KVA ON LINE UPS: Input Voltage with range 160V to 300 V, Output Voltage is 220/230 VAC, Output Power factor:- Unity, with AC-AC Efficiency up to 92%, THDi is less than 5%, Frequency Range-44Hz to 66Hz, Overload Capacity is 105%-Continuous, 106-120%-30 sec, 121-135% for 10 sec, operating Temperature 0-40 Deg C, LCD+ LED Display, Voltage Regulation is +/-1%, Crest Factor is 3:1, 1 hour battery backup on full load-UPS with external SMF battery only, Battery: 12V, 28 Ah or higher, 3 years warranty for UPS & Battery.			
--	------------------------	--	--	--	--

5.8 Maintenance Support Services during the contract period.

- 5.8.1 The bidder shall provide Comprehensive Maintenance support and man power Support Services for Seven years from the date of Commissioning/Go-live. The bidder shall provide 3 years Warranty/ DLP and 4 years Comprehensive maintenance support for the entire Project.
- 5.8.2 The bidder shall deploy man power resources as per the requirements of the Tender (Pls refer BoQ), after the scrutiny and interview by the Employer. The resident engineers shall be available on working days from 9AM to 6PM. In the event of service required after above hour or on holidays the firm should be prepared to provide service with no extra charges. The bidder shall ensure at the one of the Engineer stays in the Port premises so as to address the network issues beyond the office hours or Pandemic if any. In case of any disaster/an unforeseen situation the firm may be asked to deputy others from their organization to sort out the problems. The engineers so deputed must have their own vehicles, mobile phones and necessary tools like cable tester, crimping/punching machines etc. The man power shall be deployed only after security vetting through the concerned authority and documents shall be submitted in this regard. The Engineers shall perform Administration of Active components of the Network, Installation of patches and Upgrades, Resolution of network issues raised by the user departments. Prior

approval of the Engineer shall be taken before installing Hardware/Software.

Each complaint must be attended and fixed on same day within working hours. If the component needs time for repairing or replacement then an alternate temporary arrangement must be made by the company where the parts/components have failed/damaged or gone into disuse due to any reason, replacement of those part/ components shall be provided free of cost by the firm within 24 hours of call. Where any items/ part/ components need to be replacement, the same shall be replaced with same make, specification and brand of items/components/part in case of brand/model has become absolute the same shall be replaced with superior quality of the items/parts/ components and must carry at least one year warranty. This office will take no Responsibility towards erratic power problem relating to the electricity boards or any other default situation of the nature beyond its control that may cause the equipment to malfunction. In case of pending/high workload the firm will depute additional engineers to clear the backlog to maintain the uptime of the network the details of resident engineers posted at New Mangalore Port should be provided in advance with duty schedule to the computer section no resident engineer should be relived of duties without prior notice of at least one week to in-charge of computer section. No resident Engineer will leave or avail leave till the reliever report for duty.

5.8.3 The resident engineer should carry and display the identity card with photograph provide by the vendor no resident engineer will be allowed to enter the New Mangalore Port sites without proper identity cards as above, they shall report to duty with uniforms.

5.8.4 A register will be maintained by the resident engineer of the firm for booking the components and to keep record of the uptime of the system if possible use of software for this purpose will be preferred and this software will be provided by the firm a Complaint /call register will be maintained by the vendor.

5.9 In case an equipment/machines is being taken for servicing to service Centre the firm will be provided a stand by equipment and will take prior

- permission of the in-charge before taking the equipment out. Cost of transportation and insurance of equipment will be borne by the firm.
- 5.10 The firm shall be maintain all the machines satisfactorily till the end of the AMC tenure and handover all inventory in good working condition to the next vendor in case of AMC is not extended or terminated.
 - 5.11 The selected firm will not involve third party in implementation of service under this AMC
 - 5.12 The vender has always maintain at least following part as standby during the CMC period. Media converter (1) 8-port switches (1) 16-port switches (1), 24-port switches (1), 1 Mt. patch cords (5), 3 Mt patch cord (4), ST-SCOFc patch cord (2), one bundle UTP cable, RJ-45 connectors (20) I/O (5), I for RJ connection (10) etc. a room would be provided to the engineer to stock the above inventory & repairing of equipments.
 - 5.13 The tender will submit a monthly report to the Sr. Dy. Director (EDP), stating the complete list and status of well-being of the network system falling which the bill will not be considered for processing. The tenderer has to attend the quarterly review meeting called by the Sr. Dy. Director (EDP).
 - 5.14 Maintenance is comprehensive nature this include maintenance/repair /replacement of existing fiber cables/ switches/media converter /UTP/ fiber patch cord/UTP patch cord, Active/Passive components etc. with same or equivalent brand throughout the campus.
 - 5.15 The bidder has to give the complete network audit report and complete list of nodes on LAN with hardware address, users, location etc. and to provide the same to In-charge Computer section within the 1st month of the contract.
 - 5.16 The firm has to ensure uninterrupted connectivity of LAN in all Divisions till end users. It includes installations and OFC / UTP segment from the time to time to check proper connectivity, crimping of connectors, configuring and assigning of IP address for all nodes under the Campus network.
 - 5.17 Service Engineer should look after the network administration, Routers, NAC, AD, UPS (both software and hardware based) leased lines.
 - 5.18 Service Engineer has to perform Band width Analysis, Network Traffic Analysis, IT Security vulnerability analysis, Port Scanning, Security threat

analysis, Patch management, Identify and resolve LAN/ Internet faults, monitor and maintain the logs, Bandwidth analysis, Network Traffic /Internet Traffic Analysis, analysis of cyber-attack packets (UDP,TCP, ICMP ,IGMP),spams, Intrusion analysis etc.

- 5.19 Create and Monitor Virtual LANs, Working domains for effective use of network services.
- 5.20 Technical support in video conferencing as and when required.
- 5.21 Control access to and from the New Mangalore Port Authority; intrusion detection with logging; should protect against external intrusions, hacking, denial of Services, port scanning and spoofing attacks;
- 5.22 They have to ascertain network connectivity, data transaction in all nodes connected in the LAN.
- 5.23 Support and administration of VPN connectivity (IP Sec, SSL).
- 5.24 Support for Video conferencing: IP Connectivity testing with other Ports/Ministry, Interaction with service providers, Ports, NIC, BSNL ISPs to address problems related to conferencing and IP connectivity.
- 5.25 Support Service for IPV4 and IPV6, implementation and migration to IPV6
- 5.26 The Engineer shall check the LAN, switches and fiber optical wire other equipment's etc. every month and submit a report to the department. In case of failure to do so a penalty of `1000/- shall be imposed on every default and penalty can be adjusted against pending payment/ EMD/Security Deposit.
- 5.27 All repairs and servicing of equipment shall be carried out on site. In exceptional circumstances where the equipment/component is/are to be taken to the companies premises/service Centre for repair standby component shall be made available. The equipment being taken to the workshop for repair would be at company own risk and expenses.
- 5.28 The replacement of components or equipment shall be as per manufacturer's instruction under orders of IT Division.
- 5.29 Any damage or loss cost to equipment's due to negligence, mishandling shall be made good by contractor either by payment in cash at the prevailing market price of the equipment/items or by replacing equipment/item of same make and specification.

- 5.30 The contractor shall maintain and use genuine/original components for replacement wherever needed.
- 5.31 The operating environment conditions in which the equipment's are presently installed are quite satisfactory. The vendor will not raise any conditions/objections with regard to the working environment for the equipment covered under this AMC would be given on as-is-where-is basis.
- 5.32 The Engineer shall check each LAN Switch (Cleaning of Switches, re-installation of Switches, Jack Panels, Wire Manager & dressing of cables including checking/repairing/replacement of the fiber optical wires.) installed at New Mangalore Port Authority at least once in a month, and get the signatures of the concerned LAN In-Charge and submit the satisfactory reports to this office simultaneously
- 5.33 The vendor will replace the old/breakage wires from LAN point to switch and the wires are in loose condition, it will be installed under the conduit pipe/channel installed in NMPT during AMC period without any extra charges.
- 5.34 The articles of hardware to be supplied by the vendor/tenderer should conform to the standard specifications. It must be of good quality, strength and branded and before installing the hardware, vendor shall take the permission from the office.
- 5.35 Preventive and proactive Maintenance of equipment's, including quarterly cleaning of outer parts / covers with appropriate noncorrosive cleaner and periodical testing of used / idle / standby systems / peripherals.
- 5.36 Diagnostic checkup of the items/equipment's which are under warranty, not under the AMC or otherwise.
- 5.37 Management of Router, Switches, Hubs, NAA, AD, I/O Boxes and cabling.
- 5.38 Ensure complete connectivity of the computers with respective networks. Activity related to trouble shooting of connectivity related problem including Testing and verification related to Network Interface Card (NIC) being bad. Problem related to device drivers of NIC being corrupted Verifying and testing version IP, IRQ and other ID issues related to NIC as and when required. Identifying and trouble-shooting physical (NIC, UTP etc.) connectivity problems at the desktop (user) as well as at the Switches / Router ends i.e. giving point-to-point network connectivity solution, even

crimping. Identifying and troubleshooting of Active/Passive network components, Ensuring print services for network printers.

- 5.39 The Maintenance Contract includes preventive as well as corrective maintenance of all hardware and software components under AMC.
- 5.40 Maintenance shall cover each and every part including plastic body and parts, replacement of any part necessary for keeping the LAN systems active and free from any defects/disturbance; any unscheduled call for corrective and/or preventive maintenance services; taking appropriate measures/steps in time to set right the malfunctioning of the computer system. The replacement of all spares including plastic parts and body is included in the AMC. The replacement of all defective parts with good quality and OEM branded parts will be done by the Service Provider without any extra Used/repaired parts of any other brand from any other source are not acceptable.
- 5.41 In case of need to replace any item/component, the agency shall provide original make genuine parts/components of similar or higher configurations.
- 5.42 The company shall ensure to abide by the copy right, intellectual property rights and other laws as may be applicable for providing any replacements for any malfunctioning the components/items/software under AMC and any violation of any legal requirement by the agency in this regard shall lead to termination of the contract forthwith and forfeiture of security deposit/BG. Besides ensuring compliance to all legal requirements will be the responsibility of the agency, failure to do so would lead to consequences aforesaid and the contractor will keep the Employer indemnified against any liability which may arise on this account.

Letter Comprising the Tender

Ref.

No.....

Date:.....

[To be made in Bidder's Letter Head]

To,

FA&CAO,

New Mangalore Port Authority,

Panambur, Mangalore- 575 010

Karnataka

Sub: Tender for Upgradation of Local Area Network at New Mangalore Port Authority Campus

Dear Sir,

With reference to your bid document dated ¹, we, having examined the bid document and understood its contents, hereby submit our Application for Qualification for the aforesaid Project. The Application is unconditional and unqualified.

1. We acknowledge that the Authority will be relying on the information provided in the Tender and the documents accompanying such Tender of the Bidders for the aforesaid project, and we certify that all information provided in the Tender is true and correct; nothing has been omitted which renders such information misleading; and all documents accompanying such Tender are true copies of their respective originals.

¹All blank spaces shall be suitably filled up by the Applicant to reflect the particulars relating to such Applicant

2. This statement is made for the express purpose of qualifying as a Bidder for the upgradation of the aforesaid Project including repairs and rectifications during the Defects Liability Period as have been specified in the Tender Documents.
3. We shall make available to the Authority any additional information it may find necessary or require to supplement or authenticate the Qualification statement.
4. We acknowledge the right of the Authority to reject our Tender without assigning any reason or otherwise and hereby waive, to the fullest extent permitted by applicable law, our right to challenge the same on any account whatsoever.

5. We certify that in the last 3 (three) years, we/ any of the JV Members or our/ their Associates have neither failed to perform on any contract, as evidenced by imposition of a penalty by an arbitral or judicial authority or a judicial pronouncement or arbitration award, nor been expelled from any project or contract by any public authority nor have had any contract terminated by any public authority for breach on our part.
6. We declare that:
 - (a) We have examined and have no reservations to the bid document, including any Addendum issued by the Authority.
 - (b) We do not have any conflict of interest.
 - (c) We have not directly or indirectly or through an agent engaged or indulged in any corrupt practice, fraudulent practice, coercive practice, undesirable practice or restrictive practice and have submitted necessary Undertakings in the prescribed formats.
 - (d) We hereby certify that we have taken steps to ensure that in conformity with the provisions of the Bid document, no person acting for us or on our behalf has engaged or will engage in any corrupt practice, fraudulent practice, coercive practice, undesirable practice or restrictive practice.
7. We understand that you may cancel the Bidding Process at any time and that you are neither bound to accept any Application that you may receive nor to invite the Bidders to Bid for the Project, without incurring any liability to the Bidders.
8. We believe that we/ our JV/ proposed JV satisfy (ies) the Financial Capacity criteria and meet(s) all the requirements as specified in the Bid document and are qualified to submit a Bid.
9. We declare that we/ any Member of the JV, or our/ its Associates are not a Member of a/ any other JV applying for Bid Proposal.
10. We certify that in regard to matters other than security and integrity of the country, we/ any Member of the JV or any of our/ their Associates have not been convicted by a Court of Law or indicted or adverse orders passed by a regulatory authority which could cast a doubt on our ability to undertake the Project or which relates to a grave offence that outrages the moral sense of the community.
11. We further certify that in regard to matters relating to security and integrity of the country, we/ any Member of the JV or any of our/ their Associates have not been charge-sheeted by any agency of the Government or convicted by a Court of Law.
12. We further certify that no investigation by a regulatory authority is pending either against us/ any Member of the JV or against our/ their Associates or against our CEO or any of our directors/ managers/ employees².

13. We undertake that in case due to any change in facts or circumstances during the Bidding Process, we are attracted by the provisions of disqualification in terms of the provisions of this Bid; we shall intimate the Authority of the same immediately.
14. We hereby irrevocably waive any right or remedy which we may have at any stage at law or howsoever otherwise arising to challenge or question any decision taken by the Authority in connection with the selection of Bidders, selection of the Bidder, or in connection with the selection/ Bidding Process itself, in respect of the above mentioned Project and the terms and implementation thereof.
15. As required by the Tender, we are submitting herewith the following Attachments which shall form part of this Letter:
 - i) Annex-III Details of the Bidder
 - ii) Annex-IV Details of Eligible Projects
 - iii) Annex-V Financial Capacity of the Bidder
 - iv) Annex-VI Statement of Legal Capacity
 - v) Annex-IX Integrity Pact
16. The **Power of Attorney for signing of Tender** and the **Power of Attorney for the Lead Member of JV**, are also attached herewith in the prescribed format.
17. We agree and undertake to abide by all the terms and conditions of the Bid document.
18. {We agree and undertake to be jointly and severally liable for all the obligations of the Contractor under the Contract.}³

*2 In case the Applicant is unable to provide the certification specified in para 13, it may precede the paragraph by the words viz. "Except as specified in Schedule **** hereto". The exceptions to certification or any disclosures relating thereto may be clearly stated in a Schedule to be attached to the Application. The Authority will consider the contents of such Schedule and determine whether or not the exceptions/disclosures are material to the suitability of the Applicant for Bid Proposal hereunder*

IN WITNESS WHEREOF, we submit this Tender under and in accordance with the terms of the Bid documents.

Yours faithfully,

For and on behalf of

.....

(Signature, name and designation of the Authorized Signatory)

³*Omit if the Applicant is not a JV*

Name and seal of the Bidder/ Lead Member

Date:

Place:

Note: Paragraphs in square parenthesis may be omitted, if not applicable, or modified as necessary.

PROFORMA OF IRREVOCABLE BANK GUARANTEE TOWARDS BID BOND(To be submitted on Non-judicial Stamp Paper of `100/-)

Bank Guarantee No.....Dated.....

Amount of Guarantee Rs

Guarantee Cover Period fromto

THIS DEED OF GUARANTEE executed at.....by..... (*Name of Bank*) having its Head/Registered Office at _____ and Branch at (Hereinafter called "**the Bank or the Guarantor**") which expression shall, unless it be repugnant to the subject or context thereof, include its executors, administrators, successors and assigns;

In favor of

The Board of Trustees of New Mangalore Port Authority (hereinafter called "**the Authority**"), having its office at Panambur, Mangalore – 575 010, Karnataka, India, which expression shall, unless it be repugnant to the subject or context thereof, include its executors, administrators, successors and assigns;

WHEREAS M/s... a Company registered under the provisions of (*state the law*) having its registered office and principal place of business at (hereinafter called "**the Bidder**", which expression shall, unless it be repugnant to the subject or context thereof include its executors administrators, successors and assigns) has tendered for Upgradation of Local Area Network at New Mangalore Port Authority Campus (hereinafter called the "**Works**") and

WHEREAS in terms of the Bid document Ref. No.....dated Hereinafter referred to as ("**Bid Document**") the Bidder is required to furnish to the Authority an unconditional and irrevocable Bank

Guarantee for an amount of (Rupees only) as **Bid Bond** and the Guarantor has at the request of the Bidder agreed to provide such Bid Bond in the form of this Bank Guarantee.

NOW THIS DEED WITNESSETH that in consideration of the premises, the Guarantor hereby declares, undertakes and agree as follows:

- a) The Guarantor as primary obligor shall, without demur, pay to the Port Authority an amount not exceeding Rs (Rupees..... only), within 5 (five) days of receipt of a written demand from the Authority stating that the Bid Bond has been forfeited in terms of the Bid Document. Any such demand made on us by the Authority shall be conclusive and absolute as regards the forfeiture of the Bid Bond and the amount due and payable under this Guarantee.
- b) The above payment shall be made by the Guarantor without any reference to the Bidder or any other person and irrespective of whether the claim of the Authority is disputed by the Bidder or not.
- c) This Guarantee shall remain in full force for a period of 180 days from(date)* or for such extended period corresponding to the extension of the validity of the Bid submitted by the Bidder and shall continue to be enforceable until the amount demanded by the Authority under this Guarantee are paid.
- d) In order to give full effect to this Guarantee, the Authority shall be entitled to treat the Guarantor as the principal debtor and the obligations of the Guarantor shall not be affected by any variations in the terms and conditions of the Bid Documents or other documents or by extension of time of performance of any obligations by the Bidder or any postponement for any time of the powers exercisable by the Authority against the Bidder or forebear or enforce any of the terms and conditions relating to

non-compliance of the Bid Document by the Bidder and we shall not be relieved from our obligations by reason of any variation or extension being granted to the Bidder or forbearance or omission on the part of the Authority or any indulgence by the Authority to the Bidder to give such matter or thing whatsoever which under the law relating to sureties would but for this provision have effect of so relieving the Guarantor.

- e) This Guarantee shall be unconditional and irrevocable and shall remain in full force and effect until all our obligations under this Guarantee are duly discharged.
- f) The Guarantor has power to issue this Guarantee and the undersigned is duly authorized to execute this Guarantee pursuant to the powers granted to him or her.

IN WITNESS WHEREOF the Guarantor has set its hands hereunto on the day, month and year first hereinabove written.

Signed and Delivered by the aforesaid
Guarantor) Bank by the hand of the
Authorized Signatory)

Mr./Ms.....[*name*])

.....[*designation*])

Particulars of Bidder

1. (a) Name :

- (b) Country of incorporation :
- (c) Address of the corporate headquarters and its branch office(s), if any, in India:

- (d) Date of incorporation and/or commencement of business :

2. Brief description of the Company including details of its main lines of business and proposed role and responsibilities in this Project:

3. Details of individual(s) who will serve as the point of contact/ communication for the Authority:
 - (a) Name :
 - (b) Designation :
 - (c) Company :
 - (d) Address :
 - (e) Telephone No :
 - (f) (Mobile) :
 - (g) E-Mail Address :
 - (h) Fax Number :

4. Particulars of the Authorized Signatory of the Bidder:
 - (a) Name :
 - (b) Designation :
 - (c) Address :
 - (d) Telephone No :
 - (e) (Mobile) :
 - (f) Fax Number :

5. In case of a Joint Venture:
 - (a) The information above (1-4) should be provided for all the Members of the Joint Venture.

- (b) A copy of the Jt. Bidding Agreement should be attached to the Tender.
- (c) Information regarding the role of each Member should be provided as per table below:

Sr. No.	Name of the Member	Role	Share of work in the Project
1			
2			
3			

- (d) The following information shall also be provided for each Member of the Joint Venture:

Name of Bidder/ member of Joint Venture:

Sl. No.	Criteria	Yes	No
1	Has the Bidder/ constituent of the JV been barred by the [Central/ State] Government, or any entity controlled by it, from participating in any project.		
2	If the answer to 1 is yes, does the bar subsist as on the date of Tender		
3	Has the Bidder/ constituent of the JV paid liquidated damages of more than 5% of the contract value in a contract due to delay or has been penalized due to any other reason in relation to execution of a contract, in the last three years?		

A statement by the Bidder and each of the Members of its Joint Venture(where applicable) or any of their Associates disclosing material non-performance or contractual non-compliance in past projects, contractual disputes and litigation/ arbitration in the recent past is given below (Attach extra sheets, if necessary):

Signature & seal of the Tenderer

- Additional sheets may be used if necessary.
- For Joint Ventured bidders, both Lead Bidder for minimum 30% of Estimate Value & members of JV similar work experience shall be considered for technical qualification.

In case of Joint Ventures, Annexure – 3 shall be furnished separately by each member to the JV from their respective statutory auditors. The same may be consolidated by the lead bidder.

1. Experience for any activity relating to an Eligible Project shall not be claimed twice. In other words, no double counting in respect of the same experience shall be permitted in any manner whatsoever.
2. Certificate in original/ notarized from the employer/ owner must be furnished with the following details:
 - a. Name of the work
 - b. Work order No. and date
 - c. Date of Commencement of work
 - d. Agreement amount
 - e. Date of Completion of work
 - f. Actual Amount Paid
 - g. Scope of works executed
5. The experience certificate of works executed in private sector/ organization, shall be considered for qualification, only on submission of TDS certificate along with work order and completion certificate.
6. It may be noted that in the absence of any detail in the above certificates, the information would be considered inadequate and could lead to exclusion of the relevant project from evaluation.

FINANCIAL TURNOVER

Tenderer should provide financial information as detailed below to demonstrate that they meet the Qualifying requirements for short listing. If required, you may use separate sheets to provide complete financial information.

Summaries of actual assets and liabilities for the Last 03 years.

<u>Financial Year</u>	Turnover		
	2018-19	2019-20	2020-21
LAST THREE FINANCIAL YEARS ENDING 31ST MARCH OF THE PREVIOUS YEAR			

Instructions:

1. The Bidder shall attach copies of the balance sheets, Profit and loss financial statements and Annual Reports for 3 (three) years with UDIN preceding the Tender Due Date. The financial statements shall:
 - a. reflect the financial situation of the Bidder and its Associates where the Bidders relying on its Associate's financials;
 - b. be audited by a statutory auditor;
 - c. be complete, including all notes to the financial statements; and
 - d. Correspond to accounting periods already completed and audited (no statements for partial periods shall be requested or accepted).
2. In the case of a JV, a copy of the Jt. Bidding Agreement shall be submitted in accordance of the Bid document.
3. The Bidder shall also provide the name and address of the Bankers to the Bidder.

Signature & Seal of the Tenderer

Statement of Legal Capacity

(To be forwarded on the letterhead of the Bidder/ Lead Member of Joint Venture)

Ref.

Date:

To,

The FA&CAO
Finance Department,
New Mangalore Port Authority
Panambur, Mangalore 575 010
Karnataka

Dear Sir,

We hereby confirm that we/ our members in the Joint Venture (constitution of which has been described in the Tender) satisfy the terms and conditions laid out in the bid document.

We have agreed that..... (Insert member's name) will act as the Lead Member of our Joint Venture.*

We have agreed that (Insert individual's name) will act as our representative/ will act as the representative of the joint venture on its behalf *and has been duly authorized to submit the Bid. Further, the authorized signatory is vested with requisite powers to furnish such letter and authenticate the same.

Thanking you,

Yours faithfully

for and on behalf of

.....

(Signature, name and designation of the authorized signatory)

** Please strike out whichever is not applicable.*

ANNEXURE -VII

Tenderer shall furnish Bank information for E-Payment

1	Name and Full address of the Tenderer & E-Mail address	
2	Credit Account No.	
3	Account Type (SB or CA or OD)	
4	Name of the Bank	
5	Branch full address with Telephone No.	
6	MICR Code. (Should be 9 digits)	
7	Telephone/Mobile/Fax No. of the Tenderer	
8	PAN (Permanent Account Number)	
9	GST Registration Number with Certificate	
10	TIN No.	
11	Xerox Copy of Cheque and PAN card should be enclosed	

Signature and Seal of the Tenderer

[To be executed on non-judicial stamp paper of `100/- in India to be purchased in the name of the Lead Member of the JV]

Power of Attorney for signing the Tender

Know all men by these presents, We(name of the firm and address of the registered office) do hereby irrevocably constitute, nominate, appoint and authorize Mr/Ms_____ (name), son/daughter/wife of _____ and presently residing at _____, who is presently employed with us/ the Lead Member of our Joint Venture and holding the position of_____, as our true and lawful attorney (hereinafter referred to as the "**Attorney**") to do in our name and on our behalf, all such acts, deeds and things as are necessary or required in connection with or incidental to submission of our Tender for Bid and submission of our bid for the "Upgradation of Local Area Network at New Mangalore Port Authority Campus" Project proposed by New Mangalore Port Authority (the "Authority") including but not limited to signing and submission of all Tenders, bids and other documents and writings, participate in Pre-Tenders and other conferences and providing information/ responses to the Authority, representing us in all matters before the Authority, signing and execution of all contracts including the Concession Agreement and undertakings consequent to acceptance of our bid, and generally dealing with the Authority in all matters in connection with or relating to or arising out of our bid for the said Project and/ or upon award thereof to us and/or till the entering into of the Concession Agreement with the Authority.

AND we hereby agree to ratify and confirm and do hereby ratify and confirm all acts, deeds and things lawfully done or caused to be done by our said Attorney pursuant to and in exercise of the powers conferred by this Power of Attorney and that all acts, deeds and things done by our said Attorney in exercise of the powers hereby conferred shall and shall always be deemed to have been done by us.

IN WITNESS WHERE OF WE, _____, THE ABOVE NAMED
PRINCIPAL
HAVE EXECUTED THIS POWER OF ATTORNEY ON THIS _____DAY OF __,
20_____

Witnesses:

1.

For _____ (Signature, name, designation and address)

2.

(Notarized)

Accepted
(Signature)

(Name, Title and Address of the Attorney)

Notes:

- The mode of execution of the Power of Attorney should be in accordance with the procedure, if any laid down by the applicable law and the charter documents of the executant(s) and when it is so required, the same should be under common seal affixed in accordance with the required procedure.
- Wherever required, the Bidder should submit for verification the extract of the charter documents and documents such as a board or shareholders' resolution/power of attorney in favor of the person executing this Power of Attorney for the delegation of power hereunder on behalf of the Bidder.
- For a Power of Attorney executed and issued overseas, the document will also have to be legalized by the Indian Embassy and notarized in the jurisdiction where the Power of Attorney is being issued. However, the Power of Attorney provided by Bidders from countries that have signed The Hague Legislation Convention, 1961 are not required to be legalized by the Indian Embassy if it carries a conforming Appositille certificate.

[To be executed on non-judicial stamp paper of `100/- in India to be purchased in the name of the Lead Member of the Consortium]

Power of Attorney for Lead Member of Joint Venture

Whereas the New Mangalore Port Authority ("the Authority") has invited Tenders from interested parties for the "Upgradation of Local Area Network at New Mangalore Port Authority Campus".

Whereas,, and

(collectively the "Joint Venture") being Members of the Joint Venture are interested in bidding for the Project in accordance with the terms and conditions of the Bid document and other connected documents in respect of the Project, and

Whereas, it is necessary for the Members of the JV to designate one of them as the Lead Member with all necessary power and authority to do for and on behalf of the Joint Venture, all acts, deeds and things as may be necessary in connection with the JV's bid for the Project and its execution.

NOW, THEREFORE, KNOW ALL MEN BY THESE PRESENTS

We,..... having our registered office at.....,M/s..... having our registered office at....., M/s..... having our registered office at....., and M/s..... Having our registered office at (hereinafter collectively referred to as the "Principals") do hereby irrevocably designate, nominate, constitute, appoint and authorize M/s..... having its registered office at.....,being one of the Members of the joint venture, as the Lead Member and true and lawful attorney of the JV (hereinafter referred to as the "Attorney"). We hereby irrevocably authorize the Attorney (with power to sub-delegate) to conduct all business for and on behalf of the Joint venture and any one of us during the bidding process and, in the event the joint venture is awarded the concession/contract, during the execution of the Project and in this regard, to do on our behalf and on behalf of the joint venture, all or any of such acts, deeds or things as are necessary

or required or incidental to the Bid Proposal of the joint venture and submission of its bid for the Project, including but not limited to signing and submission of all Tenders, bids and other documents and writings, participate in bidders and other conferences, respond to queries, submit information/ documents, sign and execute contracts and undertakings consequent to acceptance of the bid of the joint venture and generally to represent the joint venture in all its dealings with the Authority, and/ or any other Government Agency or any person, in all matters in connection with or relating to or arising out of the JV's bid for the Project and/ or upon award thereof till the Agreement is entered into with the Authority.

AND hereby agree to ratify and confirm and do hereby ratify and confirm all acts, deeds and things done or caused to be done by our said Attorney pursuant to and in exercise of the powers conferred by this Power of Attorney and that all acts, deeds and things done by our said Attorney in exercise of the powers hereby conferred shall and shall always be deemed to have been done by us/ Joint venture.

IN WITNESS WHEREOF WE THE PRINCIPALS ABOVE NAMED HAVE EXECUTED THIS

POWER OF ATTORNEY ON THIS DAY OF , 20

For..... [To be executed by all the Members of Joint venture]

(Signature)
(Name and Title)

For.....

(Signature)
(Name and Title)

For.....

(Signature)
(Name
and Title)

Witnesses:

- 1.
- 2.

Notes:

- The mode of execution of the Power of Attorney should be in accordance with the procedure, if any, laid down by the applicable law and the charter documents of the executant(s) and when it is so required, the same should be under common seal affixed in accordance with the required procedure.
- Also, wherever required, the Bidder should submit for verification the extract of the charter documents and documents such as a board or shareholders' resolution/ power of attorney in favour of the person executing this Power of Attorney for the delegation of power hereunder on behalf of the Bidder.
- For a Power of Attorney executed and issued overseas, the document will also have to be legalised by the Indian Embassy and notarised in the jurisdiction where the Power of Attorney is being issued.

Joint Bidding Agreement

[To be executed on non-judicial stamp paper of `100/- in India to be purchased in the name of the Lead Member of the Joint Venture]

THIS JOINT BIDDING AGREEMENT is entered into on this theday of 2023.

AMONGST

1. {company name} and having its registered office at (hereinafter referred to as the “**First Party**” which expression shall, unless repugnant to the context include its successors and permitted assigns)

AND

2. {company name} and having its registered office at (hereinafter referred to as the “**Second Party**” which expression shall, unless repugnant to the context include its successors and permitted assigns)

AND

3. {Company Name and having its registered office at (hereinafter referred to as the “**Third Party**” which expression shall, unless repugnant to the context include its successors and permitted assigns)}

The above mentioned **First Party, Second Party and Third Party** are collectively referred to as the “**Parties**” and each is individually referred to as a “**Party**”

WHEREAS,

- (A) New Mangalore Port Authority, represented by its FA&CAO and having its offices at Panambur, Mangalore 575 010, Karnataka (hereinafter referred to as the “**Authority**” which expression shall, unless repugnant to the context or meaning thereof, include its administrators, successors and assigns) has invited Tenders (“**Tenders**”) by its Bid document Ref.....dated for Qualification Requirement (QR) and Commercial & Price Bid for Upgradation of Local Area Network at New Mangalore Port Authority Campus.

* Amend as required

- (B) The Parties are interested in jointly bidding for the Project as Parties of a Joint Venture and in accordance with the terms and conditions of the Bid document and other bid documents in respect of the Project, and
- (C) It is a necessary condition under the Bid document that the Members of the Consortium shall enter into a **Joint Bidding Agreement** and furnish a notarised copy thereof with the Tender.

NOW IT IS HEREBY AGREED AS FOLLOWS:

1. Definitions and Interpretations

In this Agreement, the Capitalized Terms shall, unless the context otherwise requires, have the meaning ascribed thereto under the Bid document.

2. Joint Venture

- 2.1. The Parties do hereby irrevocably constitute a Joint Venture ("**Joint Venture**") for the purposes of jointly participating in the Qualification Requirement ("QR") under the Bid Document and, subject to meeting such QR, in the subsequent process of Commercial & Price bidding (collectively "**Bidding Process**") for the Project. This Agreement and the cooperation between the Parties hereunder for this Project shall be deemed to be *exclusive*.
- 2.2. The Parties hereby undertake to participate in the Bidding Process only through this Joint Venture and not individually and/or through any other Joint Venture or any other entity constituted for this Project, either directly or indirectly or through any of their Associates.
- 2.3. Subject to the Joint Venture meeting the QR and it being selected as the successful Bidder in its Commercial & Price bidding for the Project pursuant to the Bid document issued by the Authority, the Parties hereto shall, prior to issue of LoA to the Joint Venture by the Authority, enter into a detailed **Joint Venture Agreement** wherein the roles and responsibilities of each of the Parties shall be clearly defined. Such Agreement shall *inter alia* cover contractual rights, liabilities and obligations of the Parties to the Authority and the Parties *inter se* in line with the Modified General Conditions of the Contract and Conditions of Particular Application to this Project issued by the Authority along with this Bid document. The Parties agree to submit a notarized copy of such Agreement for approval of the Authority and carry out necessary amendments thereto if and when reasonably requested to do so by the Authority. A notarized copy of this Agreement shall be filed with the Authority by the Joint Venture.
- 2.4. Each of the Parties has, through all corporate actions and duly signed by its authorized representative, issued

requisite legally binding Power of Attorney to the Lead Member:

- i) To submit necessary Tender for (i) Qualification Requirement (QR) and (ii) Commercial & Price Bid for the Project in response to the Bid document issued by the Authority;
- ii) In the event the Parties to the Joint Venture are qualified and selected as the successful Bidder for Project pursuant to the said Bid document, to cause all the Parties to sign the Contract for the Project;
- iii) Following conclusion of such Contract, to be responsible to the Authority on behalf of the Parties for timely execution and completion of the Project, to receive payments from the Authority on behalf of the Parties for their respective scope of work and to incur any and all liabilities on their behalf; and
- iv) To submit notarized copies of (i) Power Attorney issued to the Authorized Signatory for signing the Bid as per format given in **Annexure -VIII**, (ii) Power of Attorney issued to the Lead Member of Consortium by all the Members of Consortium as per format given in **Annexure -IX**; and (iii) a copy of this Joint Bidding Agreement as part of Tender to be submitted by the Joint Venture in response to Bid proposal.

3. **Covenants**

- 3.1. One of the Parties to Joint Venture has purchased/downloaded the relevant Bid documents and all the Addendum thereto, obtained necessary clarifications and found them to be adequate for the intended purpose.
- 3.2. The Parties agree to co-operate and support each other and hereby undertake to submit necessary technical, financial and project execution and completion data and documentation and also comply fully with the technical, financial and project execution experience and other requirements as prescribed under the Bid document.
- 3.3. The Parties to this Joint Venture hereby agree to participate in the QR and Commercial & Price Bidding for the Project pursuant to the Bid document issued to the Joint Venture by the Authority.
- 3.4. The Parties hereby confirm that there shall be no change in the structure of this Joint Venture or any substantial change in the shareholding pattern of the Parties constituting this Joint venture without the written consent from the Authority, as the case may be, both during the Bidding against the Bid proposal and hereafter, if qualified and selected as the successful Bidder for the Project, during the entire period of execution and completion of the Project.
- 3.5. None of the Parties hereto shall assign or transfer any of their rights or obligations under this Agreement without the prior written consent of the other Parties and the Authority.

4. **Joint & Several Liability and Indemnity**

- 4.1. The Parties do hereby undertake to be jointly and severally responsible for all the obligations and liabilities relating to the Project in accordance with the terms & conditions of this Bid document and, subject to award of Contract for the Project on the Parties to the joint venture, for successful execution and completion of the Project in terms of the said Contract.
- 4.2. The Parties hereto also undertake and agree that, notwithstanding division and allotment of the scope of work and responsibilities for the Project between the Parties, each of the Parties shall be jointly and severally liable for the performance or non- performance or any and all defaults in the performance of the scope of work of all the other Parties in addition to its own scope of work and responsibility for the Project and shall be liable for satisfactory execution and completion of the entire Contract despite such division and allotment of scope of work and responsibilities.
- 4.3. The Parties hereby agree to jointly and severally indemnify and hold the Authority harmless against any loss, cost and damage which may be incurred or sustained by the Authority as a consequence of any performance, non-performance or any default in the performance of scope of work and responsibilities for the Project by any or all of the Parties hereto.

5. **Roles & Responsibilities of the Parties**

The Parties hereby undertake to perform the roles and responsibilities as described below:

- 5.1. One of the Parties, which has successfully completed minimum 30% from Estimated Value of work at least for one Similar Project, or the Party on whose experience pre-qualification is sought by the Parties pursuant to the Bid document, shall be nominated as Lead Member of the Joint Venture ("**Joint Venture Leader**") and has been authorized by all the Parties to represent them and to act for, receive instructions, incur liabilities, receive payments and discharge obligations on behalf of the Joint Venture.
- 5.2. All communications between the Authority and the Joint Venture shall be addressed to and routed through the **Joint leader** who shall be the sole point of contact between the Authority and the Parties regarding the Bid document both during QR and subsequently during Commercial & Price bidding process under the Bid proposal.
- 5.3. The Joint Venture hereby agree that the lead member shall undertake and perform at least 30 (thirty) percent of the project and above.
- 5.4. The Parties have agreed to establish a Management Committee ("**Committee**") with equal representation from

all the Parties for expeditious and effective management of all the affairs of the Joint Venture.

6. Representations & Warranties.

6.1. Each of the Parties hereto represents and warrants to the other Parties and the Authority, as of the date of this Agreement, that -

- a) Such Party is duly organized, validly existing and in good standing under the laws of its incorporation and has all requisite power and authority to enter into this Agreement;
- b) The execution, delivery and performance by such Party of this Agreement has been authorized by all necessary and appropriate corporate or governmental action and a certified copy of board resolution/power of attorney in favour of the person executing this Agreement for the delegation of power and authority to execute this Agreement on behalf of the Joint Venture of Parties is annexed to this Agreement, and will not, to the best of its knowledge:
 - (i) require any consent or approval not already obtained;
 - (ii) violate any Applicable Law presently in effect and having applicability to it;
 - (iii) violate the Memorandum & Articles of Association, by-laws or other applicable organizational documents thereof;
 - (iv) violate any clearance, permit, concession, grant, license or other governmental authorization, approval, judgement, order or decree or any mortgage agreement, indenture or any other instrument to which such Party is a party or by which such Party or any of its properties or assets are bound or that is otherwise applicable to such Party; or
 - (v) create or impose any liens, mortgages, pledges, claims, security interests, charges or Encumbrances or obligations to create a lien, charge, pledge, security interest, encumbrances or mortgage in or on the property of such Party, except for encumbrances that would not, individually or in the aggregate, have a material adverse effect on the financial condition or prospects or business of such Party so as to prevent such Party from fulfilling its obligations under this Agreement;

- c) This Agreement is the legal and binding obligation of such Party, enforceable in accordance with its terms against it; and
- d) There is no litigation pending or, to the best of such Party's knowledge, threatened to which it or any of its Affiliates is a party that presently affects or which would have a material adverse effect on the financial condition or prospects or business of such Party in the fulfilment of its obligations under this Agreement.

7. **Term & Termination**

7.1. This Agreement shall be effective from the date hereof and shall continue in full force and effect until the earlier of the following events –

- i) The Parties' Tender for QR and Commercial & Price Bid against the Bid document has not been successful; or
- ii) Upon meeting the QR of the Parties, the Commercial & Price Bid by the Parties has not been successful and the LoA and Contract for the Project has been awarded to another party, or
- iii) Upon issue of LoA and award of the Contract for the Project, the Project has been successfully executed and completed by the Parties or the Contract for the Project has been terminated; all payments due under the Contract have been received and liabilities between the Parties *inter se*, the Authority and third parties have been satisfactorily discharged or waived.
- iv) The Parties agree to terminate this Agreement with the prior written approval of the Authority

7.2. However, notwithstanding any such termination, the obligations already incurred by any of the Parties prior to such termination and those other obligations, which by their very nature are meant to continue, shall survive any such termination.

8. **Miscellaneous**

8.1. This Agreement shall be governed by laws of India.

8.2. The Parties acknowledge and accept that this Agreement shall not be amended by the Parties without the prior written consent of the Authority.

IN WITNESS WHEREOF THE PARTIES ABOVE NAMED HAVE EXECUTED AND DELIVERED THIS AGREEMENT AS OF THE DATE, MONTH AND YEAR FIRST ABOVE WRITTEN.

SIGNED, SEALED AND DELIVERED

(1) *for and on behalf of* FIRST PARTY or LEAD MEMBER WITNESSES:

By _____

Name:

Title:

(2) *for and on behalf of* SECOND PARTY by:

1. _____

By: _____ 2. _____

Name:

Title:

(3) *for and on behalf of* THIRD PARTY by:

By: _____ 1. _____

Name:

Title:

Notes:

1. ***In respect of a Power of Attorney executed and issue in India, it shall be accompanied by a copy of the Board Resolution to issue of such power of attorney in favour of the person executing this Agreement, for the delegation of power and authority to execute this Agreement on behalf of the Party to the Joint Venture***
2. ***In respect of a Power of Attorney executed and issued overseas, it shall be legalised by the Indian Embassy and notarised in the jurisdiction where the Power of Attorney has been executed and issued.***

PROFORMA OF INTEGRITY PACT

[to be made in Bidder's Letter head]

General

This pre-bid pre-contract Agreement (hereinafter called the Integrity Pact) is made on _____day of the month of__2023, between, on one hand, the Board of Trustees of New Mangalore Port Authority acting through Shri. _____, (Designation of the Officer), New Mangalore Port Authority (hereinafter called the 'AUTHORITY', which expression shall mean and include, unless the context otherwise requires, his successors in office and assigns) of the First Part and M/s. _____ represented by Shri. _____ Chief Executive Officer (hereinafter called the "BIDDER" which expression shall mean and include, unless the context otherwise requires, his successors and permitted assigns) of the Second Part.

WHEREAS the 'AUTHORITY' has invited bids for the project of **“Upgradation of Local Area Network at New Mangalore Port Authority Campus” hereinafter referred to as the “Project”**) and the BIDDER is submitting his bid for the project and WHEREAS the BIDDER is a Private Limited company/Public Limited company/Government undertaking/registered partnership firm/ constituted in accordance with the relevant law in the matter and the 'AUTHORITY' is New Mangalore Port Authority.

NOW, THEREFORE,

To avoid all forms of corruption by following a system that is fair, transparent and free from any influence/prejudiced dealings prior to, during and subsequent to the currency of the contract to be entered into with a view to:-

Enabling BIDDERS to abstain from bribing or indulging in any corrupt practice in order to secure the contract by providing assurance to them that their competitors will also abstain from bribing and other corrupt practices and the 'AUTHORITY' will commit to prevent corruption, in any form, by its officials by following transparent procedures.

The parties hereto hereby agree to enter into this Integrity Pact and agree as follows:

1. Commitments of the 'AUTHORITY'

- 1.1 The 'AUTHORITY' undertakes that no official of the 'AUTHORITY', connected directly or indirectly with the contract, will demand, take a promise for or accept, directly or through intermediaries, any bribe, consideration, gift, reward, favour or any material or immaterial benefit or any other advantage from the BIDDER, either for themselves or for any person, organization or third party related

- to the contract in exchange for an advantage in the bidding process, bid evaluation, contracting or implementation process related to the contract.
- 1.2 The 'AUTHORITY' will, during the pre-contract stage, treat all BIDDERS alike and will provide to all BIDDERS the same information and will not provide any such information to any particular BIDDER which could afford an advantage to that particular BIDDER in comparison to other BIDDERS
 - 1.3 All the officials of the 'AUTHORITY' will report to the appropriate Government office any attempted or completed breaches of the above commitments as well as any substantial suspicion of such a breach.
2. In case any such preceding misconduct on the part of such official(s) is reported by the BIDDER to the 'AUTHORITY' with full and verifiable facts and the same is prima facie found to be correct by the 'AUTHORITY' necessary disciplinary proceedings, or any other action as deemed fit, including criminal proceedings may be initiated by the 'AUTHORITY' and such a person shall be debarred from further dealings related-to the contract process. In such a case while an enquiry is being conducted by the 'AUTHORITY' the proceedings under the contract would not be stalled.
 3. **Commitments of BIDDERS** The BIDDER commits itself to take all measures necessary to prevent corrupt practices, unfair means and illegal activities during any stage of its bid or during any pre-contract or post-contract stage in order to secure the contract or in furtherance to secure it and in particular commit itself to the following:-
 - 3.1 The BIDDER will not offer, directly or through intermediaries, any bribe, gift, consideration, reward, favour, any material or immaterial benefit or other advantage, commission, fees, brokerage or inducement to any official of the 'AUTHORITY' connected directly or indirectly with the bidding process, or to any person, organization or third party related to the contract in exchange for any advantage in the bidding, evaluation, contracting and implementation of the contract.
 - 3.2 The BIDDER further undertakes that it has not given, offered or promised to give, directly or indirectly any bribe, gift, consideration, reward, favour, any material or immaterial benefit or other advantage, commission, fees, brokerage or inducement to any official of the 'AUTHORITY' or otherwise in procuring the Contract or forbearing to do or having done any act in relation to the obtaining or execution of the contract or any other contract with the Government for showing or forbearing to show favour or disfavour to any person in relation to the contract or any other contract with the Government.
 - 3.3 * BIDDERS shall disclose the name and address of agents and representatives and Indian BIDDERS shall disclose their foreign principals or associates.
 - 3.4 * BIDDERS shall disclose the payments to be made by them to agents/brokers or any other intermediary, in connection with this bid/contract.

- 3.5 * The BIDDER further confirms and declares to the 'AUTHORITY' that the BIDDER has not engaged any individual or firm or company whether Indian or foreign to intercede, facilitate or in any way to recommend to the AUTHORITY or any of its functionaries, whether officially or unofficially to the award of the contract to the BIDDER, nor has any amount been paid, promised or intended to be paid to any such individual, firm or company in respect of any such intercession, facilitation or recommendation.
- 3.6 The BIDDER, either while presenting the bid or during pre-contract negotiations or before signing the contract, shall disclose any payments he has made, is committed to or intends to make to officials of the 'AUTHORITY' or their family members, agents, brokers or any other intermediaries in connection with the contract and the details of services agreed upon for such payments.
- 3.7 The BIDDER will not collude with other parties interested in the contract to impair the transparency, fairness and progress of the bidding process, bid evaluation, contracting and implementation of the contract.
- 3.8 The BIDDER will not accept any advantage in exchange for any corrupt practice, unfair means and illegal activities.
- 3.9 The BIDDER shall not use improperly, for purposes of competition or personal gain, or pass on to others, any information provided by the 'AUTHORITY' as part of the business relationship, regarding plans, technical proposals and business details, including information contained in any electronic data carrier. The BIDDER also undertakes to exercise due and adequate care lest any such information is divulged.
- 3.10 The BIDDER commits to refrain from giving any complaint directly or through any other manner without supporting it with full and verifiable facts.
- 3.11 The BIDDER shall not instigate or cause to instigate any third person to commit any of the actions mentioned above.
- 3.12 If the BIDDER or any employee of the BIDDER or any person acting on behalf of the BIDDER, either directly or indirectly, is a relative of any of the officers of the 'AUTHORITY' or alternatively, if any relative of an officer of the 'AUTHORITY' has financial interest/stake in the bidder's firm, the same shall be disclosed by the BIDDER at the time of filing of tender. The term 'relative' for this purpose would be as defined in Section 6 of the Companies Act 1956.
- 3.13 The BIDDER shall not lend to or borrow any money from or enter into any monetary dealings or transactions, directly or indirectly, with any employee of the 'AUTHORITY'.

4. **Previous Transgression**

- 4.1 The BIDDER declares that no previous transgression occurred in the last three years immediately before signing of this Integrity Pact, with any other company in any country in respect of any corrupt practices envisaged hereunder or with any Public Sector

Enterprise in India or any Government Department in India that could justify bidder's exclusion from the tender process.

- 4.2 The BIDDER agrees that if it makes incorrect statement on this subject, BIDDER can be disqualified from the tender process or the contract, if already awarded, can be terminated for such reason.

5 **Earnest Money/ Security Deposit**

- 5.1 While submitting commercial bid, the BIDDER shall deposit an amount **`20,79,668/- (Rupees Twenty Lakhs Seventy Nine Thousand Six Hundred and Sixty Eight only)** as **Bid Bond in the form of a Bank Guarantee**, in favour of the Authority by a nationalized Bank/Branch at Mangalore as per the format given in Tender Document.
- 5.2 The Bid Bond shall be valid up to a period of 180 days from the Bid Due Date.
- 5.3 In case of the successful BIDDER, a Performance Security in the form of Bank Guarantee valid till 30 days after the end of defect liability period will also be furnished to the 'AUTHORITY' within 15 days of Letter of Acceptance of the Bid by the 'AUTHORITY'.
- 5.4 In case of the successful BIDDER, a clause would also be incorporated in the Article pertaining to Performance Security in the Project Contract that the provisions of Sanctions for Violation shall be applicable for forfeiture of Performance Security in case of a decision by the AUTHORITY to forfeit the same without assigning any reason for imposing sanction for violation of this Pact.
- 5.5 No interest shall be payable by the 'AUTHORITY' to the BIDDER on Earnest Money/Security Deposit for the period of its currency.

6 **Sanctions for Violations**

- 6.1 Any breach of the aforesaid provisions by the BIDDER or any one employed by it or acting on its behalf (whether with or without the knowledge of the BIDDER) shall entitle the 'AUTHORITY' to take all or any one of the following actions, wherever required:-
- (i) To immediately call off the pre contract negotiations without assigning any reason or giving any compensation to the BIDDER. However, the proceedings with the other BIDDER(s) would continue.
 - (ii) The Earnest Money Deposit (in pre-contract stage) and/or Security Deposit/Performance Bond (after the contract is signed) shall stand forfeited either fully or partially, as decided by the 'AUTHORITY' and the 'AUTHORITY' shall not be required to assign any reason therefore.
 - (iii) To immediately cancel the contract, if already signed, without giving any compensation to the BIDDER.
 - (iv) To cancel all or any other Contracts with the BIDDER. The BIDDER shall, be liable to pay compensation for any loss or damage to the 'AUTHORITY' resulting from such cancellation/rescission and the 'AUTHORITY' shall be

entitled to deduct the amount so payable from the money(s) due to the BIDDER.

- (v) To debar the BIDDER from participating in future bidding processes of the Government of India for a minimum period of five years, which may be further extended at the discretion of the 'AUTHORITY'
- (vi) To recover all sums paid in violation of this Pact by BIDDER(s) to any middleman or agent or broker with a view to securing the contract.
- (vii) Forfeiture of Performance Security in case of a decision by the 'AUTHORITY' to forfeit the same without assigning any reason for imposing sanction for violation of this Pact.

6.2 The 'AUTHORITY' will be entitled to take all or any of the actions mentioned at para 6.1(i) to (vii) of this Pact also on the Commission by the BIDDER or any one employed by it or acting on its behalf (whether with or without the knowledge of the BIDDER), of an offence as defined in Chapter IX of the Indian Penal code, 1860 or Prevention of Corruption Act, 1988 or any other statute enacted for prevention of corruption.

6.3 The decision of the 'AUTHORITY' to the effect that a breach of the provisions of this Pact has been committed by the BIDDER shall be final and conclusive on the BIDDER. However, the BIDDER can approach the Independent Monitor(s) appointed for the purposes of this Pact.

7 Fall Clause

7.1 The BIDDER undertakes that it has not performed/is not performing similar project at a price lower than that offered in the present bid in respect of any other Ministry/Department of the Government of India or PSU and if it is found at any stage that similar project was performed by the BIDDER to any other Ministry/Department of the Government of India or a PSU at a lower price, then that very price, with due allowance for elapsed time, will be applicable to the present case and the difference in the cost would be refunded by the BIDDER to the 'AUTHORITY', if the contract has already been concluded.

8 Independent Monitors

8.1 The 'AUTHORITY' has appointed the following Independent Monitors (hereinafter referred to as Monitors) for this Pact in consultation with the Central Vigilance Commission.

Shri Prem Chand Pankaj,
Ex CMD, NEEPCO,
M 402, Pioneer Park,
Sector 61, Golf Course,
Extn., Road, Gurgaon,
Mob: No. 9717433886
Email ID: prempankaj@gmail.com

- 8.2 The task of the Monitors shall be to review independently and objectively, whether and to what extent the parties comply with the obligations under this Pact.
- 8.3 The Monitors shall not be subject to instructions by the representatives of the parties and perform their functions neutrally and independently.
- 8.4 Both the parties accept that the Monitors have the right to access all the documents relating to the project/bidding, including minutes of meetings.
- 8.5 As soon as the Monitor notices, or has reason to believe, a violation of this Pact, he will so inform the Authority designated by the AUTHORITY,
- 8.6 The BIDDER(s) accepts that the Monitor has the right to access without restriction to all Project documentation of the AUTHORITY, including that provided by the BIDDER. The BIDDER will also grant the Monitor, upon his request and demonstration of a valid interest, unrestricted and unconditional access to his project documentation. The same is applicable to Subcontractors. The Monitor shall be under contractual obligation to treat the information and documents of the BIDDER/Subcontractor(s) with confidentiality.
- 8.7 The AUTHORITY, will provide to the Monitor sufficient information about all meetings among the parties related to the Project provided such meetings could have an impact on the contractual relations between the parties. The parties will offer to the Monitor the option to participate in such meetings.
- 8.8 The Monitor will submit a written report to the designated Authority within 8 to 10 weeks from the date of reference or intimation to him by the AUTHORITY/ BIDDER and, should the occasion arise, submit proposals for correcting problematic situations.

9 **Facilitation of Investigation :**

In case of any allegation of violation of any provisions of this pact or payment of commission, the AUTHORITY or its agencies shall be entitled to examine all the documents including the Books of Accounts of the BIDDER and the BIDDER shall provide necessary information and documents in English and shall extend all possible help for the purpose of such examination.

10 **Law and Place of Jurisdiction :**

This Pact is subject to Indian Law.' The place of performance and jurisdiction is the seat of the AUTHORITY

11 **Other Legal Actions:**

The actions stipulated in this Integrity Pact are without prejudice to any other legal action that may follow in accordance with the provisions of the extant law in force relating to any civil or criminal proceedings.

12 Validity

12.1 The validity of this Integrity Pact shall be from date of its signing and extend upto 5 years or the complete execution of the contract to the satisfaction of both the AUTHORITY and the BIDDER, including warranty period, whichever is later. In case BIDDER is unsuccessful, this Integrity Pact shall expire after six months from the date of the signing of the contract.

12.2 Should one or several provisions of this Pact turn out to be invalid; the remainder of this Pact shall remain valid. In this case, the parties will strive to come to an agreement to their original intentions.

13 The parties hereby sign this Integrity Pact at _____ on _____

AUTHORITY

BIDDER

Name of the Officer

CHIEF EXECUTIVE

OFFICER Designation

Dept./MINISTRY/PSU

Witness

Witness

1. _____

1. _____

2. _____

2. _____

* Provisions of these clauses would need to be amended/ deleted in line with the policy of the AUTHORITY in regard to involvement of Indian agents of foreign bidders.

DETAILS OF ONGOING CONTRACTS AT NMPA

Sl No	Work Order Description	Work Order No. & date	Work Order Value	Department which has issued the Work order	Date of completion as per work order

Sign & Seal of the Contractor

VERIFICATION OF LOCAL CONTENT

Tender No & Name of the work	% of Local Content(Item wise)
N.I.T. No. NMPA/IT/LAN/2022-23/02 Dated: 21/12/2022 " Upgradation of Local Area Network at New Mangalore Port Authority Campus"	

Note : The bidder shall submit certification that the item offered meets the minimum local content and shall give details of the location(s) at which the local value addition is made as per the notification given by Department of Industrial Policy & Promotion (DIPP)

Sign & Seal of the Contractor

UNDERTAKING ON INDEMNIFICATION

We _____ (Bidders Name) hereby agrees and undertakes to indemnify, keep indemnifies, depended and hold harmless the NMPA and its Officers against all losses, penalties, costs and expenses, duties of any kind whatsoever which may arise on account of breach un-authorized act, fraud deed or any other acts of Contractor or any of its personnel. The Contractor hereby further agrees and undertakes to indemnify and keep indemnifies against any order passed by any executive, quasi-judicial or judicial authority wherein the NMPA is compelled to obey the order which arise due to breach of contract by the Contractor.

We _____(Bidders name) shall indemnify, protect and defend at its own cost, New Mangalore Port Authority and its agents & employees from & against any/all actions, claims, losses or damages arising out of;

- i. Any violation in course of its execution of the contract of any legal provisions or any right of third parties.
- ii. Failure to exercise the skill and care required for satisfactory execution of the contract.
- iii. Shall indemnify NMPA against all claims for compensation by or on behalf of any workman employed by him in connection with the contract, for injury or death by accident under the Workman Compensation Act (Act VIII of 1923) as amended from time to time.

We _____(Bidders name) shall be responsible for all commissions and omissions on part of manpower engaged for the purpose. NMPA shall not be responsible in any manner whatsoever, in matters of injury/death/health etc. of the Contractor's employees performing duties under the contract.

Sign and Seal of the Bidder/ Bidders Authorized representative

FORM OF AGREEMENT

[To be engrossed on non-judicial stamp paper of appropriate value in Karnataka issued in the name of New Mangalore Port Authority in two Sets, prior to execution by the Parties]

THIS AGREEMENT made on this theday of 2023 at Mangalore, Karnataka State in India

BY AND BETWEEN

THE NEW MANGLORE PORT AUTHORITY having its registered office and address at the Office of FA&CAO, Panambur, Mangalore – 575010, Karnataka, India, represented by *[Name & Designation of the signing authority]*, (hereinafter called the “**Authority**”, which expression shall, unless repugnant to the context or the meaning thereof, include its administrators, successors and assigns) of the One Part;

AND

..... *[name of the Contractor]*, a company incorporated under the laws of and having its registered office and address at represented by..... *[Name & Designation of the signing authority]*, (hereinafter called the “**Contractor**” which expression shall, unless repugnant to the context or the meaning thereof, include its, successors and permitted assigns) of the Other Part. Each of the “Authority” and the “Contractor” individually called a "Party" and collectively the "Parties".

RECITAL

WHEREAS:

- (A) The Authority invited Bids for Proposal Ref. _____ dated__for Upgradation of Local Area Network at New Mangalore Port Authority Campus (hereinafter called the “Works”);
- (B) After careful consideration and evaluation of the Tenders received against the said Bid document, the Authority has accepted the Bidder’s Offer Ref. __dated _____ as the same was amended or deemed to have been amended subsequently during the tender opening and evaluation, and issued **Letter of Acceptance** (of the Tender) or **LoA**, Ref. _____ ated _____ for execution and completion of the Works for the Project according to the terms & conditions of the Tender and this Contract; at the contract price specified in LoA .
- (C) The Parties now wishes to enter into this Contract for the Works on the terms and conditions of this Contract which have been fully

negotiated between the Authority and the Contractor as parties of competent capacity and equal standing.

NOW, THEREFORE, IN CONSIDERATION OF MUTUAL PROMISES, COVENANTS AND AGREEMENTS CONTAINED HEREIN AND FOR GOOD AND VALID CONSIDERATION, THE ADEQUACY OF WHICH HAS BEEN ACKNOWLEDGED BY THE PARTIES, THE PARTIES, INTENDING TO BE LEGALLY BOUND, HEREBY AGREE AS FOLLOWS

- 1) In this Agreement words and expressions shall have the same meanings as are respectively assigned to them in the General Conditions of Contract hereinafter referred to.
- 2) In consideration of the payments to be made by the Authority to the Contractor under the Contract, the Contractor shall carry out and complete the Upgradation of Local Area Network at New Mangalore Port Authority Campus work and discharge all the relevant obligations on its part specified in, or to be inferred from, and in all respects in accordance with this Agreement.
- 3) **Contract Documents:**
 - 3.1) The following documents shall be deemed to form and be read and construed as part of this Agreement viz.:
 - a) Letter of Acceptance (“LoA”) Ref. _____ dated _____
 - b) “Schedule of Prices” and” Schedule of payments on Milestone Completion” as submitted by Bidder.
 - c) Bid Documents in its entirety including all Addendum, Corrigendum and Clarifications duly signed and submitted by the Bidder.
 - d) All communications exchanged between Authority and Contractor during tender process till issue of LoA.
 - 3.2) The Contractor hereby declares to have full knowledge and understanding of the contents of all the foregoing documents whether contained in or incorporated by reference therein and accepts all the terms and conditions contained therein. In the event of any ambiguity or conflict between any of the foregoing Contract Documents, or any of the terms & conditions contained therein, the Contractor shall, prior to commencement of the Works, be deemed to have obtained from the Authority or Authority’s Engineer, as the case may be, all necessary clarifications in order to get such ambiguity or conflicts resolved satisfactorily. The order of precedence of the foregoing documents shall be the same as listed herein above.
- 4) **Scope of Work, Price Schedule, Milestone Completion & Payment**
 - 4.1) The Contractor shall carry out and complete the Scope of Work as detailed in the bid document
 - 4.2) The Contractor hereby warrants and undertakes that the Works shall be executed according to the applicable Codes, quality

standards and statutory requirements to the complete satisfaction of Authority and the Authority's Engineer and when completed shall be fit for the purpose set out in the Contract Documents.

4.3) In consideration of full and complete discharge of the Contractor's obligations under this Contract, the Authority shall pay to the Contractor Contract Price denominated in Indian Rupees as set out in the Schedule of Prices and Schedule of payments on Milestone Completion".

4.4) Any failure by the Contractor to complete or cause to be completed the whole of the Works within the Contract Completion Date including the respectively identified Milestones as per **Milestone Completion & Payment Schedule** or any permitted extensions hereto for any of them for reasons attributable to the Contractor as may be determined by the Authority and the Authority's Engineer, will entail payment by way of Liquidated Damages for Delay by the Contractor to the Authority as set out in the Contract.

5) **Notices**

5.1) Any notice to be given under the Contract shall be sent to the Authority or the Contractor, as the case may be, at the address set forth below:

Authority Contractor: NEW MANGALORE PORT AUTHORITY

Address:

Office of FA&CAO

New Mangalore Port Authority

Panambur, Mangalore – 575010

Attn.: Attn.:

Title: Title:

Tel. Tel.

Fax: Fax:

E-mail:

5.2) Any notice to be given hereunder by one Party to the other Party may be sent by pre- paid registered post or by overnight courier or by facsimile or by e-mail to its address given herein above or to such other address as may have been communicated by such Party to the other Party and such notice shall be deemed to have been received if sent by pre-paid registered post or overnight courier on the date of its delivery as evidenced by the postal mark or receipted courier advice; if sent by facsimile on the date of its

transmission stamped on it; and if sent by e-mail on the date of its transmission as evidenced by its properties.

6) General

- 6.1) This Agreement shall be deemed to have been effective from the date of issue of Letter of Acceptance (of the Tender) to the Bidder by the Authority. The Milestone Schedule for completion of the Works shall be deemed to have commenced from Appointed Date. This Agreement which shall remain valid until all the obligations under this Agreement is satisfactorily discharged by the Parties hereto. However, all those provisions of the Agreement which are deemed to continue even after expiry of such validity shall continue to be in full force and effect as expressly provided in the Agreement.
- 6.2) This Contract supersedes all prior negotiations, representations, warranties and agreements related hereto whether oral or written.
- 6.3) No amendments to this Agreement shall be effective, unless the same is evidenced in writing and duly signed by the authorized representatives respectively of the Authority and the Contractor.
- 6.4) This Agreement is executed in counter-parts, each of which shall be deemed to be original and retained by each of the Parties but together they shall constitute one and the same Agreement.

IN WITNESS WHEREOF the Authority and the Contractor have caused this Agreement to be duly executed by their duly authorized representatives as of the day, month and year herein above written.

for & on behalf of Authority
NEW MANGALORE PORT AUTHORITY
.....

for & on behalf of Contractor
.....

Signature.....
Name:.....
Designation:.....

Signature.....
Name:.....
Designation:.....

In the presence of:

In the presence of:

Signature:.....
Name :.....
Designation:.....
Address:.....

Signature:.....
Name :.....
Designation:.....
Address:.....

(on behalf of the Authority)

(on behalf of the Contractor)

ANNEXURE -XVI

FORMAT OF PERFORMANCE SECURITY DEPOSIT BANK GUARANTEE

In consideration of the Board of Authorities of the New Mangalore Port incorporated by the Major Port authority's Act, 1963 as amended by the Major Port Authority Amendment Act, 1974 (hereinafter called "The Board") which expression shall unless excluded by or repugnant to the context or meaning thereof be deemed to include its successors and assigns has awarded the Contract for Upgradation of Local Area Network at New Mangalore Port Authority Campus vide Work Order No. _____ (hereinafter called 'the Contract') to M/s. **"Name of the Contractor"** (hereinafter called the 'Contractor') which expression shall unless excluded by or repugnant to the context or meaning thereof be deemed to include his heirs, executives, administrators, successors and permitted assigns under the terms and conditions of the Contract, made between the Contractors and the Board, the Contractor is bound to submit a performance Guarantee of `----- /-(Rupees-----) to Board, we the Corporation Bank, full address of the bank to be mentioned (hereinafter referred to as 'the Bank') at the request of the Contractors do hereby undertake to pay to the Board an amount not exceeding ` _____ /-(Rupees _____) against any loss or damage caused to or suffered or which would be caused to or suffered by the Board by reason of any breach by the Contractors of any of the terms and conditions of the said Contract.

1. We, _____ (Name of the Bank), do hereby undertake to pay ` _____ /- (Rupees _____) as the amounts due and payable under this guarantee without any demur, merely on a demand from the Board stating that the amount claimed is due by way of loss or damage caused to or which would be caused to or suffered by the Board by reason of the Contractor's failure to perform the said Contract. Any such demand made on the Bank shall be conclusive as regards the amount due and payable by the Bank under this Guarantee. However, our liability under this Guarantee shall be

restricted to an amount not exceeding `_____/-(Rupees _____).

2. We, _____(Name of the Bank), undertake to pay to the Board any money so demanded notwithstanding any dispute or disputes raised by the Contractor in any suit or proceeding before any court or Tribunal relating thereto, our liability under this present being absolute and unequivocal. The payment so made by us under this bond shall be a valid discharge of our liability for payment there under and the Contractor shall have no claim against us for making such payment.
3. We, _____(Name of the Bank), further agree with the Board that the guarantee herein contained shall remain in full force and effect during the period that would be taken for the performance of the said Contract and it shall continue to be enforceable till all the dues of the Board under or by virtue of the said Contract have been fully paid and its claims satisfied or discharged or till the FA&CAO of the said Board certified that the terms and conditions of the said Contract have been fully and properly carried out by the said Contractors and accordingly discharge this guarantee. Unless the demand or claim under this guarantee is made on us in writing on or before _____, we shall be discharged from all liabilities under this guarantee thereafter. This Guarantee will remain in force from the date hereof, i.e. till _____ and unless a demand or suit or action to enforce any claim under the guarantee is made within three months from the date of expiry of this guarantee, i.e. on or before _____, all your rights under this guarantee shall be forfeited and we shall be relieved and discharged from all liabilities under this guarantee thereafter PROVIDED, that the Bank shall at the request of the Board but at the cost of the Contractors, renew or extend this guarantee for such further period or periods as the Board may require from time to time.
4. We, _____(Name of the Bank), further agree with the Board that the Board shall have the fullest liberty without our consent and without affecting in any manner our obligations hereunder to vary any of the terms and conditions of the said Contract or to extend the time of performance by the said Contractors from time to time to postpone from any time or from

time to time any of the powers exercisable by the Board against the said Contractors and to forebear or enforce any of the terms and conditions relating to the said Contract and we shall not be relieved from our liability by reason of any such variation or extension being granted to the Contractors or for any forbearance, act or omission on the part of the Board or any indulgence shown by the Board to the Contractors or by any such matter or thing whatsoever which under the law relating to sureties would but for this provision, have effect of so relieving us.

5. This Guarantee will remain valid for the entire period as agreed, even though there happens to be change in the constitution of the bank or that of the Contractor.
6. We, _____ (Name of the Bank), lastly undertake not to revoke this guarantee during its currency except with the previous consent of the Board in writing.
7. Our liability under this Guarantee shall not exceed `_____/-(Rupees_____).
8. This Guarantee shall valid up to _____.
9. We, are liable to pay the guaranteed amount or any part thereof under this guarantee only & only if you serve us a written claim or demand on or before ----/-----/2023.
10. The Bank Guarantee is encasheable at our _____ branch at Mangalore, Karnataka

Dated ----- day of -----2023

For

(Authorized Signatory/s)

(Name & Code No.)

(For and on behalf of Bank.)

Sign & Seal of the Contractor

UNDERTAKING ON NON-BLACKLISTING

To

The FA & CAO,
New Mangalore Port Authority,
Panambur, Mangalore -575010

Dear Sir,

In response to the tender No. _____ Dated _____ for "< >", I/ We hereby declare that presently our Company/ Firm _____ is having unblemished record and is not declared ineligible for corrupt & fraudulent practices either indefinitely or for a particular period of time by any Departments of Central Government /Central PSE/Autonomous Bodies under the Central Government. We further declare that presently our Company/ firm _____ is not blacklisted and not declared ineligible for reasons of corrupt & fraudulent practices by any State/Central Government/ PSU/ Autonomous Body on the date of Bid Submission. If this declaration is found to be incorrect then without prejudice to any other action that may be taken, my/ our security may be forfeited in full and the tender if any to the extent accepted may be cancelled.

Thanking you,

Yours faithfully

(Signature of the Authorized signatory of the Bidding Organization)

Name:

Designation:

Date:

Company Seal:

UNDERTAKING CHANGES/MODIFICATIONS

To

The FA & CAO,
New Mangalore Port Authority,
Panambur, Mangalore -575010

Dear Sir,

We.....
.....
.....do hereby confirm that no changes have been made in the tender document downloaded and submitted by us for the Tender No.....Dated.....

Yours faithfully,

Signature :

Name & Designation :

DECLARATION ON IPR/PATENT RIGHTS

(To be submitted on the Letterhead of the Bidder)

(Place) (Date)

To

The FA & CAO,
New Mangalore Port Authority,
Panambur, Mangalore -575010

Sir,

Sub: Undertaking on intellectual property rights for the software/hardware Upgradation and support services Project at NMPT

I/We do hereby undertake that none of the deliverables being provided by us is infringing on any intellectual and industrial property rights as per the applicable laws of relevant jurisdictions having requisite competence.

I/We also confirm that there shall be no infringement of any intellectual and industrial property rights as per the applicable laws of relevant jurisdictions having requisite competence, in respect services/tools or any part thereof to be supplied by us. We shall indemnify NMPA against all cost/claims/legal claims/liabilities arising from third party claim in this regard at any time on account of the infringement or unauthorized use of any intellectual and industrial property rights of any such parties, whether such claims arise in respect of manufacture or use. Without prejudice to the aforesaid indemnity, we shall be responsible for the completion of the delivery of the Project at NMPT irrespective of the fact of claims of infringement of any or all the rights mentioned above.

If at a later date it is found that it does infringe on any intellectual and industrial property rights, I/We absolve and indemnify NMPA of any legal action.

Yours faithfully,

Authorized Signatory
Designation

CONFLICT OF INTEREST

(Company letter head)

[Date]

To

The FA & CAO,
New Mangalore Port Authority,
Panambur, Mangalore -575010
Sir,

Sub: Undertaking on Conflict of Interest

I/We, as the Implementation Agency, do hereby undertake that there is absence of, actual or potential conflict of interest on our part as the bidder or any prospective subcontractor due to prior, current, or proposed contracts, engagements, or affiliations with NMPT.

I/We also confirm that there are no potential elements (time-frame for service delivery, resource, financial or other) that would adversely impact our ability to complete the requirements as given in the RFP.

We undertake and agree to indemnify and hold NMPA harmless during the term of the contract or five years thereafter against all claims, losses, damages, costs, expenses, proceeding fees of legal advisors (on a reimbursement basis) and fees of other professionals incurred (in the case of legal fees and fees of professionals, reasonably) by NMPT and/or its representatives, if any such conflict arises later.

Yours faithfully,

Authorized Signatory
Designation
Company Seal

NON-DISCLOSURE AGREEMENT

Format for Non-Disclosure Agreement

This Non-Disclosure Agreement dated the day of _____, 2023

BETWEEN

New Mangalore Port Authority, Panambur, Mangalore 575010 (hereinafter referred to as the “**Disclosing Party**”)

AND

_____, a company incorporated under the laws of India and having its registered office at _____ (hereinafter referred to as “**Receiving Party**”) (collectively referred to as “**the parties**”)

WHEREAS

In connection with “_____”, the Receiving Party as

Contractor by the Disclosing Party, the Parties have agreed to execute this Nondisclosure

Agreement to ensure that all information provided by the Disclosing Party to the Receiving

Party in the course of engagement of the Receiving Party as **Contractor** is kept confidential

NOW IT IS HEREBY AGREED AS FOLLOWS:

13.1.1 Definitions:

- a) “**Purpose**” shall mean “_____”, by the Receiving Party to the Disclosing Party.
- b) “**Confidential Information**” shall mean all discussions, documents, paper, discs, technology, procedure and other information of a confidential nature pertaining to, generated or disclosed by either

party in any form including in writing, electronically, computerized orally or otherwise marked as

“Confidential” or informed to be „Confidential“ or relating to the Purpose, including, without limitation:

(i) All financial details investment plans, price specifications, schemes, technology know-how, techniques and information relating to business, investments, transactions or affairs, services being rendered, plans for business investments or for improving services and discussions on future services; and all other information, material or data relating to the current and /or future business and operations of the Disclosing Party and analysis, compilations, studies, summaries, extracts or other documentation prepared by the Receiving Party arising out of the Confidential Information.

(ii) The terms of this or any other agreement or document signed or to be signed by or between the Parties and the provisions thereof.

However, “Confidential Information” shall exclude any part of such disclosed information or data which: -

i. is in or comes into the public domain in any way without breach of this Agreement by the Receiving Party; or

ii. the Receiving Party can show (a) was in its possession or known to it by being in its use or being recorded in its files or computers or other recording media prior to receipt from the Disclosing Party and was not previously acquired by the Receiving Party from the Disclosing Party under an obligation of confidence, or (b) to have been developed by or for the Receiving Party at any time independently of any information disclosed to it by the Disclosing Party; or

(iii) the Receiving Party obtains from a source other than the Disclosing Party without breach by the Receiving Party or such source or any obligation of confidentiality or non-use towards the Disclosing Party; or

- (iv) is hereafter furnished by the Disclosing Party to a third party without restriction on disclosure or use; or
- (v) is disclosed by the Receiving Party (a) with the prior written approval of the Disclosing Party, or (b) without such approval, after a period of one (1) year from the date of receipt thereof.

The Receiving Party shall maintain the Disclosing Party's Confidential Information in confidence and shall exercise in relation thereto no lesser security measures and degree of care than those which the Receiving Party applies to its own Confidential Information which the Receiving Party warrants as providing adequate protection against unauthorized disclosure, copying or use. The Receiving Party shall ensure that disclosure of such confidential information is restricted to those employees, directors, officers, representatives, advisors, consultants or agents (collectively referred to as "**Representatives**") of the Receiving Party having the need to know the same for the Purpose. Copies or reproductions shall not be made except to the extent reasonably necessary for the Purpose and all copies made shall be the property of the Disclosing party. All Confidential Information and copies thereof shall be returned to the Disclosing Party within seven (7) days of receipt of a written request from the Disclosing Party.

The Receiving Party shall not attempt to reverse engineer, decompile, disassemble or reverse translate any Confidential Information provided by the Disclosing Party or discover the source code or trade secrets in any such Confidential Information.

Nothing in this Agreement shall limit the ability of a party to disclose such Confidential Information of the other party if such disclosure is

- (a) required to be made pursuant to any law or regulation, government authority, duly authorized subpoena or court order, whereupon that party shall provide prompt notice to the Disclosing Party of the Confidential Information in question, who will thereof have the opportunity to respond prior to such disclosure;
- (b) Required to be made by a court or other tribunal in connection with the enforcement of such Disclosing and all copies made shall be

properties of disclosing party. All Confidential Information and copies thereof shall be returned to the Disclosing Party within seven (7) days of receipt of a written request from the Disclosing Party. The Receiving Party shall not attempt to reverse engineer, decompile, disassemble or reverse translate any confidential information provided by the Disclosing Party or discover the source code or trade secrets in any such Confidential Information.

Nothing in this Agreement shall limit the ability of a party to disclose such Confidential Information of the other party if such disclosure is

- (a) Required to be made pursuant to any law or regulation, government authority, duly authorized subpoena or court order, whereupon that party shall provide prompt notice to the Disclosing Party of the Confidential Information in question, who will thereof have the opportunity to respond prior to such disclosure;
- (b) Required to be made by a court or other tribunal in connection with the enforcement of such Disclosing Party's rights under this Agreement, or
- (c) Is approved by the prior written consent of the Disclosing Party of the Confidential Information.

13.2 Limitations and Warranty :

- a) The Receiving Party shall (i) not divulge the Disclosing Party's Confidential Information, in whole or in part, to any third party without the prior written consent of the Disclosing Party, (ii) use the same only for the Purpose, and (iii) make no commercial of the same or any part thereof without the prior written consent of the Disclosing Party. Notwithstanding the foregoing, the Receiving Party shall be entitled to make any disclosure required by law of the Disclosing Party's Confidential Information.
- b) The Disclosing Party warrants its right to disclose its Confidential Information to the Receiving Party and to authorize the Receiving Party to use the same for the Purpose.

13.3 Disclaimer: All rights in Confidential Information are reserved by the Disclosing Party and no rights or obligations other than those

expressly recited herein are granted or to be implied from this Agreement. In particular, no licence is hereby granted directly or indirectly under any invention, discovery, patent, copyright or other intellectual property right now or in the future held, made, obtained or licensable by either party. Nothing in this Agreement or its operation no rights or obligations other than those expressly recited herein are granted or shall constitute an obligation on either party to enter into the aforesaid business relationship or shall preclude, impair or restrict either party from continuing to engage in its business otherwise that in breach of the terms of this Agreement

13.4 **Notices** :All notices under this Agreement shall be in writing, sent by facsimile or first- class registered or recorded delivery post to the party being served at its address specified above or at such other address of which such party shall have given notice as aforesaid, and marked for the attention of that party's signatory of this Agreement. The date of service shall be deemed to be the day following the day on which the notice was transmitted or posted as the case may be.

13.5 **No Bar on Participation in Projects initiated by the Disclosing Party**: The Disclosing Party acknowledges that the advisory mandate awarded to the Receiving Part will not bar the Receiving Party or any of its group companies from bidding or participating in any projects initiated by the Disclosing Party on the ground that the Receiving Party was privy to information which was not within the public domain. On its part the Receiving Party shall ensure, confirm and warrant that neither the Receiving Party nor any of its group companies will misuse the information available to it in the course of the advisory mandate to derive an unfavourable advantage in bidding /participation in any projects initiated by the Disclosing Party .The Disclosing Party on its part shall not summarily debar or reject the bid/participation of the Receiving Party on the ground that the Receiving Party was Privy to confidential information and it has derived undue advantage, unless reasonable opportunity it's given to the Receiving Party to put forth its say.

13.6 **Non-Assignment**:

This Agreement is personal to the parties and shall not be assigned or otherwise transferred in whole or in part by either party without the prior written consent of the other party.

13.7 Forbearance:

No relaxation, forbearance or delay by a party in enforcing any of the terms of this Agreement shall prejudice, affect or restrict its rights, nor shall waiver by a party of any breach hereof operate as a waiver of any subsequent or continuing breach.

13.8 Indemnity:

The Receiving Party agrees to indemnify the Disclosing Party for any loss or damage suffered due to any breach by it of its obligations under this Agreement.

Damages shall include all costs, expenses and attorney's fees incurred by the Disclosing Party in the enforcement of this Agreement.

provided always that in no event shall either party be liable to the other party for any indirect, incidental and/or consequential damages, lost business, lost savings or lost profits or revenues resulting from a breach of this agreement even if the breaching party has been advised of the possibility of the occurrence of such damages.

13.9 Non-Publicity :

The parties shall not make any announcement or disclosure of any kind whatsoever concerning this Agreement, including without limitation the existence of this Agreement, without the other Party's prior written consent whatsoever concerning this Agreement, including without limitation the existence of this Agreement, without the other Party's prior written consent unless such announcement and/or disclosure is required by law.

13.10 Notwithstanding anything contained herein to the contrary, the obligations of the Parties herein shall continue for a period of one (1) year from the date of this Agreement or if a further agreement is entered into, the termination of such further agreement, whichever is the later.

13.11 The Receiving Party agrees that the obligations contained in this Agreement shall extend to the affiliated companies of the Receiving Party and to all its advisors and consultants. In this respect the

Receiving Party represents that agreement to keep such information confidential, on terms similar to this Agreement, is in place before disclosing any Confidential Information to such affiliate, advisor or consultant.

13.12 **Entire Agreement** :

This Agreement constitutes the entire agreement and understanding between the parties in respect of Confidential Information and supersedes all previous agreements, understandings and undertakings in such respect. This Agreement cannot be amended except by written agreement signed on behalf of each party by their authorized signatories.

13.13 **Dispute Resolution** :

The parties shall attempt to resolve any dispute arising out of or in connection with this Agreement by mutual consultation, failing which such dispute shall be referred to and finally resolved by arbitration in India under the auspices and governed by the provisions of the Arbitration and Conciliation Act, 1996. The arbitration shall be at NMPA and only the courts at NMPA shall have the jurisdiction to try any matters arising from the arbitration. The language of the arbitration shall be in English.

13.14 **Governing Law and Jurisdiction**: This Agreement shall be governed by and constructed in all respects in accordance with the laws of India.

IN WITNESS WHEREOF, the parties have caused this Agreement to be executed by their duly authorized representatives on the day and year first above written

On behalf of **Disclosing Party** On behalf of Receiving Party

Signature _____ Signature _____

Name _____ Name _____

Title _____ Title _____

OEM/MAF AUTHORIZATION

Original Manufacturer's Authorization Form

(Please submit for all the hardware and software OEMs)

(To be submitted on the Company Letter head of the OEM)

Date:

To

The FA & CAO,

New Mangalore Port Authority,

Panambur, Mangalore -575010

**Sub: Authorization of <company name of Bidder> to Provide Services
Based on Our Product(s)**

Sir,

WHEREAS _____ who are official producers of (write name of Products)_____ and having production facilities at _____ do hereby authorize _____ located at _____ (hereinafter, the "Bidder") to submit a bid and subsequently negotiate and sign a Contract with you for resale of the following Products produced by us, for the quantities, specifications and delivery schedule called for by the Supply Requirements associated with the above Invitation for Bids:

We hereby extend to you a full guarantee and warranty in accordance with the Contract and with our own standard product warranty, and duly authorize the Bidder to act on our behalf in fulfilling all warranty obligations with respect to the below-listed products offered for resale by the Bidder in relation to this Invitation for Bids. We here by confirm that the items proposed by bidder are adequate to fulfill the solution requirements of NMPT.

We certify that the version of the Software/Hardware will be supported till the end of Post warranty CMC Support period of the contract. We also certify that the Bidder is qualified by us to provide the maintenance, technical or help desk

support, new version upgrade and/or other services related to the above-listed Products

In the capacity of

Signed Duly authorized to sign the authorization for and on behalf of :

_____ Dated on _____ day of _____, _____.

Yours faithfully,

Authorized Signatory

Designation

OEM's company name

CC: Bidder's corporate name & Address

Note: This letter of authority must be on the letterhead of the Producer, must be signed by a person competent and having the power of attorney to bind the Producer, and must be included by the Bidder in its bid.

Indicative Bill of Quantity

Sl. No.	Item Description	Item Code	Quantity	Units
1	2	3	4	5
1	Core Switch 40 G Back bone(Specification: Refer Technical Sheet)			
1.01	Hardware & Interface Requirements	item1	2.00	Nos
1.02	Internal Redundant Power Supplies and Fans	item2	8.00	Nos
1.03	Power Cables	item3	8.00	Nos
1.04	Modules(12p 40G/100G QSFP28 Module)	item4	4.00	Nos
1.05	Modules(48p 10G/25G SFP28 Module)	item5	2.00	Nos
1.06	Cable(40G QSFP+ to QSFP+ 3m DAC Cable)	item6	2.00	Nos
1.07	Cable(10G SFP+ to SFP+ 3m DAC Cable)	item7	1.00	Nos
1.08	Warranty - 24X7 WITH 6 CTR (switch should be provided with hardware replacement warranty and ongoing software upgrades for all major and minor releases for a period of Total 3 years.)	item8	2.00	Nos
1.09	Additional Support / Warranty(Additional 4 years warranty / AMC support pack)	item9	2.00	Nos
2	Distribution Switch 40G & 10 G Support(Specification: Refer Technical Sheet)			
2.01	Hardware & Interface Requirements	item10	5.00	Nos
2.02	40G QSFP+ to QSFP+ 3m DAC Cable	item11	5.00	Nos
2.03	10G SFP+ to SFP+ 3m DAC Cable	item12	5.00	Nos

2.04	Warranty - 24X7 WITH 6 CTR	item13	5.00	Nos
2.05	Additional 4 years warranty / AMC support pack	item14	5.00	Nos
3	24 Port Edge Switch(10 G Support)(Specification Refer Technical Sheet)			
3.01	Hardware & Interface Requirements	item15	30.00	Nos
3.02	Additional 4 years warranty / AMC support pack	item16	30.00	Nos
3.03	Warranty - 24X7	item17	30.00	Nos
4	48 Port Edge Switch(10 G Support) (Specification Refer Technical Sheet)			
4.01	Hardware & Interface Requirements	item18	12.00	Nos
4.02	Warranty - 24X7	item19	12.00	Nos
4.03	Additional 4 years warranty / AMC support pack	item20	12.00	Nos
5	<i>Transceivers</i>			
5.01	10G SFP+ transceiver, LC LR 10km SMF	item21	94.00	Nos
5.02	40G QSFP+ LC LR4 SM Transceiver	item22	6.00	Nos
6	On-Prem NAC with minimum 100 user perpetual license from day 1			
6.01	Secure Network Access Control Hardware/VM	item23	3.00	Nos
6.02	Warranty - 24x7	item24	3.00	Nos
6.03	Additional 4 years warranty / AMC support pack	item25	3.00	Nos
7	<i>NAC VM License</i>			
7.01	Perpetual license	item26	1.00	Nos
7.02	Warranty – 24x7	item27	1.00	Nos
7.03	Additional 4 years warranty / AMC support pack	item28	1.00	Nos
8	<i>NMS</i>			

8.01	Multivendor, on-premises campus network management System for wired Network	item29	1.00	Nos
8.02	Warranty – 24x7 (NMS should be provided with software upgrades for all major and minor releases for a period of Total 3 years.)	item30	1.00	Nos
8.03	Warranty-24x7(Day One Device License which has to be proposed)	item31	40.00	Nos
8.04	Additional 4 years warranty / AMC support pack	item32	1.00	Nos
8.05	50" TV	item32A	1.00	Nos
9	<i>Point to Point Wi-Fi Connection</i>			
9.01	P2P (Wi-Fi 6 P2P Access Point - Bridge Mode)	item33	6.00	Nos
9.02	POE Adapter	item34	6.00	Nos
9.03	Mounting Pole and Bracket	item35	6.00	Nos
10	<i>Spare Stock</i>			
10.01	48 port Edge Switch	item36	1.00	Nos
10.02	24 port Edge Switch	item37	2.00	Nos
10.03	SFP Module(10G SFP+ transceiver, LC LR 10km SMF)	item38	4.00	Nos
11	<i>Supply, Installation, Testing and Commission(Active Network)</i>			
11.01	Supply, Transportation, Shipment, etc...	item39	1.00	Nos
11.02	Installation, Testing & Commission	item40	1.00	Nos
11.03	Training with 3 months onsite support post go-live	item41	1.00	Nos
11.04	36months DLP	item42	1.00	Nos
12	<i>Passive Network</i>			
12.01	Fiber Optic Cable, 12cores-fiber, OS2, loose tube, dry - Outdoor, armoured OFC with LSZH. Single mode, FRP, single drum and Single OEM	item43	5000.00	Mt.
12.02	LIU(12F, 1U, LC SM OS2 , Loaded with Pigtails, Splice tray, adapter & splice protectors)	item44	30.00	Nos

12.03	LIU(24F, 1U, LC SM OS2 , Loaded with Pigtails, Splice tray, adapter & splice protectors)	item45	4.00	Nos
12.04	Fiber Patch Cord - Single mode 3mtr length	item46	60.00	Nos
12.05	Patch Panel - Cat 6, 24-port Loaded Modular Straight Jack Panel with labels, clear label covers and rear cable support bar, Height, 1U	item47	27.00	Nos
12.06	Category 6 U/UTP Cable, low smoke zero halogen, gray jacket, 4 pair count, 1000 ft (305 m) length	item48	60.00	Nos
12.07	PVC Conduit 30mm	item49	300.00	Mt.
12.08	HDP Conduit 1"	item50	4600.00	Mt.
12.09	Case & Capping Patti 1.5"	item51	4500.00	Mt.
12.1	Case & Capping Patti 1"	item52	1000.00	Mt.
12.11	GI Pipe	item53	160.00	Mt.
12.12	27U Network Rack	item54	17.00	Nos
12.13	CAT6 Single I/O Face Plate	item55	425.00	Nos
12.14	CAT6 Single I/O Face Plate Back Box	item56	425.00	Nos
12.15	2Mtr CAT6 UTP Patch Cords	item57	425.00	Nos
13	<i>Supply, Installation, Testing and Commission(Passive Network)</i>			
13.01	Supply, Transportation, Shipment, etc...	Item58	1.00	Nos
13.02	Passive cable laying work	Item59	1.00	Nos
13.03	Passive cable termination	Item60	1.00	Nos
13.04	OTDR testing on full network	Item61	1.00	Nos
13.05	Penta testing on full network	Item62	1.00	Nos
14	<i>Active Directory - AD</i>			
14.01	Windows Server 2022 or latest, down gradable to lower versions.	item63	4.00	Nos
14.02	Windows Client Access License	item64	400.00	Nos

14.03	Server - Primary Domain, Secondary Domain, DNS Server	item65	4.00	Nos
14.04	Server (Warranty - 24X7 WITH 6 CTR)	item66	4.00	Nos
14.05	Server - Additional 4 years warranty / AMC support pack	item67	4.00	Nos
15	Data Storage			
15.01	Storage - 25 TB raw, 16 TB useable, expandable to 31.5 TB useable, Gb Ethernet 4 ports standard, 10GbE SFP, 10GbE,	item68	2.00	Nos
15.02	DLP and Antivirus for Storage Vault	item69	2.00	Nos
16	UPS			
16.01	15 KVA ON LINE UPS	item71	1.00	Nos
16.02	1 KVA ON LINE UPS	item72	20.00	Nos
16.03	2kVA ON LINE UPS	item73	3.00	Nos
17	Supply, Installation, Testing and Commission(AD &UPS)			
17.01	Supply, Transportation, Shipment, etc...	item74	1.00	Nos
17.02	Installation, Testing & Commission	item75	1.00	Nos
17.03	Training with 3 months onsite support post go-live	item76	1.00	Nos
17.04	36months DLP	item77	1.00	Nos
18	Civil Work By SI (Establishing the connectivity through OFC&UTP)			
18.01	Road Cutting, Laying, Redoing Road etc...	item78	100.00	Mt.
18.02	Digging	item79	2000.00	Mt.
18.03	Saddling	item80	250.00	Nos
18.04	HDPE Laying	item81	1900.00	Mt.
18.05	OFC Laying	item82	2000.00	Mt.

18.06	OFC Termination	item83	40.00	Mt.
18.07	OFC Marking (Concrete 1X3)	item84	25.00	Nos
18.08	casing capping / PVC laying	item85	5000.00	Mt.
18.09	UTP laying	item86	14000.00	Mt.
18.1	I/O termination	item87	850.00	Nos
19	<i>On Site Support -7 Years Contract</i>			
19.01	Network Administrator - 7 years (Qualification and Exp: BE Computer / IS / Electronics & Communication, CCNA / CompTAI Network / Aruba Network Certified, 4 years of campus grade network experience managing around 200+ nodes <u>OR</u> any other education degree with minimum 8 years of experience ,managing 200+ nodes, CCNA / CompTAI Network / Aruba Network Certified)	item88	1.00	Nos
19.02	Network Support Engineer (Stay in the port premise) - 7 years(Qualification& Exp: BE Computer / IS / Electronics & Communication, CCNA / CompTAI Network / Aruba Network Certified, 2 years of campus grade network experience managing around 200+ nodes <u>OR</u> any other education degree minimum 4 years of experience, managing 200+ nodes, CCNA / CompTAI Network / Aruba Network Certified)	item89	1.00	Nos

Note: OEMs of the Hardware/Software quoted should provide technical support throughout the contract period mentioned in the RFP. The OEM certification stating that Hardware/Software quoted shall be supported throughout the contract period shall be submitted along with the technical bid by the bidder all the items.

NMPA BANK DETAILS

Name of the Payee:

The FA & CAO, NMPA, Panambur, Mangalore for remitting Tender fee through NEFT / RTGS.

1	Name of the bank	State Bank of India, Panambur, Mangalore -575 010
2	Bank Account No.	10205649448
3	IFSC Code.	SBIN0002249
4	MICR Code.	575002011

CHECK LIST

PART - V

SCHEDULE FOR CHECKLIST OF DOCUMENTS TO BE UPLOADED ALONG WITH TECHNO-COMMERCIAL

DETAILS OF DOCUMENT TO BE SUBMITTED			YES	NO
TECHNICAL BID	1	RTGS/NEFT transaction details towards Cost of Tender& EMD or supporting document for exemption as per clause 1.1(k).		
	2	Duly Signed & sealed copy of tender document (all pages – Self attested)		
	3	Supporting documentary evidence of work orders and satisfactory completion certificate issued by the client duly self-attested and TDS certificate of the supporting work. Copy of TDS certificate of the supporting work should also be uploaded. (Work completion Certificate must contains W.o. No., Date, Completion Date and Amount paid), as per Annexure -IV		
	4	Copies of Annual turnover, profit and loss Account statements, balance sheet and Auditor’s report for the last three years, endorsed by Chartered Accountant with attestation.		
	5	Certificates: a) GST Registration Certificate. b) Pan card copy c) Employees State Insurance Registration certificate d) PF Registration Certificate. e. ISO 9001 27001 Certificate		
	6	a) Annexure – I – Letter Comprising the Tender. b) Annexure – II – Proforma of irrevocable Bank Guarantee Towards Bid Bond. c) Annexure – III – Particulars of Bidder. d) Annexure – IV – Pre-Qualification of Bidders. e) Annexure – V – Financial Turnover. f) Annexure – VI – Statement of Legal Capacity. g) Annexure – VII – Bank Details of the Bidder for E-Payment. h) Annexure –VIII –Power of Attorney for signing the		

		<p>Tender.</p> <p>i) Annexure – IX – Power of Attorney for Lead Member of Joint Venture.</p> <p>j) Annexure –X – Joint Bid Agreement.</p> <p>k) Annexure –XI – Pre Contract Integrity Pact.</p> <p>l) Annexure –XII- Details of ongoing contract at NMPA</p> <p>m)Annexure-XIII – Verification of Local Content</p> <p>n) Annexure-XIV – Undertaking on Indemnification</p> <p>o) Annexure–XV – Form of Agreement</p> <p>p) Annexure –XVI – Performance Bank Guarantee</p> <p>q) Annexure –XVII – Undertaking on non-blacklisting Declaration on IPR/Patent rights</p> <p>r) Annexure –XVIII – Undertaking changes/modifications</p> <p>s) Annexure –XIX –Non-Disclosure agreement</p> <p>t. Annexure –XX Conflict of interest</p> <p>u) Annexure–XXI Non- Disclosure agreement</p> <p>v) Annexure – XXII OEM Declarations</p>		
	7	Power of Attorney in original as per Tender.		
PRICE BID	PART-III - Price Schedule (Online Mode Only)			